

Energy Efficiency and Rebound Effects in the United States
Implications for Renewables Investment and Emissions Abatement

Submitted in partial fulfillment of the requirements for

the degree of

Doctor of Philosophy

in

Engineering & Public Policy

Brinda Ann Thomas

B.S. Physics, Stanford University

Carnegie Mellon University
Pittsburgh, PA

December 2012

©Copyright, 2012, Brinda Thomas. All rights reserved.
This work is licensed under the Creative Commons Attribution-Noncommercial-No
Derivative Works 3.0 Unported License. To view a copy of this license, visit
<http://creativecommons.org/licenses/by-nc-nd/3.0/> or send a letter to Creative Commons,
171 Second Street, Suite 300, San Francisco, California, 94105, US

Acknowledgements

This work was supported in part by a National Science Foundation (NSF) Graduate Research Fellowship, the Gordon Moore Foundation, the Carnegie Mellon Electricity Industry Center (CEIC), the Climate Decision-making Center (CDMC) (SES-0345798), which was formed through a cooperative agreement between the NSF and Carnegie Mellon University (CMU), and the Climate and Energy Decision Making Center (CEDM) (SES-0949710), also through a cooperative agreement between the NSF and CMU. The views expressed do not necessarily reflect the views of these organizations and all errors are my own.

This dissertation would not have been possible without the guidance and support of many individuals who have shaped my graduate school experience at Carnegie Mellon's Engineering and Public Policy (EPP) department. My advisor and thesis committee chair, Ines Azevedo, has been an incredible mentor and teacher, asking insightful questions, challenging my assumptions, and empowering me to grow as a scholar. I am grateful for M. Granger Morgan's guidance on my energy efficiency research and for helping me to better understand and communicate the policy implications of my research. The time and invaluable feedback from thesis committee members, H. Scott Matthews and Karen Turner, have also helped me to strengthen the empirical analysis and sharpen the interpretation of results in my dissertation.

I have learned a great deal from the teaching, advice, and scholarship of EPP faculty members Jay Apt, Jeremy Michalek, Paul Fischbeck, Mitch Small, Marija Ilic, Paulina Jaramillo, and the late Lester Lave. I am thankful for the opportunity to teach and share my work with Engineering Technology Innovation Management (ETIM) students provided to me by EPP adjunct assistant professor and RAND engineer, Costa Samaras, and ETIM director, Eden Fisher. Life at EPP would not be so smooth without the commitment and warmth of Patti Sternachak, Barbara Bugosh, Vicki Finney, Adam Loucks, Steve Gradeck, and the rest of the EPP staff. While working at the Climate and Energy Decision-Making Center, I have also had the opportunity to learn from Hadi Dowladabati, Ann Bostrom, Dalia Echeverri, Rob Lempert, Michael Dworkin, Joe DeCarolis, and Tim McDaniels.

In my DC efficiency research, I have benefitted from useful discussions and references to data and relevant literature from Kevin Dowling, Clark Gellings, Ihor Lys, Fritz Morgan, and Le Tang. My rebound research started with a class project with Ranjani Theragowda and has benefitted from useful discussions with former EPP professor and current Science and Technology Policy Institute researcher, Chris L. Weber, University of Arizona professor, Lester Taylor, collaboration with Zeke Hausfather of C3 Energy, and data and discussions with Geoffrey Paulin, Steve Henderson, and Bill Passero of the Bureau of Labor Statistics. I would also like to thank the International Risk Governance Council (IRGC) and CEDM for their support in the organization of two international workshops on the topic of energy efficiency and the rebound effect. Feedback from the participants in these workshops was very helpful and helped to shape Chapter 3 of this dissertation.

I thank my Stanford undergraduate thesis advisor, David Victor, now at University of California, San Diego, for sparking my initial curiosity about social science experiments and communicating for policy and pointing me to EPP, as well as the support of Gil Masters and Pat Burchat at Stanford in helping me to transition from a physics major to an energy policy scholar.

My time at CMU has been a memorable experience due to the dynamic community of EPP graduate students past and present, including Shaz Attari, Rob Behrman, Mike Blackhurst, Lauren Fleishman, Royce Francis, Anny Huang, Alan Jenn, Warren Katzenstein, Jon Kowalski, Colleen Lueken, Russell Meyer, Hari Mantripragada, Alex Mateus, Jihoon Min, Anu Narayanan, David-Luke Oates, Ivonne Pena, Scott Peterson, Kate Ricke, Dan Schnitzer, Stefan Schweitzke, Vanessa Schweizer, Adam Tagert, Huimin Tan, Janice Tsai, and Sharon Wagner, students from the broader CMU community, including Ishani Aggrawal, Shriya Joag, Anusha Venkatramani, and my EPP cohort and friends, Shira Horowitz, Kim Mullins, Eric Hittinger, Rachael Hittinger, Amy Nagengast, Shantanu Jathar, Tim Gordon, Peter Versteeg, Emily Fertig, Steve Rose, Catherine Izard, Marla Sanchez, Rachael Nealer, Kyle Siler-Evans, Kelly Klima, and Brandon Mauch. I thank my parents, Thomas Abraham and Briget Thomas, my brother, Brian, and my sister, Brislin, for their love and support during this process. Last but not least, I thank Neil Mehta for his love, patience, and encouragement and for making my time at CMU a happy one.

Energy Efficiency and Rebound Effects in the United States

Implications for Renewables Investment and Emissions Abatement

Brinda Ann Thomas

Abstract

By lowering the energy required to provide a service, energy efficiency can help society consume less energy, emit less CO₂e and other air pollutants, while maintaining quality of life. In this work, I examine a key benefit of energy efficiency, reducing renewables investment costs, and a side-effect, expanding energy service demand, also known as the rebound effect.

First, I assess the economics of an energy efficiency intervention, using dedicated direct current (DC) circuits to operate lighting in commercial buildings. I find that using DC circuits in grid-connected PV-powered LED lighting systems can lower the total unsubsidized capital costs by 4% to 21% and levelized annual costs by 2% to 21% compared to AC grid-connected PV LEDs providing the same level of lighting service. I also explore the barriers and limitations of DC circuits in commercial buildings.

Second, I examine the rebound effect from residential energy efficiency investments through a model in which households re-spend energy expenditure savings from an efficiency investment on more of the energy service (direct rebound) or on other goods and services (indirect rebound). Using U.S. household expenditure data and environmentally-extended input-output analysis, I find indirect rebound effects in CO₂e emissions of 5-15%, depending on the fuel saved and assuming a 10% direct rebound.

Third, I examine the variation in the indirect rebound from electricity efficiency across U.S. states due to differences in electric grid mix, fuel prices, household income, and spending patterns. I find that the CO₂e direct and indirect rebound effects vary across states between 6-

40%, when including full supply chain emissions, and between 4-30% when including only combustion and electricity emissions.

I conclude that energy efficiency can provide significant benefits for reducing energy expenditures, CO₂e and other pollutants, and renewables investment costs under policy mandates, even after accounting for the rebound effect. While the CO₂e rebound effect is currently modest in the U.S., there are some exceptions that may be relevant for energy efficiency policy assessments. In addition, more data collection and measurements of direct rebound effects are needed, especially in developing countries where the demand for energy services has not fully been met.

Table of Contents

Chapter 1: Overview and Motivation	1
1.1 The Energy Efficiency Policy Context	1
1.2 Advantages of Energy Efficiency	2
1.3 The Energy Efficiency Gap	3
1.4 Rebound Effects	4
1.5 References	6
Chapter 2: Edison Revisited: Should we use DC circuits for lighting in commercial buildings?	8
Abstract	8
2.1 Introduction	8
2.2 Methodology	12
2.2.1 Grid-connected DC Lighting System Design	15
2.2.2 Solar Photovoltaic System Design (Without Energy Storage)	16
2.2.3 Integrated Solar PV Array and Battery Storage Design	19
2.3 Results	20
2.3.1 The Economics of Grid-powered DC LEDs	20
2.3.2 The Economics of Grid-connected PV-powered DC LEDs	23
2.3.3 The Economics of Grid-connected PV-powered DC LEDs with Battery Back-up	24
2.4 Discussion and Conclusion	25
2.5 References	28
2.6 Supporting Information	32
2.6.1 Lighting System, Power Electronics, and Wiring System Characteristics	32
2.6.2 Engineering Design and Economic Model Inputs and Outputs	36
Chapter 3: Estimating Direct and Indirect Rebound Effects for U.S. Households with Input-Output Analysis	46
Abstract	46
3.1 Motivation and Literature Review	47
3.2 Methods	54
3.3 Data	66
3.3.1 Energy Service Own-Price Elasticities for Direct Rebound Effects	66
3.3.2 U.S. Consumer Expenditure Survey	67
3.3.3 Expenditure Elasticities	68
3.3.4 U.S. Household Expenditures, Spending Patterns, and Environmental Footprints	69
3.4 Results	71

3.4.1	Indirect Rebound Effects Vary by Policy Goal and Type of Fuel Efficiency.....	72
3.4.2	Responding Scenarios for Direct and Indirect Rebound Effects.....	76
3.4.3	Sensitivity Analyses for the Indirect Rebound Effect.....	79
3.4.4	Direct and Indirect Rebound Effects Vary by Household Income.....	81
3.5	Discussion and Conclusion.....	84
3.5.1	Reliability of the Results.....	84
3.5.2	Relevance of Results.....	85
3.6	References.....	87
3.7	Supporting Information.....	93
3.7.1	Literature Review of Direct and Indirect Rebound Studies.....	93
3.7.2	Slutsky Model of Price Elasticities and Rebound Effects.....	97
3.7.3	Derivation of Indirect Rebound by Construction of Cross-Price Elasticities.....	101
3.7.4	Embodied Primary Energy and Emissions Intensities.....	103
3.7.5	Background on the Consumer Expenditure Survey.....	103
Chapter 4: A Regional Assessment of Direct and Indirect Rebound Effects in the U.S. for Electric End-Uses.....		105
	Abstract.....	105
4.1	Motivation.....	105
4.2	Direct and Indirect Rebound Model.....	110
4.3	Data.....	114
4.3.1	Price Elasticity of Energy Services.....	116
4.3.2	Budget Shares and Prices for Electricity and Gasoline.....	116
4.3.3	Budget Shares for Other Goods.....	117
4.3.4	Income Elasticities.....	117
4.3.5	Grid Emissions Factors.....	117
4.3.6	Emissions Per Dollar of Other Goods Expenditure.....	119
4.4	Direct and Indirect Rebound Results.....	119
4.4.1	Consequences of Emissions Rebound Depend on Abatement Objective.....	120
4.4.2	Rebound Effects are Small Relative to Household Carbon Footprints.....	123
4.5	Application of Rebound Results in Policy Analysis.....	126
4.6	References.....	128
4.7	Supporting Information.....	133
4.7.1	Overview of Input-Output Analysis.....	133
4.7.2	U.S. Income Elasticities, Average, and Marginal Spending Shares.....	134

4.7.3	EPA eGRID and NERC region boundary maps.....	135
4.7.4	Emissions Impact by Spending Category.....	136
4.7.5	Direct and indirect CO ₂ e rebound results by state.....	138
4.7.6	Direct and indirect NO _x rebound results by state	141
4.7.7	Direct and indirect SO ₂ rebound results by state.....	145
Chapter 5:	Conclusion	149
5.1	Summary of Thesis	149
5.2	Energy Efficiency with DC Circuits: Summary, Implications, and Future Work.....	149
5.3	Residential Rebound Effects: Summary, Implications, and Future Work	151
5.4	References	157

List of Figures

Figure 1-1: Global carbon mitigation opportunities.....	2
Figure 1-2: Rebound Taxonomy for residential energy efficiency.....	5
Figure 2-1: Schematic of commercial office building lighting system with AC vs. DC architectures.....	13
Figure 2-2: Load Profiles for LED Lighting system vs. solar PV output in Pittsburgh, PA.....	18
Figure 2-3: Levelized Annual Costs for AC vs. DC fluorescent and LED lighting systems.....	21
Figure 2-4: 2010-2020 LAC projections for grid-connected AC vs. DC fluorescent and LED lighting systems.....	22
Figure 2-5: Economics of DC lighting systems depend on the relative cost of DC vs. AC load power supplies.....	23
Figure 2-6: Levelized Annual Costs (in 1000\$ per year) for grid-connected PV-powered AC and DC lighting systems.....	24
Figure 2-7: 2012 and 2030 Lighting system LAC projections vs. fraction of load provided by solar PV and batteries.....	25
Figure 3-1: Annual expenditures and emissions for the average U.S. household in 2004.....	70
Figure 3-2a-b: (A) 2004 average U.S. household carbon footprint. (B) Comparison of re-spending patterns for electricity service efficiency.....	71
Figure 3-3: 2004 average U.S. household embodied GHG emissions with energy efficiency investments in electricity, natural gas, and gasoline services, after accounting for direct and indirect rebound effects.....	74
Figure 3-4a-d: Direct and indirect rebound effects vary by fuel type and environmental impact of consumption, whether primary energy or CO ₂ , NO _x , or SO ₂ emissions.....	75
Figure 3-5a-c: Direct and indirect rebound effects for (A) electricity efficiency, (B) natural gas efficiency, and (C) gasoline efficiency under re-spending scenarios using proportional spending, income elasticities, and cross-price elasticities.....	78
Figure 3-6a-c: Indirect Rebound Effects in CO ₂ e for efficiency investments reducing average U.S. household expenditures in energy services from (A) electricity, (B) natural gas, and (C) gasoline.....	80
Figure 3-7a-b: Direct and indirect rebound effects in (A) electricity efficiency and (B) gasoline efficiency decline with income.....	82
Figure 3-8: Consequences in CO ₂ e emissions of direct and indirect rebound effects from reducing 10% of annual electricity bills with efficiency for the average household in each income bracket.....	83
Figure 3-9: Slutsky Decomposition Analysis of the Rebound Effect. The direct and indirect rebound effects can both be decomposed into substitution and income effects in response to a change in the price of energy services with an efficiency investment.....	99
Figure 3-10a-d: Rebound in Energy Services vs. Energy Consumption. Graphs A, C show how an increase in demand for energy services due to the lower price of energy services can still lead to a net reduction of energy consumption, in Graphs B, D, with a rebound effect less than 100%.....	100
Figure 4-1a-d: Direct and indirect rebound effects in CO ₂ e emissions by state.....	122
Figure 4-2a-c. (A) Household carbon footprints, (C) direct and indirect rebound effects, and (C) net CO ₂ e savings for 5 electricity service efficiency scenarios for the average household in California, Minnesota, and the U.S.....	125

Figure 4-3: EPA eGRID region boundaries.	135
Figure 4-4: NERC region boundaries.	136
Figure 4-5: U.S. average supply chain (scope 1-3) CO ₂ e emissions per dollar of expenditure, E _S and E _O , for energy service and other goods at 2004 U.S. average prices in 2002\$.	136
Figure 4-6: U.S. average supply chain (scope 1-3) NO _x emissions per dollar of expenditure, E _S and E _O , for energy service and other goods at 2004 prices in 2002\$.	137
Figure 4-7: U.S. average supply chain (scope 1-3) SO ₂ emissions per dollar of expenditure, E _S and E _O , for energy service and other goods at 2004 prices in 2002\$.	137
Figure 4-8a-d: Direct and indirect rebound effects in NO _x emissions by state.	141
Figure 4-9a-d: Direct and indirect rebound effects in SO ₂ emissions by state.	145

List of Tables

Table 2-1: 2010-2030 LED, PV, and Battery Projections	14
Table 2-2: Base-case Fluorescent and LED Lighting System Parameters.....	33
Table 2-3: Lighting System Power Supply Parameters	33
Table 2-4: AC-DC Power Supply Costs	34
Table 3-1: Houthakker-Taylor Expenditure Elasticities used in Rebound Simulations	68
Table 3-2: Selected review of U.S. direct rebound studies using energy services model	93
Table 3-3: Literature Review of Direct and Indirect Rebound Studies.....	94
Table 3-4: Primary energy-, CO ₂ e-, NO _x -, and SO ₂ -intensities, E _s and E _o , per dollar of household expenditure for 13 categories.....	103
Table 4-1: Summary of data sources and geographical detail	115
Table 4-2: 2004 Expenditure (Income) Elasticities and Marginal Spending for U.S. households	134
Table 4-3: State-level CO ₂ e direct and indirect rebound results	138
Table 4-4: State-level NO _x direct and indirect rebound results.....	142
Table 4-5: State-level SO ₂ direct and indirect rebound results	146

Chapter 1: Overview and Motivation

1.1 The Energy Efficiency Policy Context

Since its initial entry into the energy policy landscape with the energy crises of the 1970s, energy efficiency has been called on to accomplish increasingly diverse goals, from reducing investment costs in new generation, improving the reliability of electric systems, creating new jobs and industries, and reducing carbon dioxide and other pollutant emissions at the lowest cost. In the U.S., energy efficiency has been a key part of all major energy legislation from the establishment of national appliance and fuel economy standards in late 1970s, to the \$17 billion investment in energy efficiency programs in the American Recovery and Reinvestment Act (ARRA) of 2009 (ACEEE, 2009). At the state level, efficiency programs, often funded by utilities through public benefits charges, have grown from a low of \$900 million in 1998 to \$4.6 billion in 2010, largely as energy efficiency resource standards (EERS) have been instituted in over 20 states (ACEEE, 2012; DSIRE, 2012a). Internationally, energy efficiency forms one leg of the European Union's 20-20-20 climate and energy plan, with a goal to reduce 20% of primary energy consumption by 2020 (European Commission, 2012). China plans to reduce its energy intensity of GDP by 17% from 2011-2015 (Jiabao, 2011) and India has developed energy benchmarking programs, building codes, and appliance standards for its energy efficiency goals (Raghuraman, 2012). According to the IEA, energy efficiency will contribute to over two-thirds of the Organization for Economic Cooperation and Development (OECD) countries' carbon abatement opportunities in 2020 and over half of all carbon abatement opportunities in 2030, as seen in Figure 1-1.

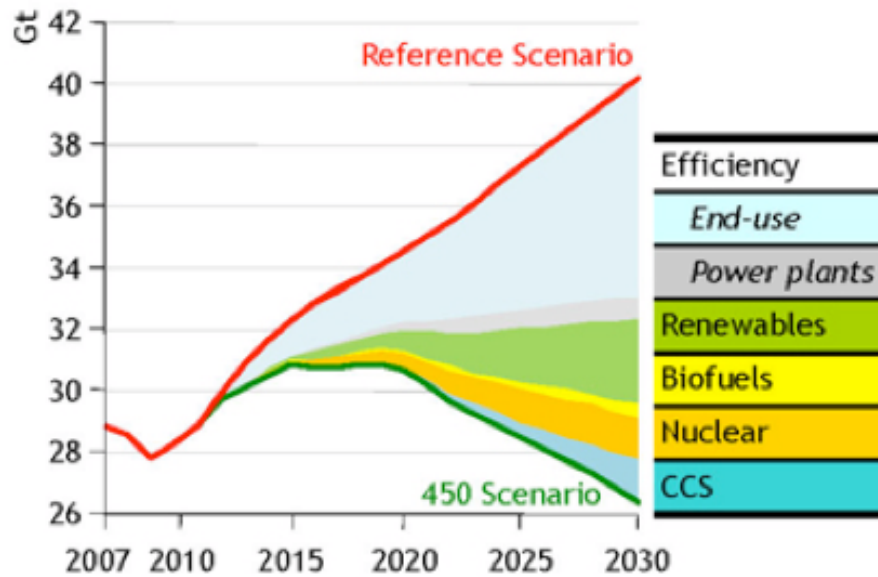

Figure 1-1: Global carbon mitigation opportunities.
Reproduced from IEA, 2009

1.2 Advantages of Energy Efficiency

One advantage of energy efficiency is that it can lower the baseline level of electricity demand and the absolute investment requirements in higher-cost renewable generation and transmission lines needed to meet policies such as the renewable portfolio standards in 29 U.S. states (DSIRE, 2012b). In the first part of this dissertation, Chapter 2, we assess the economics of a systems-level energy efficiency intervention, direct current (DC) circuits, also called microgrids (Marnay et al., 2011), for commercial buildings, especially focusing on the cost implications for integration of solar power, energy storage, and efficient lighting.

Another key advantage of energy efficiency is its life-cycle cost-effectiveness relative to investments in new generation, as suggested by energy efficiency potential studies (Meier, et al., 1983; National Academy of Sciences, 1992; Brown et al., 2001; McKinsey and Co, 2009; Azevedo, 2009). A recent energy efficiency potential study suggests that in 2020, up to 9 quads or 23% of total energy consumption could be saved with negative net costs, but with limited

disclosure of assumptions (McKinsey, 2009). Azevedo (2009) points to a more limited set of net cost saving opportunities of 3 quads of U.S. residential energy consumption in 2009, with fuel switching, or only 0.5 quads, with limited fuel switching and when accounting for the useful life and value of the existing capital stock. In addition, there are high upfront capital costs for these efficiency investments, amounting to over 0.5 trillion dollars (Azevedo, 2009).

1.3 The Energy Efficiency Gap

High capital costs join a number of other factors that limit the pace of investment in energy efficiency, in what is known as the energy efficiency paradox or gap (Sharma, 1983; Jaffe and Stavins, 1994; Sanstad and Howarth, 1994). The energy efficiency gap is characterized by the empirical observation of high (30-300%) discount rates used by consumers and firms in evaluating various energy efficiency investments (Hausman, 1979; Gately, 1980). Proposed causes for this gap include imperfections in markets for energy efficiency (Sanstad and Howarth, 1994) such as constraints in capital markets, imperfect information or asymmetric information available about the efficient products, transaction action costs involved with obtaining information, and institutional barriers due to the low salience of energy costs in firms. In addition, there are non-market barriers such as risk aversion, uncertainty about the benefits of the technology, and heterogeneity in the benefits for consumers and firms (Jaffe and Stavins, 1994), the difference between technology performance in engineering calculations and real-world conditions (Vine et al., 1994) and the inherent slow process of diffusion and adoption of economically beneficial technologies (Griliches, 1957). The energy efficiency gap has been used as justification for government intervention in energy efficiency markets through appliance and vehicle standards, efficiency tax credits and other subsidies, although some authors argue that

empirical evidence for a significant energy efficiency gap is limited (Allcott and Greenstone, 2012).

1.4 Rebound Effects

In addition, researchers have questioned the common engineering assumption that consumers require the same level of energy services before and after an efficiency investment, in research on the rebound effect. The rebound effect is a modern reinterpretation of the “Jevons’ paradox” which states that improved resource productivity in factors of production, for coal-fired steam engines in particular, lead to increased resource consumption (Jevons, 1865). Khazzoom (1980) revisited the Jevons’ paradox concept as a critique of the energy savings possible from energy efficiency standards resulting from changes in consumer utilization behavior, spurring a significant literature in energy economics, industrial ecology, and other social sciences.

Macroeconomic or top-down energy systems models may capture rebound effects already to the extent that energy efficiency investments lower the aggregate demand for energy, which induces greater energy consumption, as measured by the own-price elasticity of energy. This phenomenon has been called the economy-wide rebound effect and has been studied through macroeconomic models or dynamic general equilibrium models of the economy.

The economy-wide rebound effect can be divided into several components (Greening et al., 2000; Sorrell, 2007), which can be measured for either the residential, commercial, or industrial sectors, often using microeconomic models. Figure 1-2 shows a taxonomy of rebound effects in the residential sector, the focus of the second part of this dissertation. The direct rebound effect, describes the situation in which a consumer may use an efficient product more often or more intensively if it costs less to operate. For example, a homeowner may leave a CFL turned on more often than an incandescent lamp because the cost of light is much lower. The indirect

rebound effect describes the case in which the energy cost savings from an efficiency investment are re-spent on other goods or services which require energy for their production. For example, the homeowner may use electricity cost savings for a new TV or overseas vacation. Lastly there are other secondary or macroeconomic effects, such as changes in economic structure, a lower market price of energy, and disinvestment in the energy supply sectors (Turner, 2009), which are studied in macroeconomic models.

<p style="text-align: center;">potential energy savings</p> <p style="text-align: center;"><i>engineering or econometric estimate</i></p> <hr/> <p style="text-align: center;"><i>input-output analysis estimate</i></p> <hr/> <p style="text-align: center;"><i>general equilibrium estimate</i></p>	actual energy savings			
	Economy-wide Rebound Effect	direct rebound effect	substitution effects	own-price elasticity of demand for energy services
			income effects (residential)	
		indirect rebound effect	substitution effects	cross-price elasticity of demand for non-energy services
	income effects (residential)			
		embodied energy	supply-chain energy from fixed price input-output model	
	secondary effects		macroeconomic effects from general equilibrium model	

Figure 1-2: Rebound Taxonomy for residential energy efficiency. Sources/Notes: The left-most column represents engineering or other ex ante estimates of energy savings with efficiency, either at the scope of a household or in a static (input-output analysis) or dynamic general equilibrium framework. The right-most columns represent the parameters or models used to measure various types of rebound effects. Figure and taxonomy are adapted from Sorrell, 2007, with the addition of model scope and measurement descriptions.

The direct and indirect rebound effects in the residential sector are the focus of the second part of this dissertation. Chapter 3 develops a model to estimate the direct and indirect rebound effect using microeconomics and an input-output life cycle assessment tool from the field of industrial

ecology. This model is applied to expenditure data for the average U.S. household and sensitivity analyses are conducted to understand the drivers of the indirect rebound effect. In Chapter 4, the model is applied to state-level household energy expenditure and price data to assess the regional variation in the direct and indirect rebound effect.

Given the benefits of end-use and systems-level energy efficiency as well as the limits to efficiency posed by the energy efficiency gap and rebound effects, in Chapter 5 we discuss the path forward for policy interventions in energy efficiency. Our evidence on the rebound effect indicates that it is modest to moderate, and that efficiency policies do achieve the goal of reducing energy demand. However, rebound effects in carbon dioxide-equivalents (CO₂e) and other emissions can be large enough in some cases that they should be included in the planning process for energy efficiency policies at the local, state, national, and/or international levels. In addition, there are significant limitations on the data needed to assess the rebound effect, and areas for future study which we discuss in Chapter 5.

1.5 References

- Allcott, H. and Greenstone, M. (2012). “Is there an Energy Efficiency Gap?” *Journal of Economic Perspectives* 26, 3-28.
- Azevedo, I. L. (2009). “Energy Efficiency in the U.S. Residential Sector: An Engineering and Economic Assessment of Opportunities for Large Energy Savings and Greenhouse Gas Emissions Reductions.” Ph.D. Dissertation. Carnegie Mellon University.
- American Council for an Energy Efficient Economy (ACEEE). (2012a). “American Recovery and Reinvestment Act of 2009.” <http://aceee.org/topics/arra>
- Brown, M. A., Levine, M., Romm, J. P., Rosenfeld, A. P., and Koomey, J. G. (1998). “Engineering–Economic Studies of Energy Technologies to Reduce Greenhouse Gas Emissions: Opportunities and Challenges.” *Annual Review of Energy and the Environment* 23, 287–385.
- DSIRE. (2012a). “Energy Efficiency Resource Standards.” Summary Map. <http://www.dsireusa.org/summarymaps/index.cfm?ee=0&RE=0>
- DSIRE. (2012b). “Renewable Portfolio Standards Policies.” Summary Map. <http://www.dsireusa.org/summarymaps/index.cfm?ee=0&RE=0>
- European Commission. (2010) “The EU Climate and Energy Package.” http://ec.europa.eu/clima/policies/package/index_en.htm

- Gately, D. (1980). "Individual Discount Rates and the Purchase and Utilization of Energy-Using Durables: Comment." *Bell Journal of Economics* 11, 373-374.
- Greening, L. A., Greene, D. L., and Difiglio, C., 2000. Energy efficiency and consumption -- the rebound effect -- a survey. *Energy Policy* 28, 389-401.
- Griliches, Z. (1957). "Hybrid Corn: An Exploration in the Economics of Technological Change." *Econometrica*. 25, 501-522.
- Hausman, J. (1979). "Individual Discount Rates and the Purchase and Utilization of Energy-Using Durables." *Bell Journal of Economics* 10, 33-54.
- International Energy Agency (IEA), 2009. *World Energy Outlook*. Figure 5-8.
- Jaffe, A. B. and Stavins, R. N., 1994. The energy efficiency gap: What does it mean? *Energy Policy* 22, 804-810.
- Jevons, S. (1865). *The Coal Question: An Inquiry Concerning the Progress of the Nation, and the Probable Exhaustion of Our Coal Mines*. London Macmillan and Co.
- Jiabao, W. (2011.) Speech at Annual Meeting of the New Champions.
http://english.gov.cn/2011-09/14/content_1947644_3.htm
- Khazzoom, J.D., 1980. Economic implications of mandated efficiency in standards for household appliances. *Energy Journal* 1, 21-40.
- Meier, A., Wright, J., and Rosenfeld, A. H. (1983). "Supplying Energy through Greater Efficiency: The Potential for Conservation in California's Residential Sector." Berkeley, CA: University of California Press.
- Marnay, C., Nordman, B., and Lai, J. (2011). "Future Roles of Milli-, Micro-, and Nano-Grids." CIGRE International Symposium. Bologna, Italy. 13-15 September.
- McKinsey & Company. (2009). "Unlocking Energy Efficiency in the U.S. Economy."
- National Academy of Sciences. (1992). "Policy Implications of Greenhouse Warming: Mitigation, Adaptation, and the Science Base." Washington, DC:
- Raghuraman, V. (2012). Presentation at Confederation of Indian Industry.
http://www.teriin.org/events/docs/present_japan/sess1/v_raghuraman.pdf
- Sanstad, A. and Howarth, R. (1994). "Normal Markets, Market Imperfections and Energy Efficiency." *Energy Policy* 22, 811-818.
- Sorrell, S., 2007. *The Rebound Effect: an assessment of the evidence for economy-wide energy savings from improved energy efficiency*. UK Energy Research Centre Technical Report.
- Sharma, A. "Energy Conservation in U.S. Buildings: Solving the high potential/low adoption paradox from a behavioral perspective." *Energy Policy*. 148-167.

Chapter 2: Edison Revisited: Should we use DC circuits for lighting in commercial buildings?ⁱ

Abstract

We examine the economic feasibility of using dedicated DC circuits to operate lighting in commercial buildings. We compare light-emitting diodes (LEDs) and fluorescents that are powered by either a central DC power supply or traditional AC grid electricity, with and without solar photovoltaics (PV) and battery back-up. Using DOE performance targets for LEDs and solar PV, we find that by 2012 LEDs have the lowest levelized annualized cost (LAC). If a DC voltage standard were developed, so that each LED fixture's driver could be eliminated, LACs could decrease, on average, by 5% compared to AC LEDs with a driver in each fixture. DC circuits in grid-connected PV-powered LED lighting systems can lower the total unsubsidized capital costs by 4% to 21% and LACs by 2% to 21% compared to AC grid-connected PV LEDs. Grid-connected PV LEDs may match the LAC of grid-powered fluorescents by 2013. This outcome depends more on manufacturers' ability to produce LEDs that follow DOE's lamp production cost and efficacy targets, than on reducing power electronics costs for DC building circuits and voltage standardization. Further work is needed to better understand potential safety risks with DC distribution and to remove design, installation, permitting, and regulatory barriers.

2.1 Introduction

In 1891, as the "Battle of the Currents" was coming to a close, the board for the Chicago World's Fair received two bids to illuminate the world's first all-electric fair: General Electric proposed a \$1.8 million (later reduced to \$554,000) direct current (DC) generator and distribution network, while the Westinghouse Electric Company submitted the winning bid of \$399,000 for an

ⁱ This chapter has been published as B. A. Thomas, I. L. Azevedo, and M. G. Morgan. (2012). "Edison Revisited: Should we use DC circuits for lighting in commercial buildings?" *Energy Policy*, 45, 399-411. The chapter includes minor editorial revisions from the published version.

alternating current (AC) system (all costs in 1891 dollars) (Larson, 2003). The years that followed saw the decline of Thomas Edison's pioneering 110 V DC distribution systems. AC long-distance transmission and distribution became standard because the AC transformer made it possible to step voltage up for long distance power transfer and then back down for end use. High voltage AC achieved much greater efficiency for electric power transmission than low voltage DC, since resistive power losses grow as the square of the current, while the amount of power transferred is proportional to the product of voltage and current. In the early 20th century, high voltage DC transmission was not possible due to the lack of a "DC transformer."

However, in recent decades, new semiconductor materials and devices have been developed that can effectively function as a "DC transformer" with efficient (>80%) and reliable designs (80plus.org, 2010). Today, high-voltage DC (HVDC) (200-800kV) has become the most cost-effective option for point-to-point electricity transmission across distances greater than 500-600 miles (e.g. connecting hydropower in the Pacific Northwest to loads in Los Angeles). At these distances, the cost savings from using two conductors for HVDC transmission versus three conductors for AC transmission (Schavemaker and van der Sluis, 2008), outweigh the higher cost of DC power electronics compared to AC transformers. However, the economics are such that AC remains the norm for all local transmission and distribution systems.

The objective of this chapter is to assess the economics of DC distribution at the building level, which some analysts have proposed as an approach to reduce the cost and improve the efficiencies of power conversion (Babyak, 2006). There are two main motivations for this chapter. First, DC building circuits could reduce or eliminate the proliferation of power supplies that convert AC grid power to various DC voltages for use in many commercial and residential loads, such as computers, consumer electronics, and LED lighting. Many small inefficient "wall

warts" had efficiencies as low as 40% (Caldwell and Reeder, 2002) before they became subject to national (and international) energy efficiency standards, such as the minimum efficiency standards programs established by the Energy Policy Act of 2005 and Energy Independence and Security Act of 2007 (EISA, 2007) in the United States. Similar programs exist at the regional level (e.g. the California Energy Commission) and in other nations (e.g. Australian Greenhouse Office) (Mammano, 2007).

Second, DC building distribution may improve the power conversion efficiencies and lower the cost of using distributed generation (DG) that can inherently or easily produce DC power. Since the 1970s, DG has seen a rebirth due to converging goals to improve overall efficiency in the use of primary energy, the divestiture of large generation by some utilities that have been restructured as "wires companies" (Strachan, 2000), growing consumer concerns about supply reliability, and concerns about lowering greenhouse gas emissions. Some DG technologies such as solar photovoltaics (PV) and fuel cells inherently produce DC power, while other DG sources such as microturbines (30 kW – 1 MW) can easily produce DC power. Researchers have found that using DC distribution can reduce PV system capital costs by up to 25% by eliminating the inverter and increasing system efficiency so that a downsized PV array can provide the same electricity service (Jimenez, 2005; DTI, 2002). Using different assumptions, Hammerstrom (2007) reports that DC building circuits can only improve power conversion efficiency by 3% with the use of solar PV, fuel cells, or other DC DG, and impose a 2% energy efficiency penalty without DC DG. Given other uncertainties, whether these differences are significant is unclear.

The use of DC circuits would be a fundamental change in the electrical systems of commercial buildings and would pose many questions for engineering design, economics, and safety standards. Much previous research on building-level DC circuits has focused on those

applications with the most favorable economics and high AC-DC power conversion losses due to the use of DG-backup systems, batteries, and uninterruptible power supplies (UPS), such as power plant auxiliary systems, telecommunications facilities, and data centers (Jancauskas and Guthrie, 1995; Yamashita et al., 1999; Belady, 2007; Pratt et al., 2007; Ton et al., 2008). Broader application of DC building circuits may also be feasible with existing power supply and circuit breaker technologies (Sannino et al., 2003), since laboratory tests confirm that many household devices can readily accept DC power (George, 2006).

While DC circuits are technically feasible and may be cost-effective in specialized applications such as data centers, it remains unclear whether they are cheaper than AC power for broader applications such as lighting in office buildings, the most common type of commercial buildings in the U.S. (CBES, 2003). Here, we conduct Monte Carlo simulations of the levelized annual costs (LACs) for the installation and operation of lighting in commercial office buildings under six scenarios, three using centrally rectified DC with dedicated distribution circuits to power LEDs or fluorescents and three using conventional AC to power LEDs or fluorescents.

Specifically:

- 1) centrally rectified DC without PV;
- 2) centrally rectified DC with PV;
- 3) centrally rectified DC with both PV and battery backup;
- 4) conventional AC without PV;
- 5) conventional AC with PV; and,
- 6) conventional AC with both PV and battery backup

We limit our analysis to lighting. Other applications such as HVAC could operate with DC, but do not share the potential advantage posed by lighting of replacing many small power supplies with one central supply.

With present fluorescent and LED efficacies, we find that centrally rectified DC LED lighting systems have the lowest annualized cost (LAC). DC circuits in grid-connected solar PV-powered

LED lighting systems can lower the total unsubsidized capital costs of the system by 4 to 21% and LACs by 2 to 21% compared to a PV-AC lighting system, which may encourage some building owners to choose to install building-level DC circuits. However, DC circuits do not significantly accelerate the cost reductions of grid-connected PV-powered LEDs, since LED and PV costs are falling at a faster rate than power supply costs.

In the balance of the chapter, Section 2.2 provides detail about the key assumptions of our Monte Carlo simulation of commercial building DC lighting systems; Section 2.3 provides key results on the economics of centrally rectified DC LEDs, grid-connected PV-powered DC LEDs, and grid-connected PV-powered DC LEDs with battery back-up; and, we conclude in Section 2.4 with a discussion of policy implications.

2.2 Methodology

We constructed a model that, given a specification of office building geometry, occupancy, and lighting needs, estimates the power and energy consumption for the three DC and three AC scenarios listed above for LEDs and fluorescents, as seen in Figure 2-1. As an illustrative case-study, we examine a hypothetical four-story, 48,000 ft² (4,400 m²) new construction commercial office building for 670 occupants, with 1900 klm in ambient lighting and 330 klm in task lighting, based on Illumination Engineering Society of North America (IESNA) illuminance requirements for office spaces (Navigant Consulting, 2002), in Pittsburgh, PA. Model specifications can easily be changed for alternate commercial building case studies.

The AC scenarios consider 277 V AC fluorescent fixtures and 277 V AC LED fixtures. The DC scenarios consider 249 V DC (i.e. rectified 277 V AC) fluorescent fixtures and 249 V DC LED fixtures. We hold constant the number of fixtures and the number of lumens (lm) provided by the several lighting fixtures. The lighting system power is therefore the free variable. The

total lighting load is used to determine the wire lengths and diameters (gauges) for the ambient and task lighting systems. Details of the lighting system, power electronics characteristics, and wiring and circuit protection requirements are listed in Section 2.6.1 of the Supporting Information (SI). We do not consider the use of daylighting or lighting controls, although in some settings these can be highly cost-effective approaches to achieving higher lighting efficiency (Jennings et al., 2000).

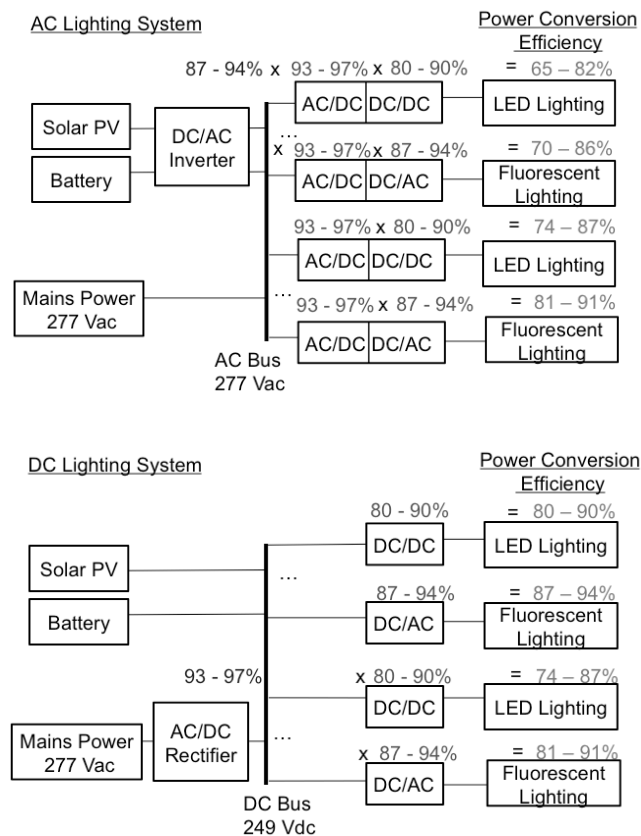

Figure 2-1: Schematic of commercial office building lighting system with AC vs. DC architectures.

Notes: If lighting fixture-level DC/DC power supplies could be eliminated for LED lighting systems, power conversion efficiencies would be improved to 93-97%. DC lighting systems could provide 8-17% greater power conversion efficiencies when used with grid-connected solar PV and battery back-up. Sources: Jimenez, 2005; George, 2006; Pratt, 2007.

We compare the six scenarios with fluorescent and LED lighting systems on the basis of levelized annual costs (LAC) and capital costs. LAC is a useful metric for evaluating AC versus DC lighting systems because it allows the comparison of systems with many components of varying lifetimes, taking into account the time value of money. The LAC estimates, in 2012\$/yr, are the sum of installation and capital costs for the lighting system ($CapLED/CapFL$), solar PV system ($CapPV$), and wiring and circuit breakers (W), levelized over their respective lifetimes, and annual lamp replacement labor costs (maintenance, M) and annual grid electricity costs (E) with \$0.10/kWh rates, as shown in Eq. 2-1:

$$LAC = CapPV * CRF_p + CapLED * CRF_L + W * CRF_w + M + E \quad 2-1$$

$$CRF_i = \frac{i}{1 - (1 + i)^{-lifetime_i}} \quad 2-2$$

where CRF is the capital recovery factor and i is equal to a discount rate of 12 percent.

Lighting and PV systems have a range of possible costs given the range in the efficiencies and costs of DC and AC circuit components, as shown in Table 2-1. In addition, there is considerable natural and site-specific variability in solar radiation, which is an important parameter in the size and cost of the solar PV module and overall LACs in the PV-integrated scenarios. To represent a range of LACs, these metrics were calculated using a Monte Carlo simulation of 1,000 runs, which randomly sampled from uniform distributions of the input parameters to generate a range of output values from which statistics are generated (details available in Section 2.6.2 of the SI).

Table 2-1: 2010-2030 LED, PV, and Battery Projections

	2010		2012		2015		2020		2030	
	Min	Max	Min	Max	Min	Max	Min	Max	Min	Max
SSL Int.-Lamp Cost (\$/klm)	38	52	18	24	8.5	12	4.3	5.8	1.7	2.3
SSL Device Efficacy (lm/W)	114	154	150	202	190	258	219	261	224	266
SSL Thermal Eff (%)	81	89	82	90	84	91	86	92	88	93
SSL Driver Eff (%)	83	87	84	88	87	91	90	94	90	94
SSL Fixture Eff (%)	81	89	82	90	85	91	87	92	89	94
SSL Driver Cost (\$/W)	0.58	1.33	0.51	1.17	0.43	0.98	0.31	0.72	0.17	0.39
PV Module Cost (\$/W _p)	2.3	6.1	2.1	5.7	1.9	5.3	1.2	3.9	0.2	2.6
PV Conversion Efficiency (%)	13	20	14	21	15	23	16	25	18	30
Inverter Cost (\$/W _p)	0.25	0.47	0.17	0.35	0.10	0.23	0.08	0.17	0.05	0.10
BOP Costs (\$/W _p)	1.9	3.1	1.2	2.8	0.6	2.6	0.5	2.0	0.4	1.3
Battery Cost (\$/Wh)	0.30	0.80	0.29	0.78	0.28	0.74	0.26	0.69	0.22	0.59

Sources/Notes: SSL costs (except for drivers) are from R&D targets in DOE (2011b). SSL Driver costs are assumed to be 12-15% (Philips, 2009) of integrated lamp costs in 2010, and then decline by 6% annually from 2010-2030 (Darnell, 2005). PV module costs and efficiencies are from Curtright et al. (2008) and IEA (2010) and inverter and balance of plant (BOP) costs are from RMI (2010) for the lower estimate and half of PV module costs from Curtright et al. (2008) for the upper estimate. Lead-acid battery costs are from a sample of Grainger.com products, assuming costs decline at 1.5% annually.

2.2.1 Grid-connected DC Lighting System Design

For the grid-connected DC lighting systems, centralized AC-DC power supplies (rectifiers) on each floor convert AC grid power to the voltage required by the lighting systems, as shown schematically in Figure 2-1. This design is similar to Redwood Systems' 48 V low-voltage LED lighting system (2010) and Emerge Alliance's 24 V design (Symanski and Watkins, 2010), which combine DC wiring with centralized LED drivers and advanced lighting controls to achieve energy savings. The economics of building-level DC circuits would then depend on the costs and energy efficiencies of centralized AC-DC power supplies and lamp load-level DC power supplies, such as fluorescent ballasts and LED drivers, versus those of the load-level AC ballasts and drivers needed with conventional AC building circuits. Centralized power supply capital costs, which depend primarily on output power rating, and energy efficiency calculations are listed in Section 2.6.1 of the SI.

Today, DC power supplies at the level of individual lamps, such as fluorescent ballasts and LED drivers, are often more expensive than their AC counterparts because DC power supplies are niche products with small market volumes. However, if building-level DC circuits were widely implemented, DC power supplies might become cheaper than AC power supplies because both are similar in design, but DC power supplies do not require circuitry such as AC-DC rectifier and power factor (PF) correction. AC power supplies need PF correction because they often introduce harmonics and other power quality issues into the electric system (Salomonsson and Sannino, 2006). Instead, the central AC-DC power supply performs these functions and the lamp-level DC power supplies perform other functions, such as maintaining the high frequencies and voltages required to fire a fluorescent lamp or regulating the current to prevent damage to an LED device. With the current AC transmission and distribution system, AC-DC conversion and PF correction are required in each DC device, imposing an energy efficiency penalty and added cost.

To represent the best case scenario for DC lighting circuits and to exclude the transition costs of creating a market for DC power supplies, we make a few simplifying assumptions about the cost of DC fluorescent ballasts and LED drivers. DC fluorescent ballasts are assumed to be half the cost of AC fluorescent ballasts. We also assume that an industry voltage standard is established, and that LED manufacturers design the lamps accordingly, so that LED drivers can be eliminated from DC LED lighting systems. Completely eliminating the driver is a strong assumption given the need for current regulation in LED devices, so we test the sensitivity of DC LED LACs to the relative cost of DC LED drivers versus AC LED drivers.

2.2.2 Solar Photovoltaic System Design (Without Energy Storage)

For the solar PV scenarios, we model a grid-connected commercial building with a solar PV array with fixed-tilt at latitude, that supplies supplementary electricity in a climate such as in

Pittsburgh, PA. Load profiles and solar PV output for the maximum, minimum and mean solar insolation levels in Pittsburgh, PA are shown in Figure 2-2. We model polycrystalline silicon solar PV, since it is readily available in the marketplace and subject to future R&D improvements. Hourly and monthly average solar radiation data were obtained from the National Renewable Energy Laboratory (NREL)'s National Solar Radiation Database. Using these data, the model estimates hourly and monthly grid- and solar PV- electricity consumption. The choice of the building site should not affect the relative levelized costs of DC versus AC distribution since parameters that vary by region such as insolation and electricity prices are held constant across all scenarios. However, variations in insolation do affect the size and total capital costs of the PV panel, which constitute a major portion of the LAC in the PV-integrated scenarios. Since Pittsburgh is a relatively cloudy site (NOAA, 2010), our estimates are likely to be an upper bound on absolute LACs with DC circuits and solar PV in the U.S.

Sizing the solar PV system is an important design consideration to minimize DC circuit LAC. An oversized PV system that produces more electricity than daily load requirements could require an inverter to sell the excess electricity to the electric grid, DC energy storage, or would waste excess PV electricity. All these options would increase the levelized cost of the system (Jimenez, 2005). Sizing the PV panel to minimize LAC is a rational approach, but this would not allow a comparison of scenarios with and without PV when PV LCOEs are greater than grid electricity prices (since the optimal PV size would then be zero watts). Given our interest in exploring not only the least cost scenarios, but also those that would increase the environmental sustainability of the overall system, we opted for a scenario where the solar PV array is sized to power the “base load” ambient lighting systems during the sunniest month of the year using the “peak hours approach” (Masters, 2004). The PV panel is modeled to provide equal energy end-use (lighting)

service in lumen-hours (lm-hrs) for all four lighting system options, in the case without energy storage, using:

$$PV(kW) = \frac{L}{\eta_{PV} * I * inv} \quad 2-3$$

where PV is the peak installed power capacity of the solar panel in kW_p, *L* is the building lighting system electricity load (kWh/day) in the sunniest month of the year, July, in Pittsburgh, η_{PV} is the module efficiency of the solar panel, which is between 12-18% (Curtright et al., 2008, DOE, 2007b), *I* is the daily insolation (h/day of peak sun = 1 kW/m²) in Pittsburgh in July, *inv* is the inverter efficiency, which is (87-94%) for the AC cases (and obviously 100% otherwise) (George, 2006). In months with less solar radiation, grid electricity supplies the part of the load not powered by solar PV. A consequence of the model's PV sizing rule is that each scenario has a different solar electricity production and solar PV module size, which varies between 16-42 kW_p or 1200-3300 ft² of the 12,000 ft² office building roof space, holding constant delivered lighting service in lm-hr/ft².

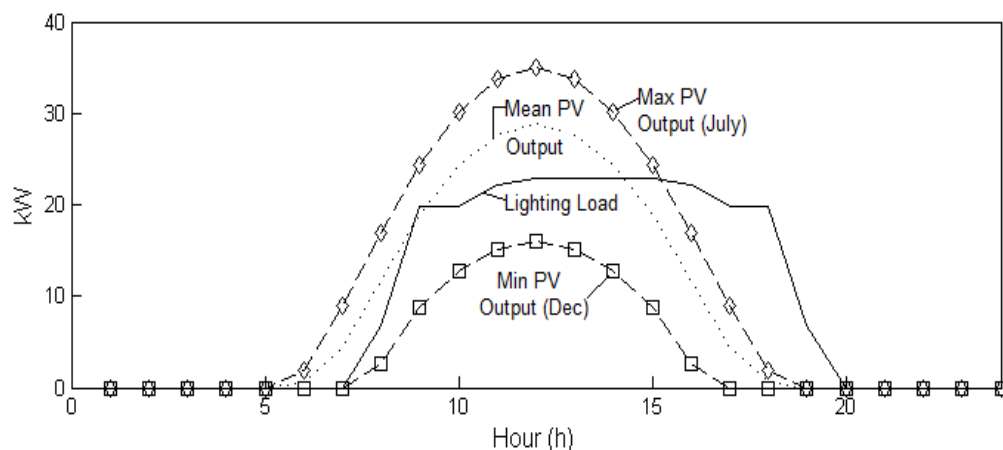

Figure 2-2: Load Profiles for LED Lighting system vs. solar PV output in Pittsburgh, PA. Notes: Load profiles generated from PV-integrated DC LED lighting systems with 100% of the load electricity requirements (on average over the year) provided by PV and energy storage. Sources: NREL, 2010; NOAA, 2010.

2.2.3 Integrated Solar PV Array and Battery Storage Design

To demonstrate how the addition of energy storage (in the form of simple lead-acid batteries) would influence the LACs of the four main lighting options, we also explore the case where the solar PV and energy storage system provides a fixed proportion of total lighting load, shown in Figure 2-2; this proportion is held constant across scenarios for comparison. We chose lead-acid batteries for simplicity and since they are a mature battery technology. In this case, the solar PV array is sized for a load of bL where $b \leq 1.0$, corresponds to the fraction of the lighting load served by the integrated PV-battery system. The lead acid battery bank is sized according to:

$$B = \max_t \left[\frac{PV * I_t - bL_t}{V\eta_d} \right] \quad 2-4$$

where B is the battery size in amp-hours(Ah), defined as the maximum state of charge needed to store any PV output not used by the lighting load at a given hour over the year, PV is the size of the photovoltaic array in kW_p, I_t is the hourly insolation, and V is the system voltage of the solar PV array and lighting system, and η_d is the battery discharge efficiency. In our model, we ignore the excess electricity stored in the battery at the end of the year; it could be used for other end-uses for the commercial building. For this design, we assume the same system voltage for the lighting and power generation system to preclude the use of additional power electronics, as seen schematically in Figure 2-1. We vary the proportion of electricity provided by PV and energy storage for the AC and DC fluorescent and LED lighting systems, and compare LACs with the base case AC fluorescent lighting system without solar PV.

2.3 Results

2.3.1 The Economics of Grid-powered DC LEDs

Figure 2-3 shows the results for the grid-powered scenarios. In 2012, LED lamps (either DC or AC) are the lowest-cost options for commercial office lighting systems on the basis of levelized annual costs (LACs). The ranges in Figure 2-3 and results reported in the chapter all correspond to plus or minus one standard deviation from the mean. As Figure 2-3 shows, removing the drivers and adding the central power supply for a DC LED lighting system would lead to a 5% (or ~\$2000/yr) reduction in the levelized annual costs (LAC) of the “best” (lowest cost and most-efficient) LED lighting system compared to the best AC LED lighting system in 2012. However, there is a range of costs and efficiencies for LED lighting system components, so that switching to AC grid power with centrally rectified DC for LED lighting systems could lead to an increase of 5% to a decrease of 15% in LACs (or +\$2,000/yr to -\$6,000/yr) and an increase of 2% to a decrease of 14% in capital costs (or +\$5,000 to -\$27,000). AC and DC fluorescents have similar LACs and capital costs. The LED lighting options have 5-13% lower LACs and 30-40% higher capital costs than the fluorescent options due to the high capital cost of LED lamps. A commercial building of this size would spend roughly \$26,000/year on lighting electricity costs, using EIA’s (2008) end-use energy consumption estimates, due to overlighting (Dau, 2003) and the limited use of incandescent lamps. In contrast, our base case AC fluorescent lighting system has an annual electricity cost of \$18,000/yr and we estimate that DC LEDs correspond to a reduction in overall electricity costs of 60% (to \$7,000/yr) compared to the AC fluorescent base case.

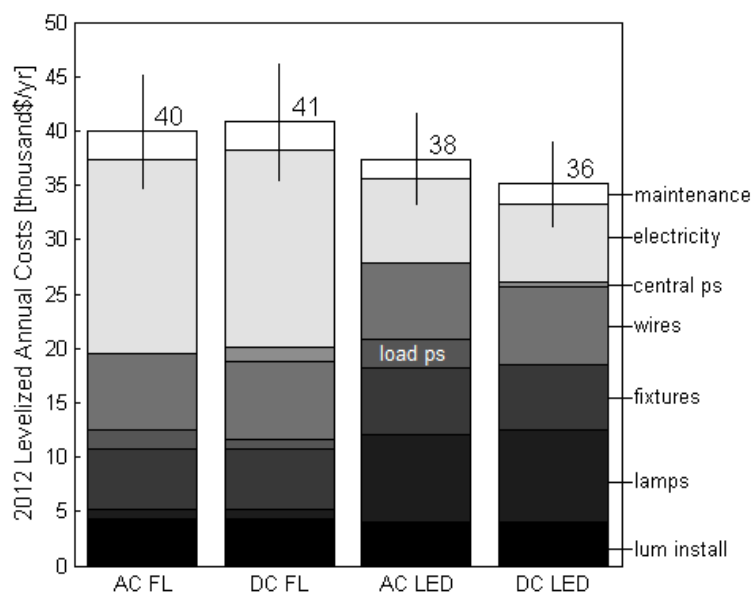

Figure 2-3: Levelized Annual Costs for AC vs. DC fluorescent and LED lighting systems. Notes: These results assume that DC circuits eliminate the need for LED drivers, and calculate LAC with a discount rate of 12% and electricity price of \$0.10/kWh. Error bars represent plus or minus one standard deviation of the LAC distribution. The LED cost of \$18-24/klm for an integrated lamp is from DOE's 2012 R&D targets (2011b). LED and fluorescent lamp and fixture costs are listed in Section 2.6.2 of the SI. AC FL = 277 V AC fluorescent lighting systems, DC FL = 249 V DC fluorescents, AC LED = 277 V AC LEDs, DC LED = 249 V DC LEDs. Lum install = luminaire installation cost, lamps + fix = lamp plus fixture equipment cost, ps = power supply.

From a policy perspective, it is more important to assure that manufacturers can produce LEDs that follow DOE's lamp production-cost and efficacy targets than it is to reduce power electronics costs with DC building circuits and voltage standardization. This can be seen in our simulations in Figure 2-4, in which both DC and AC LED lighting systems have matched AC fluorescent lighting system levelized annual costs by 2012, with the difference between AC and DC LED lighting systems declining over time. Compared to AC LED lighting systems, DC LED lighting systems reduce LACs by 6% (or \$2,000) in 2015 and by less than 2% (or <\$500) in 2020. These LAC calculations are most sensitive to the discount rate, luminaire fixture efficiencies, lighting requirements for the building, LED prices, and LED lifetimes.

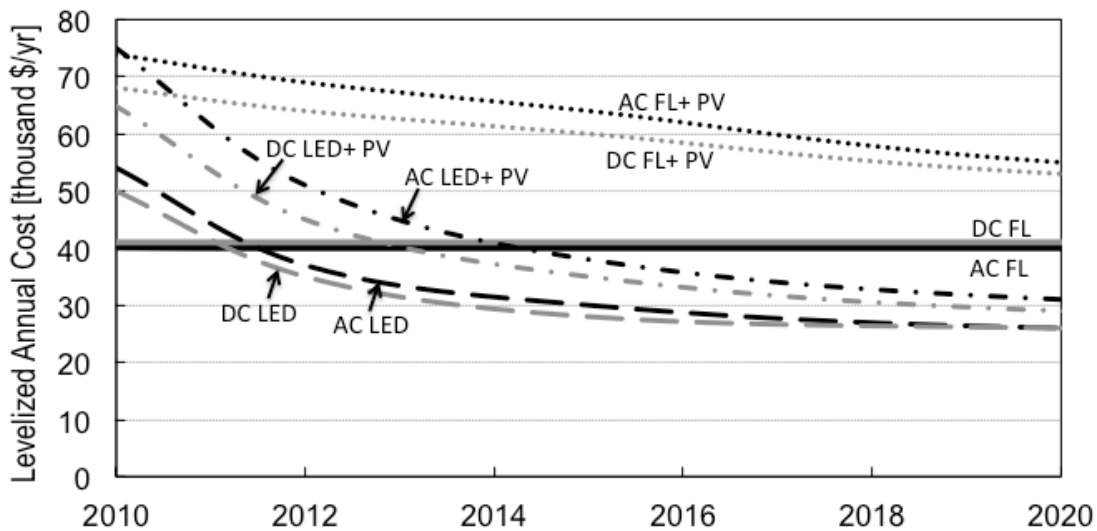

Figure 2-4: 2010-2020 LAC projections for grid-connected AC vs. DC fluorescent and LED lighting systems.

Notes: Results do not decline significantly between 2020-2030 and are excluded from the figure. The electricity price assumed is \$0.10/kWh, and the discount rate is 12%. LED projections are from DOE R&D targets, (2011b) and solar PV projections are from Curtright et al. (2008). These results assume that DC circuits eliminate the need for LED drivers and a PV inverter.

The results in Figure 2-3 and Figure 2-4 use the strong assumption that a DC voltage standard is in place so that no load-level DC drivers are needed for the LED lighting systems. However, as discussed previously, DC drivers may be needed to provide current regulation or other functions, whether or not a DC voltage standard is in place. Thus, in Figure 2-5, we relax the no-driver assumption to examine the breakeven DC driver/ballast cost for a DC lighting system to be lower-cost on a levelized annual cost basis than an AC lighting system. DC LEDs are lower cost than AC LEDs while DC drivers are less than 70% of the cost of AC drivers. Solar PV-powered DC LEDs are lower cost than their AC counterparts while DC drivers are less than 170% of the cost of AC drivers. Grid-powered DC fluorescents are always more expensive than AC fluorescents and solar PV-powered DC fluorescents are always less expensive than their AC counterparts under the range of power supply costs considered.

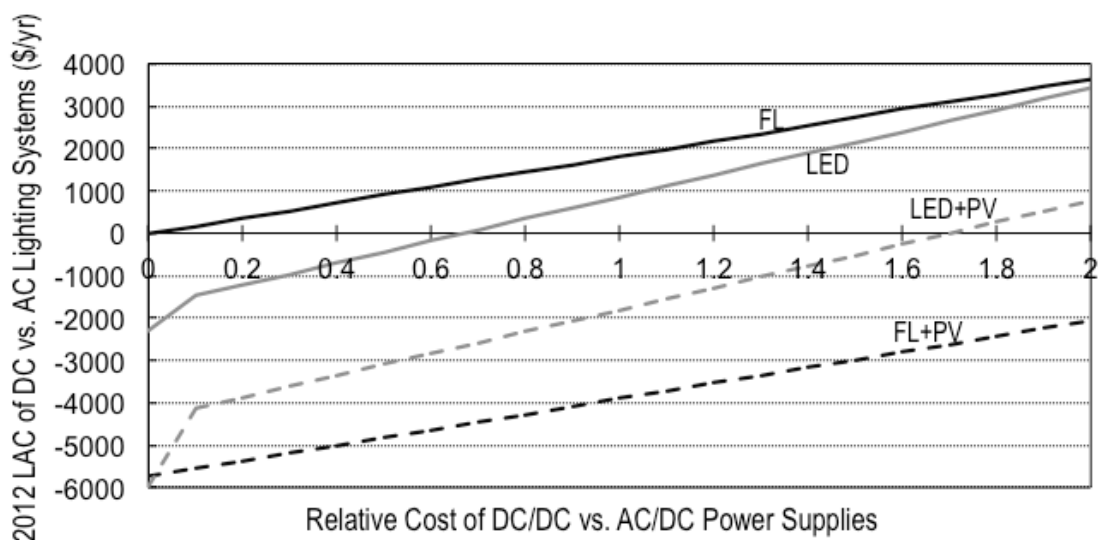

Figure 2-5: Economics of DC lighting systems depend on the relative cost of DC vs. AC load power supplies.

Notes: Power supplies include fluorescent lamp ballasts and LED drivers. Each scenario compares the LAC of the DC lighting system minus the LAC of the AC lighting system.

2.3.2 The Economics of Grid-connected PV-powered DC LEDs

Using a PV array output with the same voltage as the lighting system, one can eliminate an inverter (DC-AC) and other power electronics. By eliminating the inverter and load-level DC fluorescent ballasts and LED drivers, the PV arrays can be downsized by the extent of power conversion efficiency improvement, 14% and 22% with DC fluorescents and LEDs respectively, and still provide the same amount of ambient lighting service in $\text{lm}\cdot\text{hr}/\text{ft}^2$. Figure 2-6 shows that using the “best” (most-efficient) DC system with grid-integrated PV and LED lighting reduces LACs by 12% (or $\sim\$6,000/\text{yr}$) and capital costs by 13% (or $\sim\$39,000$) compared to the “best” PV-powered AC LED system. When considering the range in costs and efficiencies for PV and LED system components, DC circuits could lower LACs by 2-21% (or $\sim\$2,000/\text{yr}$ to $\$10,000/\text{yr}$) and could lower capital costs by 4-21% (or $\sim\$16,000$ to $\$62,000$) compared to a similar AC system.

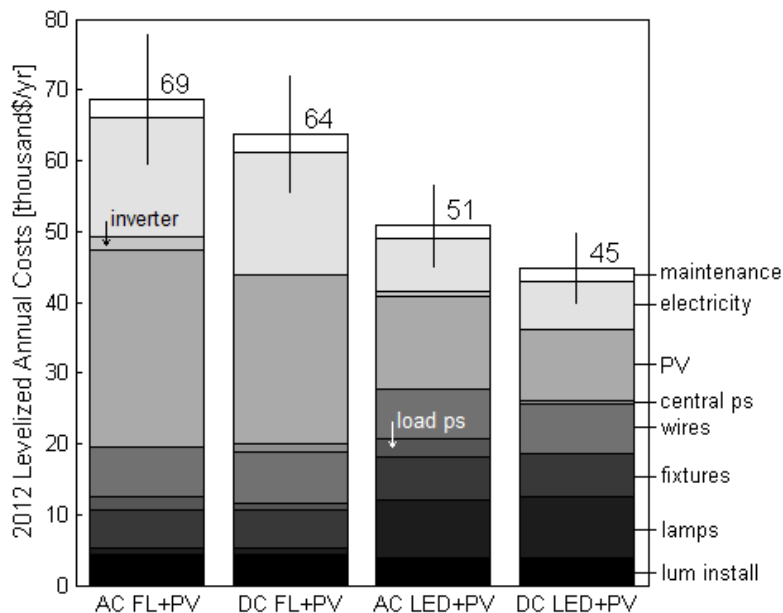

Figure 2-6: Levelized Annual Costs (in 1000\$ per year) for grid-connected PV-powered AC and DC lighting systems.

Notes: For these results, the discount rate = 12% and electricity price = \$0.10/kWh. Error bars represent plus or minus one standard deviation of the LAC distribution. These results assume that DC circuits eliminate the need for LED drivers. The LED cost of \$18-24/klm for an integrated lamp are from DOE's 2012 LED R&D targets (2011b), and solar PV costs of \$2.3-6.1/Wp are from Curtright et al. (2008). LED and fluorescent lamp and fixture costs are listed in Section 2.6.2 of the SI. AC FL+PV = 277 V AC fluorescents integrated with a 43 kW solar PV system, DC FL+PV = 249 V DC fluorescents integrated with a 37 kW solar PV system, AC LED+PV = 277 V AC LEDs with a 23 kW solar PV system, and DC LED+PV = 249 V DC LEDs with an 18 kW solar PV system. Lum install = luminaire installation cost, lamps + fix = lamp plus fixture equipment cost, ps = power supply.

The main cost drivers for a grid-integrated PV array powering an LED lighting system are the PV array and LEDs. By 2013, grid-integrated PV-powered LEDs match the LACs of grid-powered AC or DC fluorescents. However, even in 2020, the LACs of PV-powered DC LEDs are 12% higher than the LACs of AC or DC LED lighting systems without PV power, as seen in Figure 2-4.

2.3.3 The Economics of Grid-connected PV-powered DC LEDs with Battery Back-up

Using DC distribution with solar PV and batteries can eliminate the need for several power conversion stages, enabling the battery to provide power when the sun is covered by clouds or at

night, instead of using electricity from the grid. Today, crystalline silicon solar PV, lead-acid batteries, and LED lighting are far too expensive to compete with grid-connected AC fluorescent lighting systems (Curtright et al., 2008). However, if LEDs follow DOE's R&D targets for cost reductions (2011b) and solar PVs follow a path toward $\$0.60\text{-}2.60/W_p$ by 2030, which is the 95% confidence interval for crystalline silicon PV capital costs estimated by experts in Curtright et al. (2008), our simulations suggest that it will be cost-effective for a grid-connected PV with battery back-up to power up to 15% of the load from a DC LED lighting system by 2020, and up to 40% of DC LED lighting loads by 2030, compared to using grid-powered AC fluorescent lighting systems as seen in Figure 2-7.

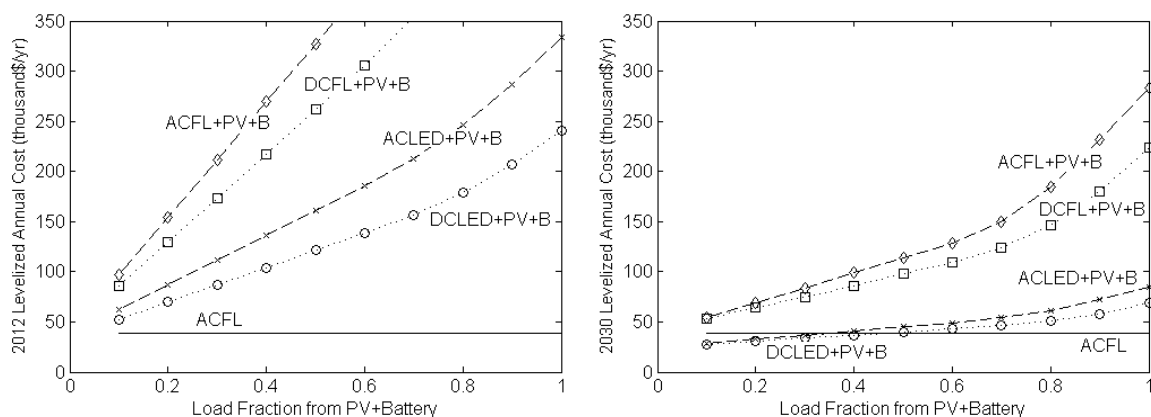

Figure 2-7: 2012 and 2030 Lighting system LAC projections vs. fraction of load provided by solar PV and batteries

2.4 Discussion and Conclusion

In 2012, assuming that the U.S. Department of Energy LED performance forecasts are correct, the use of LEDs for commercial building lighting systems appears to be a cost-effective strategy for reducing electricity consumption and associated CO₂ emissions whether the lamps are powered by AC or DC. Simulations in this work suggest that DC circuits could lead to an increase of 5% to a decrease of 15% in levelized annual costs (LACs) and an increase of 2% to a

decrease of 14% in capital costs for LED lighting systems compared to AC LEDs, provided that a DC voltage standard were established for building distribution and LED luminaires so that drivers in individual fixtures could be eliminated. The specific DC voltage standard chosen has limited impact on lighting system LACs because wiring energy losses and switch costs, which depend on distribution voltage, are small compared to the LED lighting and solar PV capital costs. If drivers are necessary, DC LEDs remain the lowest LAC option while DC drivers are under 70% or under 170% of the cost of AC drivers, in the grid-connected or solar-PV powered cases, respectively. DC circuits with solar PV-integrated LEDs (with grid power as needed and no battery storage) may match the LAC of grid-powered AC fluorescent lighting systems by 2013 but do not match the LAC of grid-powered DC LEDs, the lowest cost lighting option, before 2030. If states with solar provisions in state RPSs or states with PV subsidies (DSIRE, 2010) required all new construction of commercial office PV applications to use DC circuits, the LACs of the installations in 2012 could decline by 2-21% and capital costs could decline by 4-21%, further stretching subsidy dollars, whether in the form of electricity production or power capacity investment subsidies. However, given the large cost barriers that PV has yet to overcome, it is not clear that such subsidies would be good public policy.

There are several limitations to using DC distribution for LED lighting systems. First, there is a considerable range in the capital costs and energy efficiencies of various models of central AC-DC power supplies and drivers in individual fixtures. Detailed benchmarking of baseline capital cost and energy efficiencies of LED luminaire drivers would be needed to design a set of replacement central AC-DC power converters that provide cost savings. Second, the main cost driver for the LAC for LED lighting systems is the capital cost of the LED itself, which is 22% of the AC LED lighting system LAC, rather than LED driver costs, which are only 7% of LAC in

2012. Although 5% LAC savings, on average, may be realized by switching from an AC LED lighting system to a DC LED lighting system in 2012, these cost savings are non-significant and small relative to the Department of Energy's R&D targets that capital costs for LEDs (in \$/klm) will decline by over 10% annually during 2010-2020 through research and development (R&D). Third, as the AC LED driver and PV inverter steadily improve in energy efficiency and decline in cost, the savings in LACs and capital cost with DC circuits diminish over time. However, the use of DC circuits for a wider variety of end-use applications, such as building HVAC systems, computers, etc., where load-level power supply costs are flat or even slightly increasing over time (Darnell, 2011), might lower transition costs.

In the long term, DC building circuits can only lower costs if high-power AC-DC centralized power supplies can provide a cheaper alternative to rectifiers and power factor correction in many load-level power supplies. However, the century-long lock-in to AC systems poses a formidable barrier to the implementation of DC use in buildings. Power supplies, circuit protection, and other components designed for AC systems enjoy economies of scale in manufacturing, strong demand, and a large pool of trained engineers and technicians to control design and installation costs. At present, the small market for DC systems and small pool of qualified technicians results in high mark-ups for central AC-DC power supplies of kW-output power capacity, DC circuit protection, and installation, factors which have been ignored in our analysis. Standardization as well as training efforts would be essential if a transition to DC building circuits were to occur.

There are currently several industry-led standards for DC circuits in a variety of applications which may be adapted for commercial building lighting systems, such as the Emerge Alliance-led 24-V standards for lighting and 380-V standards for home appliances and plug-in hybrid electric chargers (Emerge Alliance, 2010), the 12 V standard for automobile drivetrains, the Universal

Serial Bus (USB) 5V, 12 V, and 24 V standards for powering computer electronics, and the IEEE-led 48 V power over ethernet (PoE) (IEEE, 2009) standard and efforts to develop a Universal Power Adapter for Mobile Devices (UPAMD) standard (IEEE, 2010). The application of some of these standards could help the development of a centralized AC-DC power supply market, a prerequisite for the wider application of DC circuits in commercial buildings.

Unless society places a higher value on power factor correction, RFI suppression, and improving reliability by minimizing power electronics components, at present the economics of DC building circuits are marginal. Thus, there is limited justification for strong technology-push subsidies to support a transition to DC building circuits at this time. However, the economics of DC building circuits may improve with more research and development in power electronics to support a variety of LED architectures, whether with centralized or load-level drivers. In addition, the regulator can ensure the development of any safety standards needed with DC wiring, especially for insulation and arc-quenching (see Supporting Information, Section 2.6.1) needed with high voltage DC circuits, in order to level the playing field and to avoid picking winners in a second round of the “Battle of the Currents.”

2.5 References

- 80plus.org, 2010. <http://www.80plus.org/>
- Azevedo, I. L., Morgan, M. G., Morgan, F., 2009. “The Transition to Solid State Lighting”. The Proceedings of the IEEE 97 (3), 481-510.
- Azevedo, I., 2007. “Energy Efficiency and Conservation: Is Solid State Lighting A Bright Idea?” ECEEE Summer Study. La Colle sur Loup, France.
- Babiyak, R., 2006. “Current Thinking.” Appliance Design Magazine. <http://www.appliancedesign.com/Articles/Departments/8184f80593d3a010VgnVCM100000f932a8c0>
- Belady, C., 2007. “In the data center, power and cooling costs more than the IT equipment it supports.” Electronics Cooling. <http://electronics-cooling.com/articles/2007/feb/a3/>
- Calwell, C., Reeder, T., 2002. “Power Supplies: A Hidden Opportunity for Energy Savings.” Ecos Consulting for Natural Resources Defense Council.

- Curtright, A. E., Morgan, M. G., and Keith, D. W., 2008. "Expert Assessments of Future Photovoltaic Technologies." *Environmental Science & Technology* 42 (24), 9031-9038.
- Dargatz, M., 2009. "DC Arc Faults and PV System Safety." *Renewable Energy World* 7. <http://www.renewableenergyworld.com/rea/news/article/2009/12/dc-arc-faults-and-pv-system-safety>
- Darnell Group, 2011 in Powerpulse.net. "AC-DC Pricing Trends Diverge from the Historic Norm." <http://www.powerpulse.net/story.php?src=r4;storyID=24942>
- Darnell Group, 2005 in DOE, 2006. "The Current and Projected Future Market for Battery Chargers and External Power Supplies." http://www1.eere.energy.gov/buildings/appliance_standards/residential/battery_external.html
- Dau, W., 2003. "The Right Amount of Light." *Buildings* 97 (8).
- DTI., 2002. "The Use of Direct Current Output From PV Systems in Buildings." <http://www.berr.gov.uk/files/file17277.pdf>
- DOE, 2011a. "Energy Conservation Standards for Fluorescent Lamp Ballasts: Final Rule." *Federal Register*, 76 FR 70548. http://www1.eere.energy.gov/buildings/appliance_standards/residential/fluorescent_lamp_ballasts.html
- DOE, 2011b. Solid-State Lighting (SSL) Multi-Year Program Plan (MYPP), Washington, DC.
- DOE, 2007a. Commercially Available LED Product Evaluation Reporting program: CALiPER 3, Washington, DC.
- DOE, 2007b. National Solar Technology Roadmap: Wafer-Silicon PV, Washington, DC.
- DSIRE, 2010. "State RPS Policies with Solar/DG Provisions." Database of State Incentives for Renewables and Efficiency. <http://www.dsireusa.org/> Accessed 18 December 2010.
- EIA, 2008. 2003 Commercial Buildings Energy Consumption Survey. Washington, D.C. Tables C13A, E5. <http://www.eia.doe.gov/emeu/cbecs/>
- EIA, 1992. "Energy Consumption Series: Lighting in Commercial Buildings." <http://tonto.eia.doe.gov/ftproot/consumption/0555921.pdf>.
- Energy Independence and Security Act (EISA), 2007. (P.L. 110-140). Section 301. "Efficiency Standards for Class A External Power Supplies."
- Energy Solutions, 2004. "Analysis of Standard Options for Under Cabinet Fluorescent Fixtures Attached to Office Furniture." For Pacific Gas and Electric Company.
- EPA, 2011. "ENERGY STAR Luminaires V1.1 Final Specification." http://www.energystar.gov/index.cfm?c=new_specs.luminaires
- EPA, 2007. "EGrid 2007: U.S. National Average Data for Year 2005." <http://www.epa.gov/cleanenergy/energy-resources/egrid/index.html>
- Erickson, R., 2001. Fundamentals of Power Electronics: Second Edition. Kluwer Academic Publishers: Norwell, MA.
- George, K., 2006. "DC Power Production, Delivery and Utilization." Electric Power Research Institute White Paper.
- Hammerstrom, D. J., 2007. "Ac versus DC distribution systems: Did we get it right?" in *IEEE Power Engineering Society General Meeting, 2007*. http://ieeexplore.ieee.org/xpl/freeabs_all.jsp?arnumber=4275896
- International Energy Agency (IEA), 2010. "Technology roadmap: Solar photovoltaic energy." www.iea.org/papers/2010/pv_roadmap.pdf
- IEEE, 2010. "IEEE Standard for a Universal Power Adapter for Mobile Devices: P1823." <http://standards.ieee.org/develop/project/1823.html>

- IEEE, 2009. "IEEE Standard for Information Technology: 802.3at-2009."
<http://standards.ieee.org/findstds/standard/802.3at-2009.html>
- Jancauskas, J. R. and Guthrie, R. L., 1995. "Elimination Of Direct Current Distribution Systems From New Generating Stations." In Nuclear Science Symposium and Medical Imaging Conference.
- Jennings, J. D., Rubinstein, F. M., DiBartolomeo, D., Blanc, S. L., 2000. "Comparison of Control Options in Private Offices in an Advanced Lighting Controls Testbed." LBNL-43096.
- Jimenez, A., 2005. "Photovoltaic Power Generation With Innovative Direct Current Applications: Feasibility and Example Site Evaluation." EPRI Technical Update# 1011533.
- Larson, E., 2003. *Devil in the White City*. Vintage Books: New York, NY.
- Mammano, B. 2007. "Improving Power Supply Efficiency – The Global Perspective." Texas Instruments Training Report: Topic 1.
<http://training.ti.com/courses/coursedescription.asp?iCSID=57748>
- Masters, G., 2004. *Renewable and Efficient Electric Power Systems*. Wiley-Interscience: Hoboken, NJ.
- Messenger, R. and Ventre, J., 2010. *Photovoltaics System Engineering: Third Edition*. CRC Press: Boca Raton, FL.
- Navigant Consulting, 2002. *Lighting Market Characterization, Vol 1*. IESNA Lighting Standard referenced in Table 4-1.
- NOAA, 2010. "Ranking of cities based on % annual possible sunshine in descending order from most to least average possible sunshine."
<http://www.ncdc.noaa.gov/oa/climate/online/ccd/pctposrank.txt>
- NREL, 2010. National Solar Radiation Database. http://rredc.nrel.gov/solar/old_data/nsrdb/
- Philips Lighting Company official, 2009. Personal communication. August 30.
- Pratt, A., Kumar, P., and Aldridge, T. V., 2007. "Evaluation of 400 V DC Distribution in Telco and Data Centers to Improve Energy Efficiency." In Telecommunications Energy Conference, Rome, Italy.
- Redwood Systems. 2010. "Two Case Studies Verifying Substantial Energy Savings From Redwood Lighting Controls." <http://redwoodsystems.com/solutions/white-papers/>
- Rocky Mountain Institute (RMI), 2010. "Achieving Low-Cost Solar PV: Industry Workshop Recommendations for Near-Term Balance of System Cost Reductions."
<http://rmi.org/rmi/SolarPVBOS>
- Salomonsson, D. and Sannino, A., 2007. "Low-voltage dc distribution system for commercial power systems with sensitive electronic loads." IEEE Transactions on Power Delivery. 22 (3), 1620-1627. <http://dx.doi.org/10.1109/TPWRD.2006.883024>
- Salomonsson, D. and Sannino, A., 2006. "Centralized ac/dc power conversion for electronic loads in a low-voltage dc power system." In Power Electronics Specialists Conference, 2006. Jeju, Korea. <http://dx.doi.org/10.1109/PESC.2006.1712251>
- Sannino, A., Postiglione, G., and Bollen, M., 2003. "Feasibility of a dc network for commercial facilities." In IEEE Transactions on Industry Applications 39 (5), 1499-1507.
<http://dx.doi.org/10.1109/TIA.2003.816517>
- Schavemaker, P., van der Sluis, L., 2008. *Electrical Power System Essentials*. Wiley & Sons, Ltd: London.
- Strachan, N. D., 2000. "Adoption and supply of a distributed energy technology." Carnegie Mellon University. Ph.D. Dissertation.

- Symanski, D. and Watkins, C., 2010. "380V Data Center at Duke Energy." Emerging Technology Summit. Presentation. Sacramento, CA. 9 Nov 2010.
<<http://www.emergealliance.org/Resources/Education.aspx>>
- Ton, M., Fortenbery, B., and Tschudi, W., 2008. "DC power for Improved Data Center Efficiency." Berkeley, CA.
- Tsao, J. Y., 2004. "Solid State Lighting: Lamps, Chips, and Materials for Tomorrow." *IEEE Circuits and Devices Magazine* 3.
- Turner, K., 2009. Negative rebound and disinvestment effects in response to an improvement in energy efficiency in the U.K. economy. *Energy Economics* 31, 648-666.
- Vorsatz, D., Shown, L., Koomey, J., Moezzi, M., Denver, A., and Atkinson, B., 1997. "Lighting Market Sourcebook for the U.S." Lawrence Berkeley National Laboratory.
<http://www.osti.gov/bridge/purl.cover.jsp?purl=/582218-ZfuTmH/webviewable/>
- Yamashita, T., Muroyama, S., Furubo, S., and Ohtsu, S., 1999. "270 V DC System – A Highly Efficient and Reliable Power Supply System for Both Telecom and Datacom Systems." In International Telecommunications Energy Conference, Copenhagen, Denmark.

2.6 Supporting Information

2.6.1 Lighting System, Power Electronics, and Wiring System Characteristics

The modeled lighting systems consist of a 1900-klm ambient lighting system with 366 recessed troffer fixtures with 5300 lm per fixture and a 330-klm task lighting system with 672 desk-level under cabinet fixtures with 490 lm per fixture., with technical and cost parameters shown in Table 2-2. A complete list of model parameters are provided in Section 2.6.2 of the SI. DC fluorescent ballasts and LED driver efficiencies were assumed to be equal to the respective AC ballast/driver efficiency divided by the efficiency of a rectifier. The DC lighting system is modeled as a circuit connecting the 277 V AC distribution system to a full-bridge rectifier with a non-isolated buck converter which produces 249 V DC output for each floor-level lighting system of the building. LED driver, centralized rectifier, and fluorescent ballast technical parameters and energy efficiency calculations are shown in Table 2-3. Centralized power supply costs depend primarily on output power rating, as shown in Table 2-4. We ignore issues of standby-mode power consumption for fluorescent ballasts because DOE (2011a) has determined that it only applies to dimming ballasts, which we do not consider. We also assume that LED drivers have zero off-state power consumption, which would meet the 2011 Energy Star standards for all LED lighting fixtures except those with motion- or photo-sensors or for use with multiple fixtures (EPA, 2011).

For the base case, annual lighting electricity intensity for the AC fluorescent lighting system is 2.3 – 4.9 (base case: 3.6) kWh/ft², assuming ambient lights operate between 2500 and 5600 hours/year and task lights operate between 1500 and 2500 hours/year. This lighting electricity intensity is just over half the average values for U.S. commercial office buildings as reported by the EIA (6.1 kWh/ft²) (1992), LBNL's Lighting Market Sourcebook (5.2 kWh/ft²) (Vorsatz et al.,

1997), and the 2003 Commercial Building Energy Consumption Survey (6.8 kWh/ft²) (EIA, 2008). This difference arises primarily from the assumption that an energy-conscious office building owner would design lighting fixtures to provide the IESNA minimum lumen requirement of 40 lumens/ft², while the EIA estimated that the average U.S. office has a mean illumination level of 45-91 lm/ft² (1992) which arguably means that it is overlit (Dau, 2003). Varying the amount of total lumens provided would change the absolute value of the estimated levelized annual cost in the Figure 2-3, but not the ordering from least to most expensive. In addition, the model excludes less efficient incandescent lighting in the base case lighting system because, given the voltages assumed, the efficiency of these resistive elements are not affected by the use of AC versus DC. In addition, because replacing incandescent lamps with fluorescent or LED lamps can lower levelized annual cost of lighting (DOE, 2011b; Azevedo, 2007), including incandescent lamps in the base case would artificially inflate the levelized cost benefits of DC circuits with an LED or fluorescent lighting system. We exclude issues of color quality in the present analysis.

Table 2-2: Base-case Fluorescent and LED Lighting System Parameters

	<u>AC FL</u>		<u>DC FL</u>		<u>AC LED</u>		<u>DC LED</u>	
	<i>Ambient</i>	<i>Task</i>	<i>Ambient</i>	<i>Task</i>	<i>Ambient</i>	<i>Task</i>	<i>Ambient</i>	<i>Task</i>
FL Lamp Cost: \$/fixture		1.5-		1.5-				
LED Lamp Cost:	11-27	2.5	11-27	2.5				
2010\$/klm					86-116		86-116	
Lamp Efficacy (lm/W)	86	78	86	78	125-169		125-169	
Fixture Efficacy (lm/W)	53	24	56	25	99	92	114	105
Fixture Efficiency (%)	72%	37%	72%	37%	87%	80%	87%	80%
Calc: System Power (W)	99	20	94	19	53	5	46	5

Notes: The number of lighting fixtures and lighting system power are calculated from building geometry and IESNA lumen requirements of 40 lm/ft² for office buildings (Navigant Consulting, 2002), holding fixture lumens constant across scenarios. For details see Section 2.6.2 of the Supporting Information (SI). Cost per fixture obtained from Grainger.com (2010). Fluorescent lamp efficacies from Navigant Consulting (2002). LED ambient fixture efficiency and fluorescent fixture efficiencies are from DOE (2011b, 2007a). LED task fixture efficiency is from DOE (2011b). LED fixtures have higher efficiencies than their fluorescent counterparts due to the directional nature of LED lumen output.

Table 2-3: Lighting System Power Supply Parameters

	<u>AC-DC Central Power Supply</u>		<u>DC-DC Load Power Supply</u>		<u>Fluorescent Ballasts</u>	
	<i>FL</i>	<i>LED</i>	<i>LED Ambient</i>	<i>LED Task</i>	<i>AC</i>	<i>DC</i>
Converter Type	Buck	Buck				
V _{in} (V)	277	277	242	242	277	242
V _{out} (V)	242	242				
Calc: Efficiency (%)	93 ± 1 ^a %	93 ± 1 ^a %	84-92 ^b %	84-92 ^b %	85-109 ^c %	91-112 ^d
Calc: L (H)	8x 10 ⁻⁷	2x 10 ⁻⁶				
Calc: C (F)	10x 10 ⁻⁸	7.x 10 ⁻⁸				
Calc: (R _{ON} , R _L , R _D) /Rload (%)	1%	1%				
Calc: Rload (Ohm)	1 ± 0.1	2 ± 0.3				

^aAC-DC central power supply efficiencies are calculated assuming a buck converter topology, see Table 2-4 for costs and (Erickson, 2001) for efficiency analysis.

^bAC LED driver efficiencies are from R&D targets in (DOE, 2011b).

^cBallast Efficiency is defined as the ratio of rated lamp power over lamp and ballast power consumption. If the ballast is designed to run lamps at less than their rated power, the ballast's nominal efficiency will be greater than 100%, yet the lamp will produce fewer lumens than if run at rated power. Ballast efficiency, together with ballast factor, determines the light output and power consumption of the fluorescent lamp and ballast system. AC fluorescent ballast efficiencies are from GE, Philips, and Osram Sylvania lamp catalogs.

^dDC fluorescent ballast and DC driver efficiencies are assumed to be equal to AC ballast/driver efficiency divided by rectifier efficiencies of 93-97% from (Pratt et al., 2007).

Output Power Rating (W)	Cost (\$/W)
0 – 50	0.10
51 – 150	0.34
150 – 250	0.18
250 – 500	0.17
500 – 1,000	0.20
1,000 – 50,000	0.17

Source: Philips, 2009

The wiring system is sized to meet lighting system current requirements, subject to copper conductor current limits and National Energy Code maximum voltage drop limits of 5% per string. These two constraints on the wiring system limit maximum wire lengths. Since we are modeling a new commercial building, the LAC calculations include wiring costs. Cables that

provide a direct connection from the central power supply on each floor to the AC grid are assumed to be common to all cases and are not included in the model. We assume four circuit breakers per floor for the ambient lighting system; these costs were explicitly included in the LAC calculations, with prices obtained from manufacturer datasheets (see details in Section 2.6.2 of the Supporting Information). Circuit breakers (switches) for the task lighting systems are assumed to be integrated in the fixture design and are not explicitly included in the model.

While electrical safety is not the focus of this study, higher voltage DC wiring poses a greater arc hazard than AC circuits and require specialized circuit breakers and protection (Salomonsson and Sannino, 2007). AC circuit breakers function by opening the circuit, which typically forms an arc that is extinguished when the voltage waveform passes through zero. Arcs in high voltage (>50 V) DC wiring systems can occur through a loose wiring connection or damaged insulation between cables of different polarity or between an electrical circuit and ground (Dargatz, 2009). DC wiring can cause arcing even at currents under the threshold at which the circuit protection operates. Thus, some DC wiring may need additional arc-quenching insulation and fault-detection and special signage for first-responders and other emergency service personnel. These additional costs imposed by safety considerations for DC wiring are excluded in our analysis.

2.6.2 Engineering Design and Economic Model Inputs and Outputs

Parameter	Symbol	Unit	Description/Equation/Reference	Minimum/ Nominal Value	Maximum Value
<i>Engineering Model</i>					
<i>Building Input Parameters</i>					
Office Width	w	ft	Office building width	100	
Office Breadth	b	ft	Office building breadth	120	
Office Height	h	ft	Office building height	8	
Number of Floors	nf		Number of floors	4	
Square feet per person	sqft _{pp}	ft ²	Square feet per office occupant, average value from http://www.officespace.com/SpaceCalc.cfm	75	
Cube Rows	cr		Number of cubicle rows	6	
Desk space	dk	ft ²	Desk space	12	
<i>Building Output Parameters</i>					
Floorspace	fs	ft ²	$fs = w * b * nf$	48,000	
Number of occupants	ocp		$ocp = fs / sqft_{pp}$	672	
Cube Columns	cc		$cc = ocp / (4 * nf * cr)$, rounded	7	
Task light space	tls	ft ²	$tls = dk * cc * cr * nf * 4$	8064	
<i>Lighting System Input Parameters</i>					
Lumen Requirement	lmft	lm/ft ²	Navigant Consulting, 2002	40	
Ambient Lighting Annual Operating Hours	aaoh	hrs	Annual operating hours for ambient lighting from Navigant Consulting (2002).	2500	5600
Task lighting Annual Operating Hours	taoh	hrs	Annual operating hours for task lighting from Energy Solutions (2004).	1500	2500
Fluorescent (FL) Ballast Factor	Bf		From GE, Philips, and Osram Sylvania, Inc. (OSI) Lamp Catalogs	0.84	0.92

Parameter	Symbol	Unit	Description/Equation/Reference	Minimum/ Nominal Value	Maximum Value
T8 FL Efficacy	t8efc	lm/W	From GE, Philips, and OSI Lamp Catalogs	80	92
FL Lamps per Ambient Fixture	flpaf			3	
FL Lamps per Task Fixture	flptf			1	
LED Lamps per Ambient Fixture	lpaf			12	
LED Lamps per Task Fixture	lptf			1	
T8 Watts	t8w	W		32	
T12 FL Efficacy	t12efc	lm/W	From GE, Philips, and OSI Lamp Catalogs	70	86
T8 FL lifetime	t8lf	hrs	T8 Fluorescent lamp lifetime in hours, From GE, Philips, and OSI Lamp Catalogs	16000	24000
T12 FL lifetime	t12lf	hrs	T12 Fluorescent lamp lifetime in hours, From GE, Philips, and OSI Lamp Catalogs	16000	24000
T8 FL Ballast lifetime	t8blf	hrs	T8 Fluorescent ballast lifetime in hours, From GE, Philips, and OSI Lamp Catalogs	32000	48000
T12 FL Ballast lifetime	t12blf	hrs	T12 Fluorescent ballast lifetime in hours, From GE, Philips, and OSI Lamp Catalogs	32000	48000
Ac T8 FL Ballast Efficiency	acT8beff	%	Ballast Efficiency equals the ratio of rated lamp power over lamp-and-ballast power consumption. From lamp catalogs	0.85	1.09
AC T12 FL Ballast Efficiency	acT12beff	%	Ballast Efficiency equals the ratio of rated lamp power over lamp-and-ballast power consumption. From lamp catalogs	0.9	0.98

Parameter	Symbol	Unit	Description/Equation/Reference	Minimum/ Nominal Value	Maximum Value
FL ambient fixture efficiency	$afeff_{fl}$	%	DOE, 2007a	0.65	0.8
FL task fixture efficiency	$tfeff_{fl}$	%	DOE, 2007a	0.3	0.5
LED lifetime	ledLf	hrs	DOE, 2011b	40000	60000
LED driver lifetime	ledDrvL	hrs	DOE, 2011b	40000	60000
LED ambient fixture efficiency	$afeff_{led}$	%	Average (.87) from DOE, 2007a	0.77	0.97
LED tasklight fixture efficiency	$tfeff_{led}$	%	Average (.80) from DOE, 2011b	0.70	0.90
Maximum LED Efficacy	$maxEfc_{le}$	lm/W	Tsao, 2004	400	
Maximum FL Efficacy	$maxEfc_{fl}$	Lm/W	Derived from Tsao (2004), FL are 25% efficient at 85 lm/W, max efficacy = 4*85 lm/W	340	
<i>Lighting System Output Parameters</i>					
Ambient LED lamp watts	alw	W	$L_{paf}/(n_{af} * ledEfc * thermEff * l_{paf} * afeff_{led})$; LED efficacy and thermal efficiency R&D targets in Table 2-1	Varies	
Ambient fixture watts	$afw_{fl/led}$	W	$(l_{paf} \text{ or } fl_{paf}) * (t8w) / (t8beff \text{ or } drvEff)$; driver efficiency R&D targets in Table 2-1	Varies	
Ambient fixture efficacy	$afec_{fl/led}$	lm/W	$thermEff * (t8- \text{ or } led-Efc) * (afeff_{fl/led}) * (ac/dc, T8beff \text{ or } ledDrvEff) * (t8blf)$; thermal efficiency R&D targets in Table 2-1	Varies	
Number of ambient fixtures	naf		$round(lmft * fs / (afw * afec))$	360	
Tasklight LED lamp watts	tlw	W	$L_{paf} / (n_{tf} * ledEfc * thermEff * l_{ptf} * tfeff_{led})$; LED efficacy and thermal efficiency R&D targets in Table 2-1	Varies	

Parameter	Symbol	Unit	Description/Equation/Reference	Minimum/ Nominal Value	Maximum Value
Tasklight fixture watts	$tfw_{fl/led}$	W	$lmft*dk/tfefc$	Varies	
Tasklight fixture efficacy	$tfefc_{fl/led}$	lm/W	$thermEff*(t12- or led-Efc)$ $*tfeff_{fl/led}*(ac/dc, t12beff or$ $drvEff)*(t12blf)$; thermal efficiency R&D targets in Table 2-1	Varies	
Number of tasklight fixtures	ntf		$ntf=cc*cr*nf*4$	672	
<i>Central Power Supply Input Parameters</i>					
Input Voltage	V_g	V_{ac}		277	
Output Voltage	V	V_{dc}		48, 60, 250	
Diode forward Voltage drop	V_D	V		0.35	1.7
Switching period	T_s	sec		.0001	
Central power supply lifetime	psLf	hrs	http://www.testequity.com/products/1691/	30000	40000
<i>Central Power Supply Internal Parameters</i>					
Load resistance	R_{load}	W	$R_{load} = V/I$	Varies	
Inductor resistance	R_L	W	$R_L = 0.01*R_{load}$	Varies	
Switch transistor on resistance	R_{on}	W	$R_{on} = 0.01*R_{load}$	Varies	
Diode resistance	R_D	W	$R_D = 0.01*R_{load}$	Varies	
Voltage ripple	ΔV	V	$\Delta V = 0.05*V$;	Varies	
Duty Cycle	D		$D = (V*(R_L + R_D + R_{load}) +$ $V_D*R_{load})/(R_{load}*(V_g + V_D) + V*(R_D -$ $R_{on}))$	Varies	
D-prime	D'		$D' = (1-D)$	Varies	
Inductor current	I_L	A	$I_L = (D*V_g - D'*V_D)/(R_L + D*R_{on} + R_{load})$	Varies	
Capacitor	C	F	$C = (D*T_s*(R_{load}*I_L - V)/(2*DV*R_{load}))$;	Varies	
Inductor	L	H	$L = (D*T_s*(V_g - I_L*(R_{on} + R_L) - V)/(2*D*I_L))$;	Varies	

Parameter	Symbol	Unit	Description/Equation/Reference	Minimum/ Nominal Value	Maximum Value
<i>Central Power Supply Output Parameter</i>					
Converter Efficiency	PS η	%	$\eta = (1 - D' * V_D / (D * V_g)) / (1 + (R_L + D * R_{on} + D' * R_D) / R_{load})$	93%	
<i>PV, Wiring, Electrical System Input Parameters</i>					
AC Operating Voltage	acOpV	V _{ac}		277	
DC Operating Voltage	dcOpV	V _{dc}		249	
Wire Installation Time	wit	hrs/ft	http://www.turtlesoft.com/construction-costs/Electric-Rough/Romex_6_3.htm	0.026 ; (1hr/38 ft)	
Wire life	wlf	yrs		25	
Inverter Efficiency	invEff	%	George (2006).	0.87	.94
Inverter Lifetime	invLife	yrs		10	
Rectifier Efficiency	rectEff	%	Pratt et al. (2007).	0.93	.97
Battery Lifetime	battLife	yrs		10	
Battery Charge Efficiency	battChEf f	%	Messenger and Ventre, 2010	95	
Battery Discharge Efficiency	battDEff	%	Messenger and Ventre, 2010	95	
Battery Cost	battCost	\$/Ah	Grainger.com products, assuming 1.5% cost decline per year. See Table 2-1	varies	
<i>PV, Wiring, Electrical System Internal Parameters</i>					
Ambient Fixture Current	afc	A	afw/(acOpV or dcOpV)	Varies	
Ambient Wire Current Rating	awc	A	Min AWG table current s.t. (AWG table current \geq afc) & awvd \leq 0.05*(acOpV or dcOpV)	12	
Ambient Wire Resistance Rating	awr	$\Omega/1000$ f t	Wire resistance corresponding to cable with current rating awc in AWG Table	2.53	
Ambient Wire Voltage Drop	awvd	V	awl*afc*awr/1000	Varies	

Parameter	Symbol	Unit	Description/Equation/Reference	Minimum/ Nominal Value	Maximum Value
Ambient Wire Gauge	afwg		Wire gauge corresponding to cable with current rating awc in AWG Table	14	
Tasklight Fixture Current	Tfc	A	tfw/(acOpV or dcOpV)	Varies	
Tasklight Wire Current Rating	twc	A	Min AWG table current s.t. (AWG table current \geq tfc) & twvd \leq 0.05*(acOpV or dcOpV))	12	
Tasklight Wire Resistance Rating	twr	$\Omega/1000$ f t	Wire resistance corresponding to cable with current rating twc in AWG Table	2.53	
Tasklight Wire Voltage Drop	twvd	V	twl*afc*awr/1000	Varies	
Tasklight Wire Gauge	tfwg		Wire gauge corresponding to cable with current rating awc in AWG Table	14	
Hourly Insolation by month	solRad	W/m ²	Masters, G. (2004)	Varies	
<i>PV, Wiring, Electrical System Output Parameters</i>					
Ambient fixture wire length	Awl	ft	$(w*cr/4+b/2)*4*nf$	Varies	
Task fixture wire length	Twl	ft	Assumes central circuit box and radial cables to each desk with varying length	Varies	
Lighting Load	LkW	kW	if DC, $(naf*afw_{fl/led} + ntf*tfw_{fl/led})/PS\eta$, else $naf*afw_{fl/led} + ntf*tfw_{fl/led}$	Varies	
PV Panel size	pvkW	kW	See Equation 4.	Varies	
PV Electricity Output	pvkWh	kWh	$pvkW*(.97*.96*invEff*(1-0.005*(celltemp-25)))*solRad/1000$, calculated hourly, aggregated to daily averages per month	Varies	
Grid Electricity Consumption	gridkWh	kWh	For each month, hourly grid kWh for the avg day = $naf*afw_{fl/led} - hrlyPVkWh$, aggregated for aaoH hours/year + $ntf*atoh*tfw_{fl/led}$ (tasklight electricity consumption), if excess PV electricity,	Varies	

Parameter	Symbol	Unit	Description/Equation/Reference	Minimum/ Nominal Value	Maximum Value
assume used by exogenous loads					
<i>Economic Model Inputs</i>					
<i>Lighting System Cost Input Parameters</i>					
T8 Lamp cost	t8c	\$/3-lamps	Assume ambient fixtures use three 4-foot t8 lamps in a recessed troffer fixture. Costs from Grainger.com	3.75	9
Fluorescent Ambient Fixture Cost	afc _f	\$/fix	Costs from Grainger.com	17	97
T12 Lamp cost	t12c	\$/lamp	Assume tasklights use one 2-foot t12 lamp in an undercabinet fixture	1.5	2.5
Fluorescent Tasklight fixture cost	tfc _f	\$/fixture	Costs from Grainger.com	23	43
AC T8 ballast cost	t8balc	\$/ballast	Costs from Grainger.com	11	24
AC T12 ballast cost	t12balc	\$/ballast	Costs from Grainger.com	5	9
LED Ambient Fixture Cost	afc _{led}	\$/fixture	Costs from Grainger.com	19	99
LED Tasklight Fixture cost	tfc _{led}	\$/fixture	Costs from Grainger.com	31	46
Technician Level I Labor Rate	tech1	\$/hr		10	20
Technician Level II Labor Rate	tech2	\$/hr		40	68
Fluorescent Ballast Installation Time	bInst	hr		0.5	
Lamp Installation Time	lInst	hr		0.25	
Luminaire Installation Time	lumInst	hr		0.5	
LED Driver Installation time	dInst	hr		0.5	
<i>Lighting System Cost Output Parameters</i>					
Luminaire Cost, lamp	(a/t)Lum C-1	\$	Same calculations for ambient or task lighting. For LEDs:	Varies	

Parameter	Symbol	Unit	Description/Equation/Reference	Minimum/ Nominal Value	Maximum Value
Luminaire Cost, fixture	LumC- fx	\$	$\text{costPerKlm} * \text{ledEfc} * (\text{alw} * \text{lpaf} * \text{naf}$ or $\text{tlw} * \text{lptf} * \text{ntf}) / 1000$; For FL: $\text{flpaf} * \text{t8c}$ or $\text{flptf} * \text{t12c}$ $\text{naf} * \text{afc}_{\text{fl/led}}$ or $\text{ntf} * \text{tfc}_{\text{fl/led}}$	Varies	
Luminaire Cost, ballast or driver	LumC- lps	\$	For FL: $\text{naf} * \text{t8bale}$ or $\text{ntf} * \text{t12bale}$; For LEDs: $(\text{naf} * \text{afw}_{\text{led}}$ or $\text{ntf} * \text{tfw}_{\text{led}}) * \text{DrvCostPerW}$; Driver cost per Watt estimates in Table 2-4.	Varies	
Luminaire Cost, installation	LumC- in	\$	$\text{Tech2} * \text{lumInst}$	Varies	
Luminaire Cost, annual maintenance	LumC- m	\$	$\text{lInst} * \text{tech1} * (\text{aaoh} / \text{t8lf}$ or $\text{taoh} / \text{t12lf}$ or $\text{aaoh} / \text{ledLf}$ or $\text{taoh} / \text{ledLf}) + \text{tech2} * (\text{aaoh} / \text{t8blf} * \text{bInst}$ or $\text{taoh} / \text{t12blf} * \text{bInst}$ or $\text{aaoh} / \text{ledDrvLf} * \text{dInst}$ or $\text{taoh} / \text{ledDrvLf} * \text{dInst})$	Varies	
<i>Central Power Supply Cost Input Parameter</i>					
Power Supply Installation Time	psInst	hrs		1	
<i>Central Power Supply Cost Internal Parameter</i>					
Output Power	Pout	W	LkW/nf	Varies	
<i>Central Power Supply Cost Output Parameter</i>					
Central Power Supply Cost, equipment	psC-eq	\$	$\text{psCostPerW} * \text{Pout}$, See Section 2.6.1 for power supply costs	Varies	
Central Power Supply Cost, installation	psC-in	\$	$\text{tech2} * \text{psInst}$	Varies	
Central Power Supply Cost, maintenance	psC-m	\$	$\text{Tech2} * \text{psInst} * \text{aaoh} / \text{psLf}$	Varies	

Parameter	Symbol	Unit	Description/Equation/Reference	Minimum/ Nominal Value	Maximum Value
<i>PV, Wiring, Electrical System Cost Input Parameters</i>					
Inverter Cost	invC	\$/W _p	RMI, 2010	Varies	
PV Balance of Plant Cost	bop	\$/W _p	RMI, 2010; Curtright et al., 2008	Varies	
250 V DC Switch Cost	Sw250	\$/switch	http://www.abb.com/product/seitp329/19130a55833d8efdc1256e89004019e9.aspx ; half list price; assume 4 switches per floor, task lamp switches built into fixture	115	155
48 V DC Switch Cost	Sw48	\$/switch	http://www.abb.com/product/seitp329/19130a55833d8efdc1256e89004019e9.aspx ; list price	10	13
60 V DC Switch Cost	Sw60	\$/switch	http://www.abb.com/product/seitp329/19130a55833d8efdc1256e89004019e9.aspx ; half list price	59	80
277 V AC Switch Cost	Sw277	\$/switch	http://www.drillspot.com/products/43243/Maple_Chase_ET1100_Electronic_Light_Switch	49	67
<i>PV, Wiring, Electrical System Cost Output Parameters</i>					
ambWireCost , equip	aWireC- eq		wire cost/ft*awl + nf*4*(sw48 or sw60 or sw250 or sw277)	Varies	
ambWireCost,installation	aWireC- in		awl*wit*tech2	Varies	
TaskWireCost , equip	tWireC- eq		wire cost/ft*twl	Varies	
TaskWireCost,installation	tWireC- in		twl*wit*tech2	Varies	
PV Panel Costs	pvC	\$	1000*pvkW*(bop +pvPanelCostPerW); PV panel costs in Table 2-1	Varies	
<i>Economic Input Parameters</i>					
Discount Rate	<i>i</i>			0.12	

Parameter	Symbol	Unit	Description/Equation/Reference	Minimum/ Nominal Value	Maximum Value
Time Period	τ	Years		20	
Electricity Price	E	\$/kWh		0.1	
<i>Economic Output Parameters</i>					
Cap			aLumC + LumC + aWireC+ tWireC + psC	Varies	
pv cap			PV panel +bop costs	Varies	
Lac			See equations 1-2	Varies	
Npv			See equation 3	Varies	
<i>Environmental Input Parameters</i>					
Electricity CO ₂ Intensity	eCO ₂	Ton CO ₂ /kW h	EPA, 2007.	0.001	
Electricity SO ₂ Intensity	eSO ₂	Ton SO ₂ /kW h	EPA, 2007.	2.63*10 ⁻⁶	
Electricity NO _x Intensity	eNO _x	Ton NO _x /kW h	EPA, 2007.	9.68*10 ⁻⁷	
<i>Environmental Output Parameters</i>					
Cost of CO ₂ Conserved	CO ₂ C	\$/ton CO ₂	$(lac_{scenario} - lac_{acfl}) / (CO2_{acfl} - CO2_{scenario})$	Varies	
Cost of SO ₂ Conserved	SO ₂ C	\$/ton SO ₂	$(lac_{scenario} - lac_{acfl}) / (CO2_{acfl} - SO2_{scenario})$	Varies	
Cost of NO _x Conserved	NO _x C	\$/ton NO _x	$(lac_{scenario} - lac_{acfl}) / (CO2_{acfl} - NOx_{scenario})$	Varies	
<i>Monte Carlo Parameter</i>					
n			Number of runs in simulation	1000	

Chapter 3: Estimating Direct and Indirect Rebound Effects for U.S. Households with Input-Output Analysisⁱⁱ

Abstract

This study develops a model of the indirect rebound effect, given a direct rebound estimate, in terms of primary energy, CO₂e, NO_x, and SO₂ emissions for a simulated energy efficiency investment that either reduces electricity, natural gas, or gasoline expenditures for the average U.S. household. We model both the substitution and income effects of the indirect rebound effect, which provide similar estimates as using proportional spending or income effect re-spending assumptions, unless there is a large direct rebound. We apply the model using a 2002 environmentally-extended input-output model and the 2004 Consumer Expenditure Survey (in 2002\$) for the U.S., and find an indirect rebound of 5-15% in primary energy and CO₂e emissions, assuming a 10% direct rebound, and depending on the fuel saved with efficiency and household income. The indirect rebound can be as high as 30-40% in NO_x or SO₂ emissions, for efficiency in natural gas services. As the U.S. electric grid becomes less-carbon intensive, or in households with large transportation demands, the indirect rebound effect will be larger. Even in extreme cases, there is limited evidence for backfire, or a rebound effect greater than 100%. Our model does not account for household budget savings or the possible higher capital costs for efficiency, both of which may lead to lower indirect rebound effects than the results in this paper. We conclude that energy efficiency policies still provide environmental benefits after accounting for rebound effects.

ⁱⁱ A paper based on this chapter is under review at *Ecological Economics*. Authors: Brinda A. Thomas and Ines L. Azevedo.

3.1 Motivation and Literature Review

Many policymakers support energy efficiency policies as a cost-effective method to reduce energy consumption, criteria air pollutant emissions, and greenhouse gas emissions (GHG, measured in CO₂-equivalents) to mitigate climate change, while providing economical energy services (e.g., lighting, heating, transportation). The International Energy Agency (IEA) projects that by 2030, one half of the lowest-cost GHG abatement options in Organization for Economic Cooperation and Development (OECD) countries will come from energy efficiency, largely in end use technologies (IEA, 2010). In the U.S., the absence of a political consensus for a national climate change policy has led to the promotion of energy efficiency policies to maintain cheap energy services, to create jobs, and to promote sustainable energy systems. Currently, 29 states have Energy Efficiency Resources Standards (EERS) or voluntary efficiency goals in place (ACEEE, 2011a) and the federal American Recovery and Reinvestment Act also included a \$17 billion investment in energy efficiency programs (ACEEE, 2011b). However, there is a well-established gap between the technical, economic, and feasible potential for energy efficiency because of market failures, market barriers, stock turnover issues, behavioral patterns (Jaffe and Stavins, 1994; Howarth and Sanstad, 1995; Sanstad et al., 1995; Sorrell et al., 2004; Gillingham et al., 2009; Azevedo, 2009; Greene, 2011), and the differences between laboratory and real-world conditions (Vine et al., 1994), which is called “shortfall” (Sorrell et al., 2009). In addition, there is a debate among scholars and policymakers about whether energy efficiency investments are able to lower energy consumption due to changes in consumer behavior in what is known as the rebound effect (R), which accounts for a gap between engineering assessments of potential energy savings, PES, after shortfall factors have been accounted for, and actual energy savings, AES (Sommerville, 2007; Guerra and Sancho, 2010), where

$$R = 1 - \frac{AES}{PES} \quad 3-1$$

Given the heavy reliance on energy efficiency in many countries to meet long-term GHG abatement and other energy policy goals, it is important to understand the extent of the rebound effect.

The rebound effect, decomposed into direct, indirect, and economy-wide components, describes the change in energy demand following an efficiency investment due to economic and other behavioral patterns. The *direct rebound effect* describes the increase in the demand for energy services due to the lower price of energy services with an efficiency investment (Khazzoom, 1980; Greening et al., 2000; Berkhout, 2000; Sorrell and Dimitropoulos, 2008), e.g. increasing the number of miles driven per year with the purchase of a more fuel-efficient vehicle because the gasoline cost per mile driven has decreased. The *indirect rebound effect* describes the respending of energy cost savings on other goods (Greening et al., 2000; Berkhout, 2000; Schipper and Grubb, 2000; Binswager, 2001; Chalkely et al., 2001; Druckman et al., 2011), e.g. spending gasoline cost savings on an overseas vacation, which in turn requires additional energy and associate emissions for its provision. The *economy-wide rebound effect* includes both the direct and indirect effects as well as macroeconomic effects such as the energy consumption induced by a lower market price for energy, changes in economic structure, economic-competitiveness (Brookes, 1990, 2000; Howarth, 1997; Saunders, 1992, 1998, 2000, 2010; Allan et al., 2007; Wei, 2010), investment and disinvestment, and labor market changes resulting from energy efficiency investments (Turner, 2009). Van den Bergh (2011) provides a comprehensive taxonomy of 14 mechanisms for the energy efficiency rebound effect.

The rebound effect can be measured in the short-run, including energy service consumption changes, and in the long-run, incorporating changes in the cost and availability of the capital stock. Most studies of the rebound effect focus on changes in the marginal price of energy services, and disregard the income constraints imposed by the possibly higher investment costs of an energy efficient technology. Researchers who investigate how capital costs affect the rebound effect find, not surprisingly, that the higher capital cost of efficient technologies may lower the extent of the rebound effect (Henly et al., 1987; Wirl, 1997; Mizobuchi, 2008; Chitnis, 2012; Nassen and Holmberg, 2009) although methods for incorporation of capital costs in energy demand and energy service demand models are an open area of research. In this chapter we develop an analytical model of the direct and indirect rebound effect, excluding capital costs and household budget savings, from a static, fixed-price, general equilibrium perspective, by integrating methods from industrial ecology with microeconomics. Dynamic, time and price-varying, economy-wide rebound effects are outside the scope of this chapter.

There has been considerable empirical research on the direct rebound effect in the residential sector, measured in terms of various energy price elasticities (Sorrell and Dimitropoulos, 2008) and using a variety of methods (Sorrell et al., 2007). Scholars have found that the direct rebound effect varies by region with generally higher rebound effects found in developing countries (Roy, 2000; Allan et al., 2007; Wang et al., 2012; Davis et al., 2012), and in low-income households in developed nations (Hirst, 1985; Small and van Dender, 2005, 2007; Greene, 2012; Gillingham, 2011; Frondel et al., 2011) where the demand for energy services is furthest from saturation. Direct rebound effects also depend on the energy service considered, with heating and cooling more prone to rebound effects than refrigeration, clothes washing, and drying (Greening et al., 2000; Sorrell et al., 2007; Schipper and Grubb, 2000; Davis, 2008; Davis et al., 2012).

“Consensus” estimates of the direct rebound effect depend on the methodology used.

Scholars comparing household billing records before and after utility-sponsored energy efficiency program find that behavioral changes such as turning up the thermostat for increasing comfort lead to direct rebound estimates as low as 1-3% (Dinan and Trumble, 1989) to a level of 10-15% (Hirst, 1985). Other scholars use simplified engineering models of building efficiency with econometric analysis of household billing data to measure direct rebound effects in terms of efficiency elasticities of 1-3% for electric space heating (Schwartz and Taylor, 1995), or in terms of energy service price elasticities of 2-13% for electric cooling and 8-12% for electric heating (Dubin et al., 1986). Davis (2008) measures energy price elasticities of 6% for electricity and water use in residential clothes washers in a field trial, by controlling for self-selection of efficient appliance purchases, which tends to bias upward energy price elasticity-based measures of the direct rebound effect. In the transportation sector, with greater availability of data on energy service demand (vehicle-miles traveled) and vehicle efficiency (fuel economy), scholars have found direct rebound estimates in the 3-20% range (Haughton and Sarkar, 1996; Small and van Dender, 2007; Gillingham, 2011; Greene, 2012; Schmiek, 1996).

There is a larger body of literature on measuring direct rebound effects in terms of energy price elasticities, without accounting for self-selection issues, which range from 4-87% (Klein, 1985; Hseuh and Gerner, 1993; Berkhout et al., 2000; Greening et al. 2000; Dubin and McFadden, 1984; Frondel, 2007). However, energy price elasticities are an overestimate of the direct rebound effect because of the correlation between rising energy prices and investments in energy efficiency (Hanly et al., 2002; Henly et al., 1988). In particular, energy price elasticities measured without controlling for energy efficiency improvements over time will suffer from an omitted variable bias which will bias upward the energy price elasticity estimate (Small and van

Dender, 2007). For a selected review of electricity service and transportation direct rebound estimates using the preferred efficiency elasticity or energy service price elasticity approach, see Table 3-2 in Section 3.7 the Supporting Information (SI).

The indirect rebound effect has been studied through complementary but distinct methods in the energy economics and industrial ecology literatures, summarized in Table 3-3 in the SI. Energy economists tend to jointly measure the direct and indirect rebound effects using a system of demand models for energy and other goods, such as the Almost Ideal Demand System (AIDS) model, pioneered by Deaton and Muellbauer (1980). However, most prior studies applying the AIDS model to simulate direct and indirect rebound effects (Brannlund et al, 2007; Mizobuchi, 2008; Wang et al., 2012) suffer from three weaknesses. First, they use energy price elasticities that overestimate the direct rebound effect. Kratena and Wuger (2010), is an exception, in that they develop indices of appliance efficiency to estimate direct and indirect rebound effects by energy service price elasticities within an AIDS model framework for in the U.S., but their measured income elasticities are largely negative in some sectors, which is inconsistent with general studies of U.S. consumer demand using AIDS and other demand systems approaches (Taylor and Houthakker, 2010). Second, these prior AIDS model studies of direct and indirect rebound effects have not included time trends or other corrections for non-stationary technology change or other changes over time, and without doing do, their elasticity estimates may violate the properties of elasticities from microeconomic consumer demand theory, as Deaton and Muelbauer (1980) noted in their seminal paper introducing the model. Hunt and Ryan (2011, 2012) argue that incorporation of time trends, lagged price variables, or other measures of technological change are important to estimate direct and indirect rebound effects with the AIDS model in an energy services framework. Third, these studies from the energy economics literature tend to

include only the combustion emissions, called scope 1 emissions, and/or purchased electricity emissions, called scope 2 emissions, in their indirect rebound estimates.

Another important source of emissions are upstream, supply-chain emissions required to extract materials, manufacture, and distribute goods and services, called scope 3 emissions, which are extensively studied in the industrial ecology literature on household and national carbon footprints (CF) or environmental footprints. These studies use environmentally extended input-output (EEIO) analysis (Leontief, 1970) and show that over half of household CF can be attributed to non-energy goods and services for the case of Sweden (Carlsson-Kanyama et al., 2005), the U.S. (Weber and Matthews, 2008), the U.K. (Druckman and Jackson, 2009), and 73 other nations, based on evidence from a multi-regional trade-linked analysis (Hertwich and Peters, 2009). Industrial ecology studies tend to focus on aspects of the indirect rebound effect related to various measures of household spending patterns and the change in scope 1 (combustion), scope 2 (purchased electricity), and scope 3 (supply chain) emissions, as measured from an EEIO model. Some industrial ecology studies assume that household cost savings will be re-spent in proportion to current spending patterns, for broadly defined sustainability measures, such as “greener” diets or conservation activities, including energy efficiency, (Lenzen and Dey, 2002; Takase et al., 2005), or reducing office work by teleworking (Kitou et al., 2003). Goedkoop et al. (1999) argue that marginal spending patterns are more important than proportional or average spending patterns, and Thiesen et al (2008) attempt to quantify these using slopes of spending patterns between one income group to the next higher income group. Other studies directly measure marginal spending patterns using income elasticities from consumption data and couple them with an EEIO model to measure indirect rebound effects from conservation or efficiency activities (Alfredsson, 2004; Girod and de Haan, 2010; Druckman et al., 2011; Murray, 2011; Chitnis et al.,

2012). However, these studies do not include a direct rebound effect, which is not applicable for non-efficiency activities, and so cannot be compared with energy economics studies of the indirect rebound effect. Freire-Gonzalez (2011) does include the direct rebound effect with income elasticities and an EEIO model to study the direct and indirect rebound effect in Catalonia. However, he overestimates the direct rebound effect by using energy price elasticities. Nassen and Holmberg (2009) is the study most similar to our approach, which uses energy service price elasticities with income elasticities and scope 1-3 emissions from EEIO model for Sweden.

In this chapter, we extend the Nassen and Holmberg approach for the case of the U.S. by analyzing the direct and indirect rebound effects in terms of substitution and income effects, and measured by the cross-price elasticity of the demand for other goods with respect to the price of energy services, using principles from microeconomic consumer demand theory. As in Nassen and Holmberg (2009), we take direct rebound estimates from the literature, and focus on the differences in indirect rebound estimates for energy services provided by electricity, natural gas, or gasoline. Our innovation is that we use the direct rebound parameter to construct cross-price elasticities that are consistent with the budget constraint from consumer demand theory, and flexible enough to allow for rebound effects greater than 100% (called backfire). These constructed cross-price elasticities are a proxy for more flexible estimates from an AIDS model, which does not place any restrictions on the extent of constant-utility or compensated cross-price elasticities beyond properties of elasticities from consumer demand theory. We compare indirect rebound results using just scope 1 (combustion emissions) for natural gas or gasoline services or scope 2 emissions from electricity services, with results using the full scope 3 supply chain emissions from an EEIO model to inform energy economists of the importance of supply chain effects for indirect rebound estimates. In addition, we compare indirect rebound estimates using

the proportional spending patterns, income elasticities, and our constructed cross-price elasticity to inform the industrial ecology literature.

This chapter is organized as follows. Section 3.2 outlines our analytical model of direct and indirect rebound effects in a static general equilibrium framework, which integrates cross-price elasticities with supply chain emissions from an EEIO model. Section 3.3 describes our data sources for the direct rebound parameter, income elasticities, and household expenditures and shares from the 2004 U.S. Consumer Expenditure Survey (CES). Section 3.4 applies our model to simulate investments in different types of efficiency (e.g. saving electricity, natural gas, or gasoline expenditures) made by the average U.S. household and the corresponding direct and indirect rebound effects. Policymakers might be interested in achieving various goals with efficiency, thus we assess the rebound effect measured in terms of indicators such as primary energy consumption, GHG, NO_x, and SO₂ emissions. In addition, Section 3.4 describes the interaction between the direct and indirect rebound effect, a sensitivity analysis of key parameters, and variations in rebound effects by income. Section 3.5 concludes with a discussion of the reliability and relevance of our results for policy analysis.

3.2 Methods

We begin by defining a few conceptual terms related to the residential direct and indirect rebound effect. Suppose a household starts with a baseline demand for a fuel, E (e.g. electricity, gasoline), consumed by an appliance of efficiency ϵ (e.g. lumen-h/Wh, miles/gal), providing a single energy service S (e.g. lumen-hrs of lighting, miles driven), and holding constant all non-energy attributes (e.g. safety, comfort, quality, etc.), then Eq. 3-2 holds.

$$E = \frac{S(P_S, \epsilon)}{\epsilon} \quad 3-2$$

Where P_s , (e.g. \$/lumen-h, \$/mile), is the price of energy services. Eq. 3-2 reflects that households do not derive utility from energy per se, but from the useful energy services that a fuel or energy carrier provides when used with an appliance, i.e. the demand for energy is derived from the demand for energy services. Eq. 3-3 demonstrates the relationship between the price of energy, P_e , (e.g. \$/kWh or \$/gallon), the price of energy services, P_s , and appliance efficiency, ε .

$$P_e = P_s \varepsilon \quad 3-3$$

The direct rebound effect can be defined as an efficiency elasticity of energy services, $\eta_{S,\varepsilon}$ or the negative of the price elasticity of energy services, $-\eta_{S,P_s}$, (since $\eta_{S,P_s} < 0$) as seen in Eq. 3-4 and Eq. 3-5, respectively, which are defined in terms of the efficiency elasticity of energy demand, $\eta_{E,\varepsilon}$ (Berkhout et al., 2000; defs. 1 and 3 in Sorrell and Dimitropoulos, 2008).

$$\eta_{E,\varepsilon} \equiv \frac{\partial E}{\partial \varepsilon} \frac{\varepsilon}{E} = \frac{\varepsilon}{E} \left(\frac{1}{\varepsilon} \frac{\partial S(\varepsilon)}{\partial \varepsilon} - \frac{1}{\varepsilon^2} S \right) = \frac{\Delta S}{\Delta \varepsilon} \frac{\varepsilon}{S} - 1 \equiv \eta_{S,\varepsilon} - 1 \quad 3-4$$

$$\eta_{E,\varepsilon} = \frac{\partial E}{\partial \varepsilon} \frac{\varepsilon}{E} = \frac{\varepsilon}{E} \left(\frac{1}{\varepsilon} \frac{\partial S}{\partial P_s} \frac{\partial P_s}{\partial \varepsilon} - \frac{1}{\varepsilon^2} S \right) = \frac{\varepsilon}{E} \left(-\frac{\Delta S}{\Delta P_s} \frac{P_e}{\varepsilon^3} - \frac{1}{\varepsilon^2} S \right) = -\frac{\Delta S}{\Delta P_s} \frac{P_s}{S} - 1 \equiv \eta_{S,P_s} - 1 \quad 3-5$$

The representation of the direct rebound effect as an energy service price elasticity assumes that energy prices are exogenous, which may not generally be the case, as Hanly et al. (2002) demonstrate with U.K. travel statistics. For example, as gasoline and diesel fuel prices increase, consumers are more likely to invest in higher fuel economy vehicles. However, the upward-bias on energy service price elasticities that endogeneity introduces is still less than for energy price elasticities, given Hanly et al.'s (2002) bounding analyses on travel demand elasticities. The study of the endogeneity between energy prices and efficiency investments requires a

simultaneous equations econometric model with panel data, which is outside the scope of this chapter.

The indirect rebound effect is related to the re-spending of energy cost savings on $n-1$ other goods, O , with prices P_o , and the emissions associated with this induced consumption (Berkhout et al., 2000; Sorrell and Dimitropoulos, 2008; Schipper and Grubb, 2000). Consumer demand theory, in the form of elasticity aggregation properties and the Slutsky decomposition, helps to predict the pattern of household re-spending that occurs in response to the change in the price of energy services, as measured by cross-price elasticities of the demand for other goods with respect to the price of energy services, η_{O,P_S} , where

$$\eta_{O,P_S} \equiv \frac{\Delta O}{\Delta P_S} \frac{P_S}{O} \quad 3-6$$

To define the indirect rebound effect in terms of a cross-price elasticity and embodied or supply chain emissions for other goods, our analysis takes four steps. First, we examine the energy service and other expenditures of the household, Y . Second, we examine the energy or emissions from those expenditures, E , from a static general equilibrium perspective using input-output analysis, where market prices for energy and other goods are constant, but efficiency and energy service prices have changed. For simplicity, we assume the efficiency investment has the same capital cost as the less efficient technology it replaces, and has been financed from savings, so that we do not consider capital or financing costs in our re-spending scenarios. We will also consider the differences in rebound estimates using direct combustion and supply chain emissions data, assuming that all of the goods consumed by the household were produced in the U.S. Third, we derive a model for the direct and indirect rebound effect from their basic definitions. Fourth, we consider various approaches to approximate a parameter in the rebound model, the cross-price

elasticity, using proportional or average spending shares, income elasticity re-spending, or by constructing a cross-price elasticity which includes both substitution and income effects and which is consistent with consumer demand theory.

Step 1: Household Expenditures

There are three expenditure cases to consider: the base case, Y_B , the efficiency case (an engineering or input-output estimate) in which an efficiency investment has been made but assumes no change in energy service or other goods demand, Y_E , and a rebound case in which the demand for energy services is responsive to the price of energy services, Y_R . We represent these expenditures in terms of annual household disposable income, I , (excluding savings) and expenditure shares on energy services, w_s , and other goods, w_o .

Starting with the base case expenditures, decomposed in spending a single energy service (i.e. heating), Y_s and spending on other goods, Y_o .

$$Y_B = Y_s + \sum_{o=1;\neq s}^n Y_o = P_s S + \sum_{o=1;\neq s}^n P_o O = I(w_s + \sum_{o=1;\neq s}^n w_o) \quad 3-7$$

Suppose a household makes an efficiency investment which increases efficiency by $\delta = \Delta\epsilon/\epsilon$ and decreases the price of energy services by $\tau = \Delta P_s/P_s = \delta/(1+\delta)$. The percent increase in efficiency does not equal the percent decrease in the price of energy services; e.g. a 100% increase in vehicle fuel efficiency would decrease gasoline consumption by 50%. The engineering efficiency case then assumes no change in Y_o .

$$Y_E = Y_B - P_s S \frac{\Delta P_s}{P_s} = I \left(w_s (1 - \tau) + \sum_{o=1;\neq s}^n w_o \right) \quad 3-8$$

In the rebound case, energy service demand would increase by $\Delta S/S$ due to the direct rebound effect, or a decrease in the price of energy services, and other goods demand would change by

$\Delta O/O$ due to the cross-price elasticity, η_{O,P_S} . Writing $\Delta S/S$ and $\Delta O/O$ in terms of elasticities, using Eq. 3-5 and Eq. 3-6, we obtain:

$$\begin{aligned}
 Y_R &= Y_B - Y_S \frac{\Delta P_S}{P_S} + Y_S \frac{\Delta S}{S} + \sum_{o=1;\neq s}^n Y_o \frac{\Delta O}{O} \\
 Y_R &= Y_B - Y_S \frac{\Delta P_S}{P_S} - Y_S \eta_{S,P_S} \frac{\Delta P_S}{P_S} - \sum_{o=1;\neq s}^n Y_o \eta_{O,P_S} \frac{\Delta P_S}{P_S} \\
 Y_R &= I \left(w_S (1 - \tau - \eta_{S,P_S} \tau) - \sum_{o=1;\neq s}^n w_o (1 - \eta_{O,P_S} \tau) \right) \tag{3-9}
 \end{aligned}$$

Our expressions for household expenditure are a linear approximation of Nassen and Holmberg (2009)'s approach. For simplicity, we exclude consideration of the emissions impacts of household savings, as these are likely to depend on the type of savings instrument, and could also represent delayed consumption, which should be studied in a dynamic framework. In addition, the income elasticity parameters we use from Taylor and Houthakker (2010) use total expenditure data rather than income data to estimate income elasticities.

Step 2: Energy and Emissions from Expenditures

We next consider the energy or emissions implications of the three expenditure patterns above, using environmentally-extended input-output analysis (EEIO), which represents a static general equilibrium framework for evaluating the environmental implications of production and consumption activities. We use the publicly available purchaser price, economic input-output lifecycle assessment (EIO-LCA) model for the 2002 U.S. economy, the latest year for which the data are available (Henderickson et al., 2006; www.eiolca.net). EIO-LCA contains a 428-sector industry by commodity structure, to which household expenditure data and elasticities can be

matched. In the EEIO framework, the supply chain energy or environmental emissions associated with the household's expenditures can be represented as in Eq. 3-10.

$$E = ZY = V(I - A)^{-1} IY \quad 3-10$$

Where Y is a [428x1] vector of household expenditures, I is the identity matrix, and A is a [428x428] unitless matrix representation of production functions for all sectors of the economy. V is the [1x428] vector of direct energy (J) or emissions (e.g. kg CO₂e) per dollar of expenditure for final goods, also known as the direct energy or emissions intensity. The matrix $(I-A)^{-1}$ represents the Leontief inverse (Leontief, 1970), which transforms direct emissions intensities, V , into supply chain emissions intensities, Z [1x428], assuming constant, national average prices, constant returns to scale, and linear production functions, which assumes zero fixed costs (Lenzen and Day, 2002). For natural gas and gasoline fuels, we add combustion emissions from the use of these fuels to the supply chain emissions vector, Z , by converting 2004 household expenditure data (BLS, 2004) into physical quantities (e.g. cubic feet, gallons) by dividing by 2004 fuel prices from the EIA and multiplying by emissions factors for each unit of fuel (EIA, 2011).

Step 3: Direct and Indirect Rebound Model

By using Eq. 3-10 with the three expenditure cases in Eqs. 3-7 to 3-9, following the basic definition of the rebound effect in Eq. 3-1, and replacing Y_0 by the product of income and budget shares, w_0I , we can derive a model of the direct and indirect rebound effects, similar to Nassen and Holmberg (2009) and Freire-Gonzalez (2011), who draws from Druckman et al. (2010) to model re-spending with savings. Our model differs from Nassen and Holmberg (2009) in that we take a linear approximation of household spending under increased energy service prices. We differ from Freire-Gonzalez (2011) in that we use energy service price elasticities as a measure of

the direct rebound effect, we explore substitution effects of the cross-price elasticity, and we provide an analytical expression of direct and indirect rebound effects in terms of elasticities and embodied emissions:

$$R[\%] = 1 - \frac{AES}{PES} = 1 - \frac{E_B - E_R}{E_B - E_E} = \frac{E_R - E_E}{E_B - E_E}$$

$$E_B = z_S y_S + \sum_{O=1;\neq S}^n z_O y_O$$

$$E_E = z_S y_S (1 - \tau) + \sum_{O=1;\neq S}^n z_O y_O$$

$$E_R = z_S y_S (1 - \tau - \eta_{S,P_S} \tau) + \sum_{O=1;\neq S}^n z_O y_O (1 - \eta_{O,P_S} \tau)$$

$$R[\%] = \frac{-z_S y_S \eta_{S,P_S} \tau - \sum_{O=1;\neq S}^n z_O y_O \eta_{O,P_S} \tau}{z_S y_S \tau}$$

$$R[\%] = -\eta_{S,P_S} - \frac{\sum_{O=1;\neq S}^n z_O w_O \eta_{O,P_S}}{z_S w_S} \quad 3-11$$

where the direct rebound, R_D is

$$R_D = -\eta_{S,P_S}$$

and the indirect rebound R_I is

$$R_I = -\frac{\sum_{O=1;\neq S}^n z_O w_O \eta_{O,P_S}}{z_S w_S}$$

Note in that our measure of the direct and indirect rebound in Eq. 3-11, potential energy/emissions savings (PES) is equal to $E_B - E_E = z_s y_s \tau = z_s w_s I \tau$, which is a general equilibrium estimate of the supply-chain impacts of reducing household consumption of a particular fuel, and similar to the approach taken by Guerra and Sancho (2010) in their study of the economy-wide rebound effect in Spain. Guerra and Sancho (2010) argue that partial equilibrium (engineering) measures of PES, as traditionally used by ‘rebound economists’, lead to upward- or downward-biased measures of the economy-wide rebound effect, depending on elasticities of substitution for energy. Alternatively, if utilities and policymakers do not use input-output models in their energy efficiency program evaluations, one could argue that partial equilibrium engineering estimates should be used for PES. In this case, there would be a downward pressure on the indirect rebound as reduced household energy expenditures also lead to greater supply-chain reductions in energy consumption, similar to the ‘disinvestment effect’ of the economy-wide rebound effect (Turner, 2009), in addition to upward pressures from embodied energy/emissions when the household re-spends energy expenditure savings from efficiency on other goods. We leave consideration of the impacts of partial equilibrium measures of PES on estimates of the indirect rebound for future work.

Step 4: Approximating Cross-Price Elasticities

We study the bounds on η_{O,P_S} to estimate the indirect rebound effect, given an estimate of the direct rebound effect, η_{S,P_S} , consistent with the literature described in Section 3.3.1 . We assume that all electric-end uses have a price elasticity similar to that of space-cooling, that all natural gas end-uses have a price elasticity similar to that of space heating, and all gasoline end-uses have a price elasticity similar to that of driving; in other words, that each fuel provides a single energy service. This implies that the share of expenditures spent in the fuel is equal to the share of

expenditures spent in the energy service, $w_e = w_s$. This assumption is fairly accurate for gasoline and natural gas, but restrictive for electricity. For example, if space cooling represents only a portion of electricity expenditures, this would decrease the space cooling budget share and increase the emissions from non-space cooling spending, which now includes other electric end-uses. We investigate the sensitivity of the indirect rebound effect to budget share, emissions intensities, and other factors in Section 3.4.3. Using the single service per fuel assumption, the basic properties of elasticities (such as Engel Aggregation, Cournot Aggregation, and the Slutsky decomposition) can be applied to the demand for energy services and non-energy services. Engel aggregation, obtained by differentiating the budget constraint by income, also implies that the income elasticity of the demand for an energy service is equal to the income elasticity of the demand for energy, $\eta_{S,I} = \eta_{E,I}$. In addition, using the single service per fuel assumption still allows P_E and P_S to differ from each other according to Eq. 3-3, which is the basis for the direct and indirect rebound effect.

Our approximations for the cross-price elasticity of the demand for other goods with respect to the price of energy services are based on the Slutsky decomposition, which is described in Section 3.7.3 of the SI, and shown in Eq. 3-12.

$$\eta_{O,P_S} = \eta_{O,P_S} \Big|_U - w_S \eta_{O,I} \quad 3-12$$

There are many possible approximations for η_{O,P_S} which could be used in principle.

Alternatively, one could econometrically estimate cross-price elasticities with cross-sectional, time-series, or panel expenditure data, appliance/vehicle efficiency collected at the household level, geographically delineated commodity prices, and other variables needed to account for self-selection of efficient technologies. Gillingham (2011) provides a self-selection model for the case

of choosing vehicle efficiency. Due to data limitations, we focus on constructing cross-price elasticities given an estimate of the direct rebound effect to provide a bounding analysis on the substitution effect of the indirect rebound. We examine three possible approximations for η_{O,P_S} , the first two of which, proportional spending and income elasticity spending, were explored by numerically by Freire-Gonzalez (2011) but not presented in an analytical expression for the direct and indirect rebound effect. Our contribution, the third approximation for η_{O,P_S} , explores the extent of the substitution effect of the indirect rebound effect, which has not yet been studied.

The three approximations for η_{O,P_S} include:

- (1) the proportional spending (PS) case, which assumes $\eta_{O,I} = 1$, $\eta_{O,P_S}|_U = 0$ for all non-energy service goods, O , and $\eta_{O,P_S} = -w_S$. Since $-\eta_{S,P_S}$ percent of energy cost savings were re-spent on energy services, only the remaining $(1 + \eta_{S,P_S})$ percent of energy cost savings can be re-spent on other goods, if the budget constraint is to be met. In addition, if all re-spending in the energy service, S , is absorbed in the direct rebound effect, a factor of $1/(1 - w_S)$ must be included to ensure that all extra energy cost-savings are re-spent. Without adding the $(1 + \eta_{S,P_S})/(1 - w_S)$ factor, the proportional spending approximation of the cross-price elasticity would either break the budget constrain or restrict η_{S,P_S} to be $-w_S$.

$$R_{I-PS} = \frac{\sum_{O=1;\neq S}^n z_O w_O w_S (1 + \eta_{S,P_S})}{z_S w_S (1 - w_S)}$$

$$R_{I-PS} = \frac{\sum_{O=1;\neq S}^n z_O w_O (1 + \eta_{S,P_S})}{z_S (1 - w_S)}$$

- (2) the income elasticity (IE) case, which assumes $\eta_{O,P_S}|_U = 0$ for all non-energy goods, and $\eta_{O,P_S} = -w_S \eta_{O,I}$. This approximation implies that there are no substitution effects and only income effects with a change in energy service prices. As in the proportional spending case, since $-\eta_{S,P_S}$ percent of energy cost savings were re-spent on energy services, only the remaining $(1 + \eta_{S,P_S})$ percent can be re-spent on other goods, and if all re-spending in the energy service, S, is absorbed in the direct rebound effect, a factor of $1/(1 - w_S \eta_{S,P_S})$ must be included so that the budget constraint is met. Without the $(1 + \eta_{S,P_S})/(1 - w_S \eta_{S,P_S})$ factor, this approximation of household re-spending would have to restrict η_{S,P_S} to be $-w_S \eta_{S,I}$, in order to meet the budget constraint.

$$R_{I-IE} = \frac{\sum_{O=1;\neq S}^n z_O w_O \eta_{O,I} (1 + \eta_{S,P_S})}{z_S (1 - w_S \eta_{S,P_S})} \quad 3-14$$

- (3) the constant cross-price elasticity (CP) for non-energy services case, which assumes $\eta_{O,P_S}|_U = C = \frac{-w_S(\eta_{S,P_S} + w_S \eta_{S,I})}{\sum_{O=1;\neq S}^n w_O}$, and $\eta_{O,P_S} = \frac{-w_S(\eta_{S,P_S} + w_S \eta_{S,I})}{\sum_{O=1;\neq S}^n w_O} - w_S \eta_{O,I}$ and is derived in Section 3.7.3 of the SI. This assumption places restrictions on the curvature of the household's utility function, and may underestimate the degree of substitution between energy services and other goods, but is useful to examine how substitution effects compare to income effects. The cross-price elasticity derivation relies on the Cournot aggregation property of elasticities, which is obtained by differentiating the budget constraint by the price of energy services, and so maintains the budget constraint without the need for additional calibration factors (see Section 3.7.3 of the SI).

$$R_{I-CP} = \frac{\sum_{O=1;\neq S}^n z_O w_O (\eta_{S,P_S} + w_S \eta_{S,I})}{z_S \sum_{O=1;\neq S}^n w_O} + \frac{\sum_{O=1;\neq S}^n z_O w_O \eta_{O,I}}{z_S} \quad 3-15$$

Note that in all three cases, Eqs. 3-13 to 3-15, since $\eta_{S,P_S} < 0$, the higher the direct rebound effect, the lower the indirect rebound effect, because fewer energy cost savings will be available for re-spending. Also note that these direct and indirect rebound effects in percent do not depend on the percent reduction in energy expenditures, τ . However, the consequence of the rebound effect in emissions (e.g. J, kg CO₂e), or the difference between potential and actual energy or emissions savings (PES-AES) after accounting for direct and indirect rebound effects, obtained by multiplying the rebound in percent by PES, or $z_S y_S \tau = z_S w_S I \tau$, does depend on τ . In Section 3.4, we will show results in terms of percent direct and indirect rebound in primary energy, CO₂e, NO_x, and SO₂ (Eq. 3-13 to Eq. 3-15), as well as the consequences of the rebound effect in energy/emissions, obtained by multiplying the percent rebound against a common PES baseline across energy efficiency interventions in electricity, natural gas, or gasoline services.

While the utility-maximizing model (see Section 3.7.2 of the SI) underlying the Slutsky decomposition and other price elasticity properties describes the behavior of an individual household, the own-price and cross-price elasticity estimates are typically measured by exploiting price, income, and demand variations in time-series or cross-sectional survey data and represent the behavior of the average household in the survey sample. This disconnect between the individual utility model and average household elasticity estimates reveals an important caveat for interpretation: rebound models should not be used to predict a particular household's response to changes in energy service prices, since individual elasticities are not measured. Instead, rebound models provide a guide to policymakers and utilities on the average household's take-back of

efficiency savings due to price responses for the population, geographic area, and time frame in which the price elasticities are measured. In this context, the percentage reduction of energy expenditures, τ , could be large ($>25\%$) for an individual household but τ could be small ($<10\%$) for a given population, since not all households will be willing or able to make efficiency improvements due to capital constraints and other barriers to efficiency. With large reductions in energy service expenditures, τ , for a population, it is conceivable that energy prices would change, leading to economy-wide rebound effects, which are not captured by Eqs. 3-11 to 3-15. In the long-term, such changes in energy prices could lead to shifts in economic structure and disinvestment effects (Greening et al., 2000, Turner, 2009). Due to barriers to energy efficiency investments and the possibility of economy-wide rebound effects, Eqs. 3-11 to 3-15 are only valid to study direct and indirect rebound effects for a moderate τ averaged over a population.

3.3 Data

3.3.1 Energy Service Own-Price Elasticities for Direct Rebound Effects

We assume the range in direct rebound effects is between 0-15% for electricity and natural gas services (i.e. space cooling and heating), and between 5-20% for gasoline services (i.e. driving), which are consistent with the range of studies of the efficiency elasticity and energy service price elasticity for home heating and cooling and personal transport (see Table 3-2 of the SI). In our mean results, we use a direct rebound parameter of 10%, and use the ranges in the direct (and calculated indirect) rebound effects to provide error bars. We use the same mean direct rebound estimate for each fuel so that the differences in indirect rebound effects by fuel are clearly apparent.

We also study the variation in the rebound effects for average U.S. households of varying incomes. There are two sources of variation in the rebound effect by income: variations in the

direct rebound effect and variations in the re-spending patterns by household income. To examine income variations in the direct rebound effect, we use income quantile regression estimates of electricity price elasticities by Reiss and White (2005). As these are energy price elasticities, they overestimate the direct rebound effect, and underestimate the indirect rebound effect, but are indicative of the trends across income brackets. In addition, these price-elasticities were measured for households in California, and using California utility pricing structures, which limits the validity of these estimates for households outside of the state. Differentiated price response by income is contested, as other researchers (Alberini, 2011) find no such differences by income (and higher price elasticities) using a city-level panel of electricity expenditures. We also use the Gillingham's (2011) estimates of gasoline price elasticity of driving by income quantile to study rebound effects in gasoline efficiency. These estimates also rely on vehicle registration and emissions data for the state of California, which limits its validity to other U.S. states. To our knowledge, own-price elasticities by income quantile are not available for natural gas or its services.

3.3.2 U.S. Consumer Expenditure Survey

We model average U.S. household consumption using the U.S. Consumer Expenditure Survey (CES) for 2004 to represent average household demand for goods and services, including energy. We use 2004 data, the closest year to 2002 for which the Bureau of Labor Statistics (BLS) applied improved procedures for income imputation in the CES (BLS, 2012), and convert these expenditures into 2002\$ using the U.S. all-urban, all-goods consumer price index (BLS, 2002) as input to the EIO-LCA model. More details about the survey are described in Section 3.7.5. We aggregate these data, reported in 674 categories in pre-publication tables, into $n=13$ categories for clarity of interpretation of the indirect rebound results. See Section 3.7.4 of the SI for lifecycle

energy and GHG, NO_x, and SO₂ emissions intensities per dollar for 13 categories of household expenditures.

3.3.3 Expenditure Elasticities

We use expenditure/income elasticities from Taylor and Houthakker (2009) which uses four quarters of CES data for 1996, for six exhaustive categories of expenditures: food, shelter, utilities, transportation, health, and miscellaneous goods. U.S. income (expenditure) elasticities are only available for these 6 categories because of the lack of price indices for a broad number of sectors in the economy, which are required to estimate a set of income and price elasticities within complete demand systems models that is consistent with consumer demand theory (Taylor and Houthakker, 2010). Taylor and Houthakker (2009) estimate expenditure elasticities using five different demand system models: the Linear Expenditure System (LES), Almost Ideal Demand System (AIDS), Direct Addilog (DA), Indirect Addilog (IA) and Double-Log (DL) system. We compute indirect rebound effects using these five sets of elasticities to assess the uncertainty in the indirect rebound effect under differing assumptions about the household's utility function. The Linear Expenditure System (LES) and Indirect Addilog (IA) results, shown in Table 3-1, correspond to the cases with the highest and lowest estimates of the indirect rebound effect. The expenditure shares in 2004 differ slightly from the average budget shares during the period studied by Taylor and Houthakker, so that Engel aggregation does not hold. We normalize the expenditure elasticities so that the Engel aggregation property does hold, to ensure that the budget constraint is met. These 6 Taylor-Houthakker categories are mapped to our 13 categories to assign income elasticities.

Table 3-1: Houthakker-Taylor Expenditure Elasticities used in Rebound Simulations

Category	2004 Budget Share	LES- Normalized Expenditure Elasticity	IA- Normalized Expenditure Elasticity	Marginal Spending Share (LES)	Marginal Spending Share (IA)
Food	0.08	0.12	0.36	1%	3%
Shelter	0.15	0.54	0.87	8%	13%
Appliances	0.03	0.54	0.87	1%	2%
Electricity	0.02	0.14	0.40	0.3%	1%
Natural Gas	0.01	0.14	0.40	0.2%	1%
Other Utilities	0.04	0.14	0.40	1%	2%
Gasoline	0.04	2.3	1.3	9%	5%
Transportation Equip.	0.11	2.3	1.3	26%	14%
Public Transit	0.002	2.3	1.3	0.4%	0.2%
Air Travel	0.01	2.3	1.3	2%	1%
Health Care	0.04	0.27	0.52	1%	2%
Financial Services	0.20	0.27	1.3	22%	24%
Misc.	0.26	1.1	1.2	29%	32%

Notes: LES = Linear Expenditure System, IA = Indirect Addilog System. Spending shares may not sum to 100% because of rounding truncation. Sources: Taylor and Houthakker, 2010; 2004 Consumer Expenditure Survey.

3.3.4 U.S. Household Expenditures, Spending Patterns, and Environmental Footprints

Figure 3-1 shows the expenditures and environmental supply chain emissions (also known as footprints) for the average U.S. household in 2004 (in 2002\$), aggregated to the six Houthakker-Taylor categories. The expenditures and CO₂e footprint and is similar to the aggregate U.S. residential figures in 2004 calculated by Weber and Matthews (2008) using the same CES data with a trade-linked, multi-regional version of the 1997 EIO-LCA model.

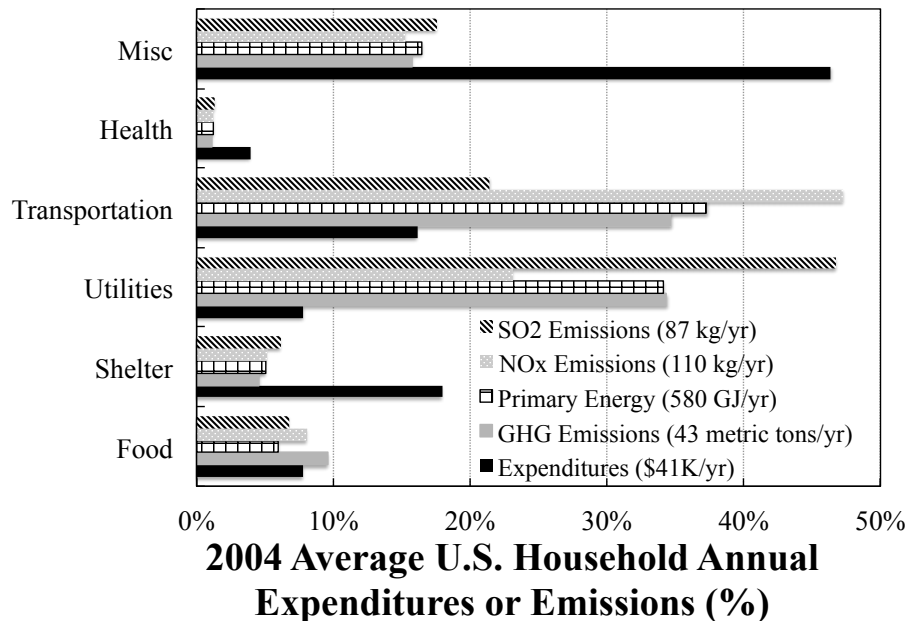
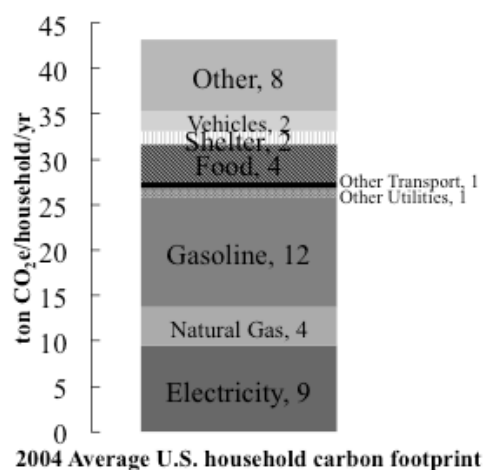

Figure 3-1: Annual expenditures and emissions for the average U.S. household in 2004. Notes: Expenditure data are from 2004 Consumer Expenditure Survey (BLS, 2004) converted to 2002\$ by CPI method (BLS, 2002). Embodied emissions are estimated using the 2002 EIO-LCA model (www.eiolca.net).

While transportation and utilities form a small portion of household expenditures, as expected, they are the largest sources of primary energy consumption and GHG, NO_x, and SO₂ emissions, as seen in Figure 3-2a. The differences between the proportional spending, income elasticity, and cross-price elasticity re-spending scenarios using the LES and IA sets of income elasticities are shown in Figure 3-2b. The differences gasoline demand across re-spending scenarios will drive indirect rebound results, given the large portion of the household's carbon footprint attributed to gasoline. The differences in re-spending patterns between the income elasticity and cross-price elasticity scenarios are minimal given a 10% direct rebound, but as we will show in the next section, appear to be greater if households exhibit a larger direct rebound from efficiency investments.

A: Gasoline and electricity contribute the largest portions of the average U.S. household's carbon footprint



B: Comparison re-spending patterns with efficiency resulting in 10% electricity expenditure savings and 10% direct rebound effect

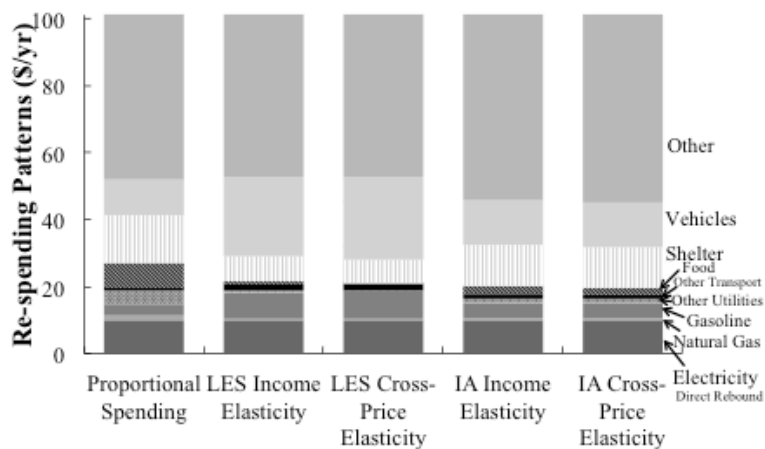

Figure 3-2a-b: (A) 2004 average U.S. household carbon footprint. (B) Comparison of re-spending patterns for electricity service efficiency.

Sources/Notes: The 2004 U.S. consumer expenditure survey (CES) data are from BLS(2004) (in \$2002) (BLS, 2002). Embodied emissions are from the 2002 EIO-LCA model (www.eiolca.net). The sets of income elasticities (LES=linear expenditure system; IA=indirect addilog) are from Taylor and Houthakker (2010) using historical U.S. CES data, where LES income elasticities correspond to an upper estimate of the indirect rebound and IA income elasticities correspond to a lower estimate of the indirect rebound.

3.4 Results

In this section, we demonstrate an application of our model to simulate direct and indirect rebound effects from efficiency investments made by the average U.S. household to achieve various objectives, such as reducing supply-chain and combustion primary energy, GHG, NO_x, or SO₂ emissions, assuming domestically produced goods and services with 2002 U.S. economic structure, prices, and environmental impacts. We also show how these rebound effects, in physical units or percentages, vary depending on the fuel or energy carrier saved (whether electricity, natural gas, or gasoline), and other parameters in a sensitivity analysis. Not surprisingly, we find that the direct and indirect rebound effects vary with the policy goal and fuel saved as shown in Figure 3-3. Since we treat the direct rebound effect as a parameter (10%) across all four energy and emissions cases, we will focus the discussion of results on the indirect

rebound effect. Under our assumptions of a 10% direct rebound from an energy efficiency intervention which reduces household expenditures in either electricity, natural gas, or gasoline, and the U.S. economic structure, energy prices, and electric grid mix of 2002, the indirect rebound is a similar magnitude ($\leq 10\%$) as seen in Figure 3-4, and there is no chance of backfire, or rebound greater than 100% and increased energy consumption compared to before the efficiency investment. If the direct rebound effect were much larger (close to 100%), backfire would be possible and indirect rebound effects would be small, as seen in Figure 3-5. If we had considered a sustainable consumption measure like eating locally-produced food, which also yielded expenditure savings for the household, the embodied emissions of re-spending and indirect rebound effects would be larger because food is not as energy- and emissions-intensive as fuels and electricity. In addition, as energy prices and the U.S. electric grid mix changes, the indirect rebound will also change, as seen in Figure 3-6. Our indirect rebound estimates are lower than in prior indirect rebound studies (Alfredsson, 2004; Nassen and Holmberg, 2009; Girod and de Haan, 2010; Druckman et al., 2011; Murray, 2011; Freire-Gonzalez, 2011; Chitnis et al., 2012) because of our focus on the U.S., which has lower energy prices and a more carbon-intensive electric grid, so that energy efficiency interventions reduce more energy and emissions per dollar of energy expenditure reduced and lead to lower indirect rebound than in prior European studies.

3.4.1 Indirect Rebound Effects Vary by Policy Goal and Type of Fuel Efficiency

Figure 3-3 shows the net embodied (supply chain) CO₂e emissions, after accounting for energy efficiency savings, as well as direct and indirect rebound effects, for four abatement goals or objectives. The abatement objectives were chosen so that electricity efficiency provides the same level of embodied CO₂e reductions across scenarios, and to provide a comparison with other types of fuel efficiency investments. The abatement objectives, measured from an engineering

assessment and before accounting for the re-spending behavior of households, include energy efficiency measures that lead to

- (1) 1 ton embodied CO₂e emissions reductions in a particular fuel
- (2) \$107 (in 2002\$) of annual energy bill savings in a particular fuel
- (3) a 12 GJ reduction in primary energy use with a particular fuel
- (4) a $\tau=10.5\%$ (rounded to 10%) reduction in energy bills in a particular fuel, assuming constant 2004 energy prices (in 2002\$) and a $\delta=11.7\%$ improvement in appliance energy efficiency (where $\tau=\delta/(1+\delta)$; see Section 3.2).

The percentage of appliance efficiency improvement, δ , and corresponding percentage of energy cost savings, τ , varies by fuel for each of these scenarios, except for the electricity efficiency cases, and for the fourth scenario.

Figure 3-3 shows that that the variations in net supply chain CO₂e emission after accounting for direct and indirect rebound effects by type of fuel efficiency are greatest for the third and fourth scenarios, for abatement objectives framed in terms of reductions in primary energy consumption, or as a percentage reduction in energy bills for a fuel.

The differences in net CO₂e emissions across energy efficiency interventions in Figure 3-3 largely stem from the relative differences in CO₂e intensity per joule (J) of primary energy of the fuel, household budget share for the fuel, and 2004 commodity prices (in 2002\$), with direct and indirect rebound effects appearing as smaller effects. For example, since the average U.S. household's annual expenditures on gasoline are much higher than for electricity and natural gas, a policy goal framed in terms of percent reductions in residential energy consumption or expenditures will result in the greatest CO₂e emissions reductions with efficiency in gasoline-fueled vehicles, even after accounting for respending behavior, i.e. direct and indirect rebound effects. Natural gas efficiency appears to result in the fewest net CO₂e reductions, because it forms a smaller portion of the household's budget (see Section 3.7.4 of the SI) and is less CO₂e-intensive fuel per joule of primary energy than either electricity or gasoline.

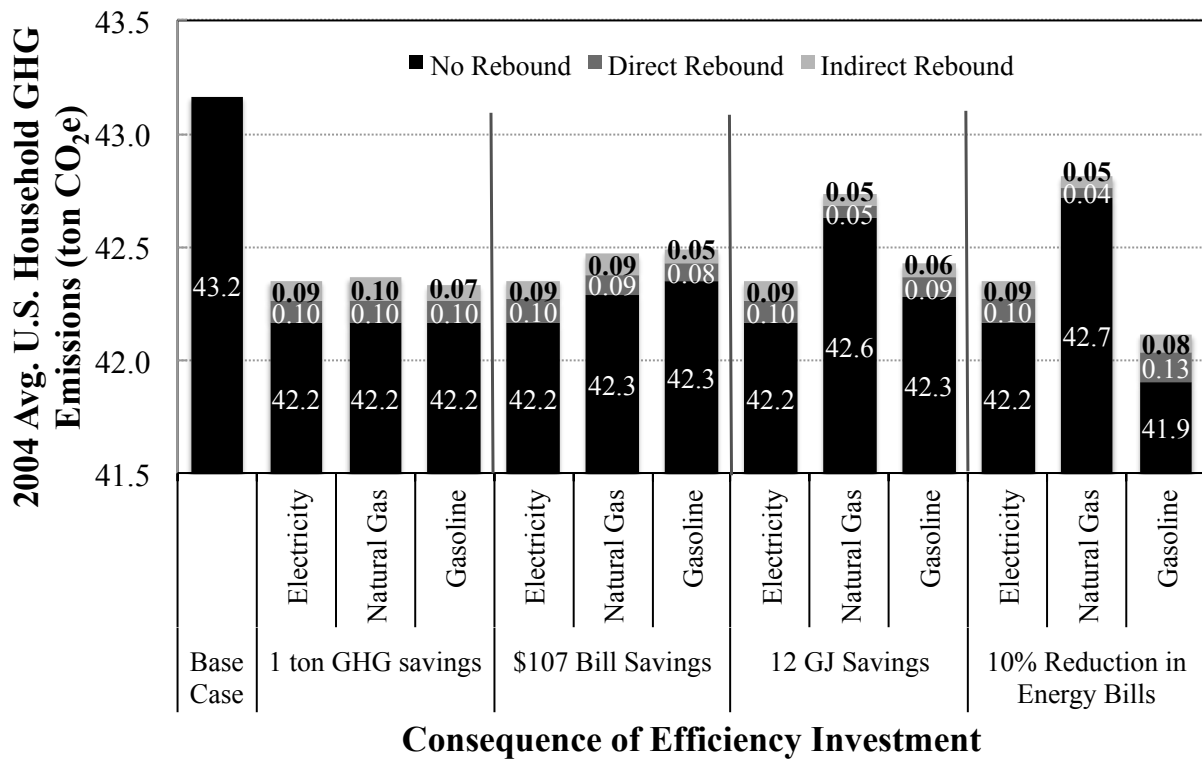
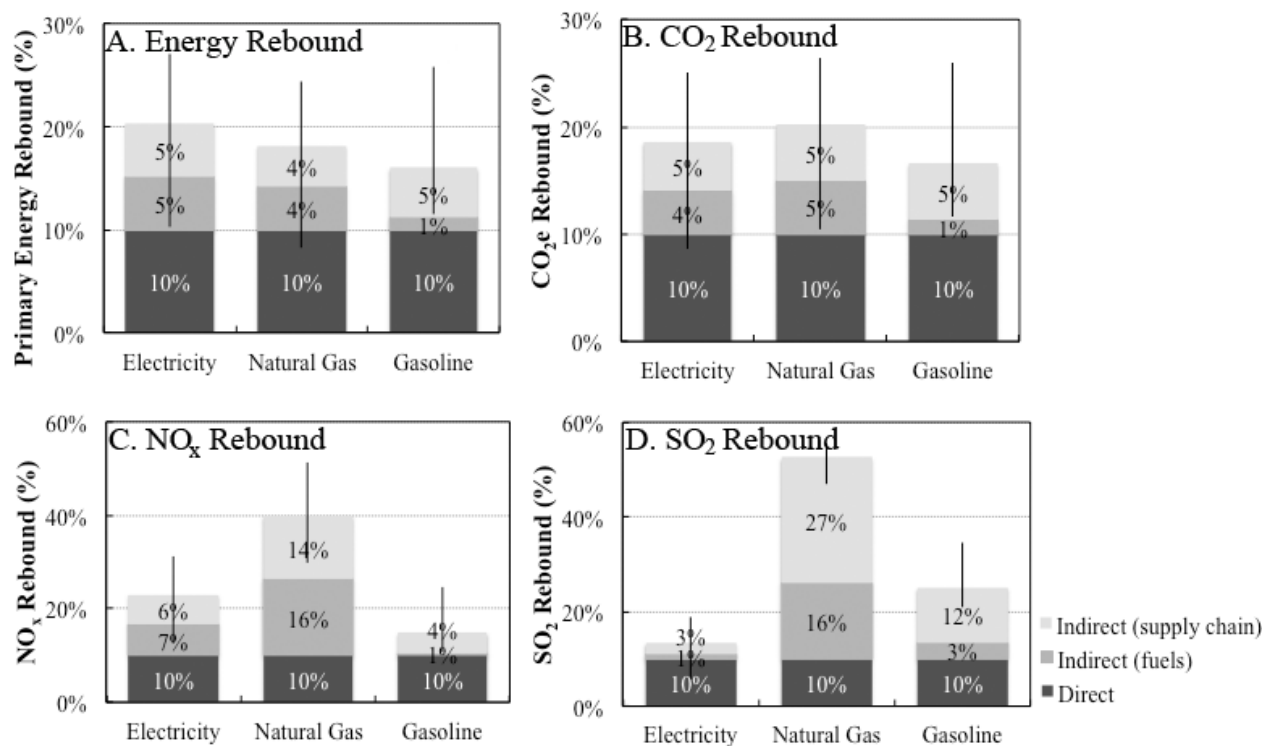

Figure 3-3: 2004 average U.S. household embodied GHG emissions with energy efficiency investments in electricity, natural gas, and gasoline services, after accounting for direct and indirect rebound effects.

Notes: The base case represents emissions before an efficiency investment, and the four scenarios represent engineering assessments, before accounting for re-spending behavior, of abatement objectives or policy goals to be achieved with efficiency.

Sources: Authors' calculations with 2002 purchaser price EIO-LCA model (www.eiolca.net), 2004 Consumer Expenditure Survey (BLS, 2004) in 2002\$, and income elasticities from Taylor and Houthakker (2010).

Figure 3-4a-d shows the direct and indirect rebound effects in percent, for all three fuels considered in terms of primary energy, CO₂e, NO_x, and SO₂ emissions. The error bars represent a 15% range in direct rebound effects and a smaller 1-3% range in indirect rebound effects computed using different systems of income elasticity estimates from Taylor and Houthakker (2010). As implied by Eq. 3-11, the percentage rebound does not depend on the percent reduction in energy bills, τ , resulting from an efficiency investment saving a particular fuel under constant energy prices.



Fuel Saved with Efficiency

Figure 3-4a-d: Direct and indirect rebound effects vary by fuel type and environmental impact of consumption, whether primary energy or CO₂, NO_x, or SO₂ emissions.

Notes: Rebound effects are a percentage of potential energy savings estimated with an engineering or econometric assessment with a static, general equilibrium, fixed price system.

Sources: Authors' calculations with www.eiolca.net; 2004 Consumer Expenditure Survey (BLS, 2004), and Taylor and Houthakker (2010).

Indirect rebound effects are divided into combustion (scope 1) emissions from re-spending energy cost savings on other fuels, i.e. re-spending savings from an electricity efficiency investment on natural gas heating or gasoline for driving, and supply chain (scope 3) emissions embodied in purchases of all other goods. To estimate combustion emissions, we assume 2004 commodity prices in 2002\$ of 7.9 cents/kWh for electricity, \$1.42/gallon for gasoline, and \$8.71 per thousand cubic feet for natural gas. To estimate NO_x emissions from gasoline, which are a function of miles driven, we assume that the household drives vehiclesⁱⁱⁱ with a fuel economy of 19.6 miles/gallon in the base case (BTS, 2012), for a total of 21,800 miles per year. Indirect

ⁱⁱⁱ There are just under 2 vehicles on average per household, so that each vehicle is used to drive almost 11,000 miles per year.

rebound estimates using scope 1-3 emissions are more than 50% higher than estimates using scope 1 emissions for natural gas or gasoline or scope 2 emissions for electricity alone.

Figure 3-4a-b shows that rebound effects are modest in primary energy consumption and GHG emissions for all three fuels considered. The indirect rebound effects from electricity and natural gas efficiency are due to re-spending of energy cost savings on transportation and miscellaneous services, which constitute the largest portions of the next dollar spent (see Table 3-1). Gasoline efficiency results in the smallest indirect rebound effect because re-spending in gasoline is counted as the direct rebound effect, and as household substitutes into gasoline and its complements it also substitutes out of electricity and natural gas, resulting in a lower level of emissions for these expenditure categories than in the no-rebound case. The only potentially large (>20%) indirect rebound effects are in NO_x and SO_2 emissions, shown in Figure 3-4c-d, for the case of natural gas efficiency, due to re-spending natural gas cost savings on substitute goods such as electricity, the largest source of SO_2 emissions, or gasoline, the largest source of NO_x emissions per dollar of expenditure.

3.4.2 Respending Scenarios for Direct and Indirect Rebound Effects

We find that the higher the direct rebound effect, the lower the indirect rebound effect. This result is expected from Eqs. 3-13 to 3-15, since the greater the increase in household energy service demand, the lower the energy cost savings available for respending on other goods, assuming the same level of expenditures before and after the efficiency investment. Figure 3-5 illustrates the relationship between indirect CO_2e rebound effects from electricity efficiency, and the direct rebound parameter, which varies between 0-1.0. Figure 3-5 also compares indirect rebound estimates for electricity, gasoline, and natural gas efficiency under assumptions of proportional re-spending (PS), income elasticity re-spending (IE), and our cross-price elasticity

model (CP), using Linear Expenditure System (LES) and Indirect Addilog (IA) systems of income elasticities for U.S. households, which serve as upper bound and lower bounds of the indirect rebound effect in our model. Only the cross-price elasticity model is flexible enough to allow for the possibility of backfire, or rebound greater than 100% (Saunders, 2000) with a direct rebound near 100%. The only cases in which backfire could occur is with efficiency in electricity services or natural gas services, and using the Linear Expenditure System (LES) income elasticities measured by Taylor and Houthakker (2010) in our constructed cross-price elasticity re-spending scenario, since the LES predicts highly elastic gasoline demand as incomes rise.

For electricity efficiency, the proportional spending (PS) assumption results in a lower estimate of the indirect rebound effect, but is still within the range of indirect rebound effects predicted by the Taylor-Houthakker income elasticities. For natural gas efficiency, the PS assumption is near the mean estimate of indirect rebound effects from the two income elasticities. However, for gasoline efficiency, PS overestimates the indirect rebound effect, since income elasticities predict that households facing a reduction in the price of driving will tend to re-spend on low CO₂e-intensity goods such as financial services and other miscellaneous goods.

Within a plausible 5-25% range for the direct rebound effect, highlighted in Figure 3-5, the income elasticity (IE) method is very similar to our cross-price elasticity (CP) method, implying that under our assumption of constant cross-price elasticities for non-energy services, substitution effects are small. Future work could empirically test this assumption or develop alternate methods for constructing cross-price elasticities. In cases where the direct rebound effect is higher than the 5-25% range, such as for low-income households or in developing countries, substitution effects may be more important.

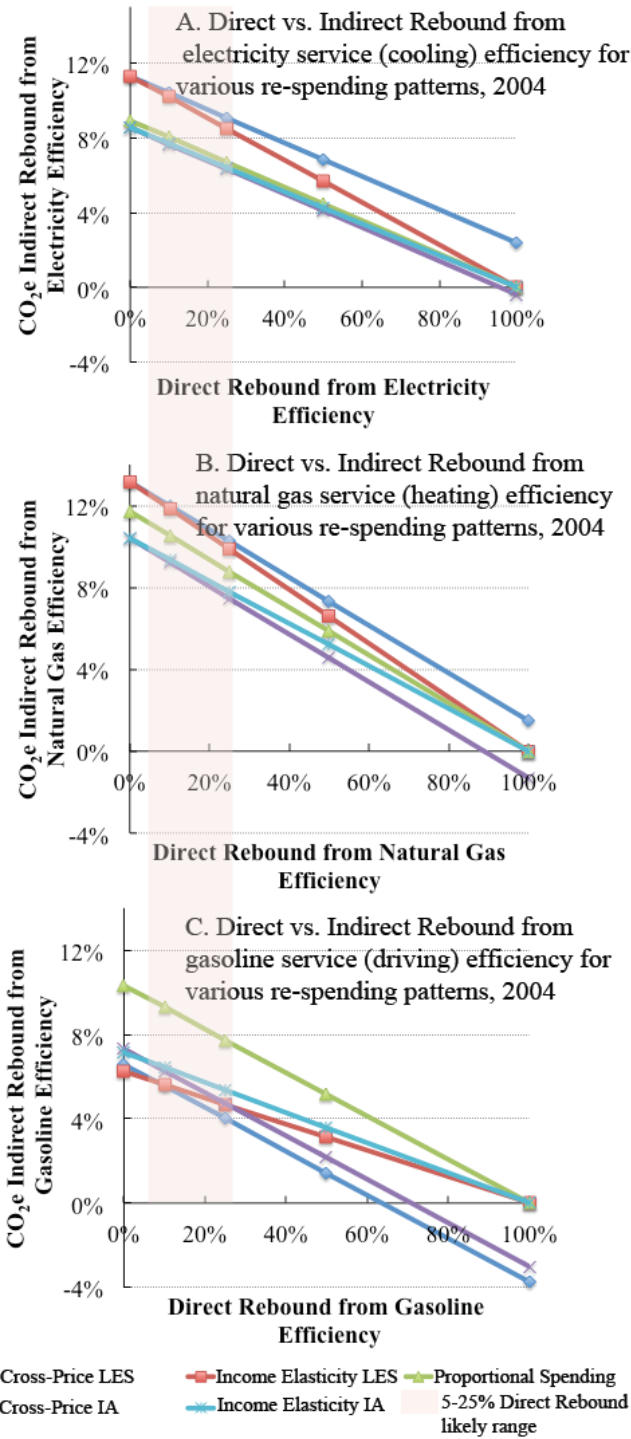

Figure 3-5a-c: Direct and indirect rebound effects for (A) electricity efficiency, (B) natural gas efficiency, and (C) gasoline efficiency under re-spending scenarios using proportional spending, income elasticities, and cross-price elasticities.

Sources: Income elasticities using the linear expenditure system (LES) and indirect addilog (IA) demand system models are from Taylor and Houthakker (2010), and budget shares from 2004 Consumer Expenditure Survey (BLS, 2004).

The rebound results in this study are for the average U.S. household. Of course, an individual household may experience a higher or lower indirect rebound effect depending on their spending patterns. Re-spending electricity cost savings from an efficiency investment entirely on natural gas for home heating or gasoline for personal travel, would lead to indirect rebound effects in GHG emissions as high as $Z_{ng}/Z_{elec} = 94\%$ and $Z_{gas}/Z_{elec} = 87\%$, respectively, where Z_{ng} , Z_{gas} , and Z_{elec} represent the embodied emissions per dollar of expenditure, E_s , for each efficiency type (see Section 3.7.4 of the SI).

3.4.3 Sensitivity Analyses for the Indirect Rebound Effect

The results in Figure 3-3 and Figure 3-4a-d were obtained with the 2002 EIO-LCA model estimates of embodied energy and emissions for the U.S. economy, assuming 2004 prices in 2002\$, household spending patterns in 2004, and the 2002 U.S. economic structure. In Figure 3-6a-c, we exogenously vary direct emissions from electricity, v_s in Eq. 3-10, i.e. the grid emissions factor in kg CO₂e/kWh divided by 2004 (in 2002\$) electricity prices, in the EIO-LCA model to estimate the embodied emissions per dollar of expenditure, z_s and z_o , for all other goods for a scenario in which the U.S. uniformly reduces its CO₂e emissions from electricity across states. As Figure 3-6a-c shows, the indirect rebound effect in CO₂e emissions for each of the three fuels is sensitive to grid emissions factor (GEF), fuel/energy carrier prices, and gasoline budget shares and income elasticities, with GEFs and prices being the strongest upward drivers of CO₂e indirect rebound effects in percent. CO₂e indirect rebound effects are fairly robust to differences in electricity and natural gas budget shares and income elasticities. It is not surprising that indirect rebound effects from electricity service efficiency vary considerably with GEF, as this is another dimension of the diminishing marginal (emissions abatement) returns to energy efficiency, as the electric grid becomes less GHG-intensive.

A. Indirect Rebound for electricity service efficiency

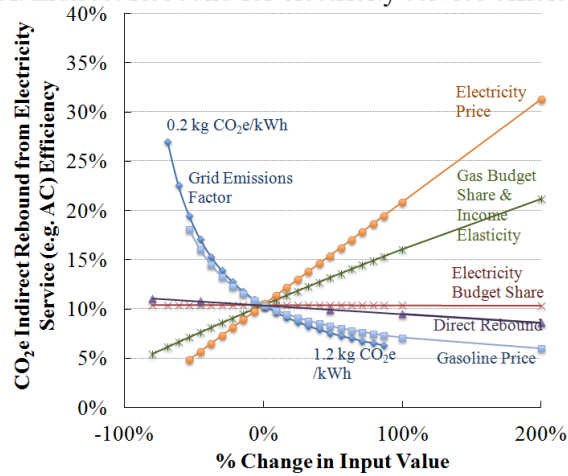

B. Indirect Rebound for natural gas service efficiency

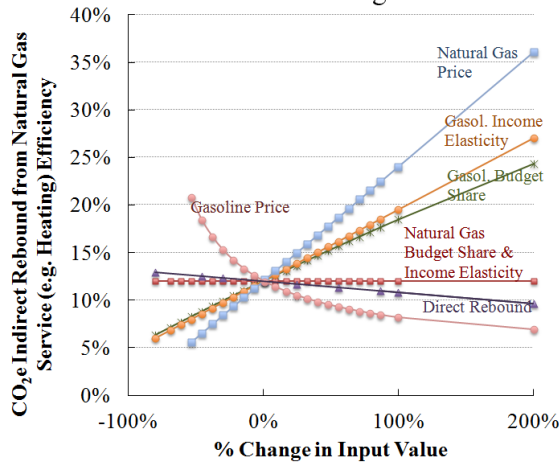

C. Indirect rebound for gasoline service efficiency

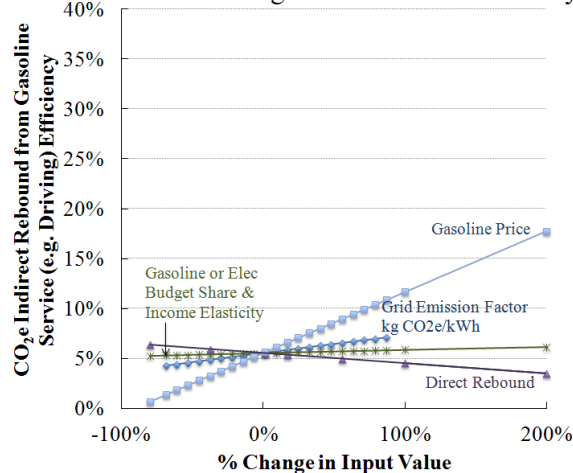

Figure 3-6a-c: Indirect Rebound Effects in CO₂e for efficiency investments reducing average U.S. household expenditures in energy services from (A) electricity, (B) natural gas, and (C) gasoline. Notes: Results assume the 2002 U.S. economic structure and energy prices. Grid emissions factors (GEF) are parametrically varied and used to calculate embodied emissions for other goods in the 2002 EIO-LCA model. Only most sensitive input parameters are shown.

The GEF varies considerably across U.S. states, and gasoline budget shares will vary greatly across regions and individuals, so these sensitivity analyses toward the need for further regional, and microsimulation studies of the indirect rebound effect. The indirect rebound effect also depends on the price of energy commodities relative to other fuels, as higher prices lead to greater energy expenditure savings that can be re-spent on other goods. As the U.S. electric grid mix becomes less GHG-intensive (and perhaps more expensive), a new equilibrium will be reached, perhaps with a lower level of household expenditure on energy, and less-energy intensive industrial processes used to make other goods. However, these sensitivity analyses do not consider changes in household budget shares and firm production functions as fuel or electricity prices change, due to the static, fixed price structure of EIO-LCA.

3.4.4 Direct and Indirect Rebound Effects Vary by Household Income

Figure 3-7a-b demonstrates the variation in the direct and indirect rebound effect by household income, using the 2004 CES summary tables by income (BLS, 2004). Lower-income groups have a slightly higher CO₂e rebound in percentage terms, as expected, since they are furthest away from satiation of energy services (Khazzoom, 1980; Woersdorfer, 2010). The direct and indirect rebound effect for electricity efficiency varies between 35-60% for various income brackets. However, by using electricity price elasticities rather than price elasticities for electricity services, such as heating or lighting, we overestimate the direct rebound (Hanly et al., 2002) and understate the indirect rebound effects for electricity efficiency. The direct and indirect rebound effect for gasoline efficiency, using a price elasticity of driving (Gillingham, 2011) is relatively insensitive to income, and varies between 15-25%.

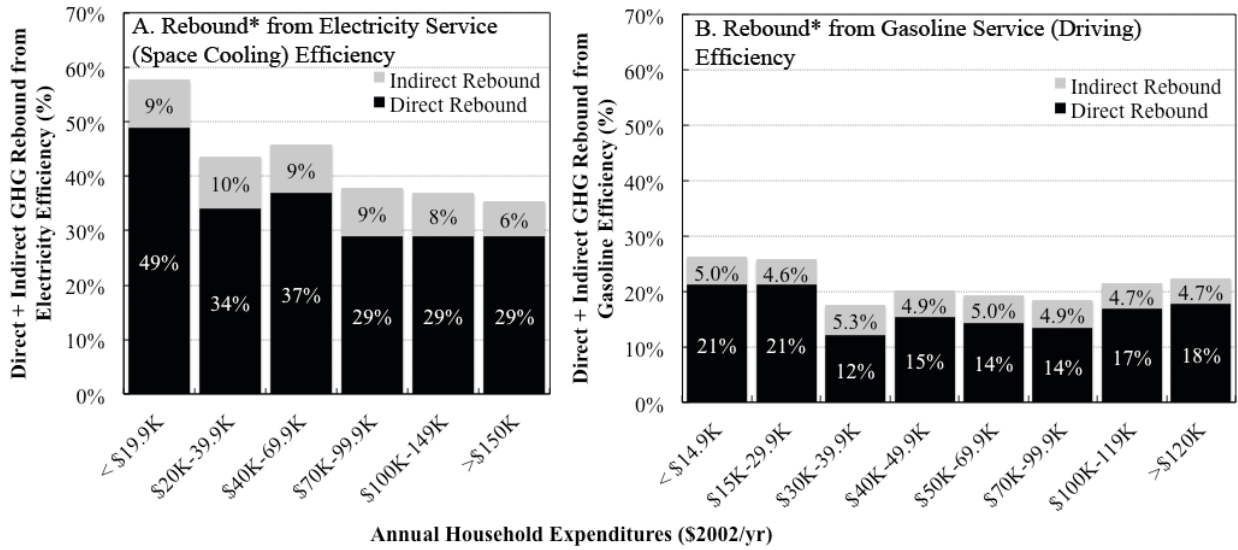

Figure 3-7a-b: Direct and indirect rebound effects in (A) electricity efficiency and (B) gasoline efficiency decline with income. Sources/Notes: *Direct rebound is likely overestimated due to use of own-price elasticity of electricity and gasoline from Reiss and White (2005) and Gillingham (2011). Income elasticities are from Taylor and Houthakker (2010), and budget shares are from 2004 Consumer Expenditure Survey (BLS, 2004).

The income variation of the rebound effect is largely driven by the heterogeneous own-price elasticity estimates for electricity (Reiss and White, 2005) and driving (Gillingham, 2011) by income bracket. Reiss and White’s (2005) own-price elasticity estimates for electricity show greater than the variation by income than Gillingham’s (2011) estimates for driving, thus there is a smaller variation in the rebound effect for gasoline efficiency by income. When constant own-price elasticities are used to estimate rebound effects, the variation by income group is limited, since the differences in GHG emissions per dollar of expenditure by income brackets are minimal.

While lower income groups may have higher direct and indirect rebound effects in the percent, the consequences of these rebound effects, i.e. the difference between potential and actual supply chain CO₂e emissions savings, reveal the importance of the scale of baseline emissions. Figure 3-8 demonstrates that for a 10% reduction in household electricity bills, the direct and indirect rebound in CO₂e emissions are 0.45-0.59 ton CO₂e/yr for households with incomes

greater than \$70,000/yr (in 2002\$), compared to a direct and indirect rebound of 0.37 ton CO₂e/year for the households that would be eligible for energy assistance programs, with incomes less than \$40,000/year. While efficiency investments in low-income households may not reduce electricity demand as much or as cost-effectively as in high-income households, the consequences of higher percent CO₂e rebound effects in low-income households for the climate change problem are relatively small. Instead, efficiency investments in low-income households help to alleviate energy poverty in households that spend over 10% of their budget on energy bills.

Of course a 10% reduction in electricity bills in mid to high income households also yield higher net CO₂e emissions savings of 0.74-1.1kg CO₂e/yr after accounting for direct and indirect rebound effects, compared to net savings of just 0.27-0.48 kg CO₂e/yr for a comparable efficiency investment made in a low-income household. This highlights the need to target energy efficiency programs for the greatest electricity users in a utility service area. Weatherization programs may be more useful for helping low-income households escape energy poverty than for reducing energy consumption and CO₂e emissions.

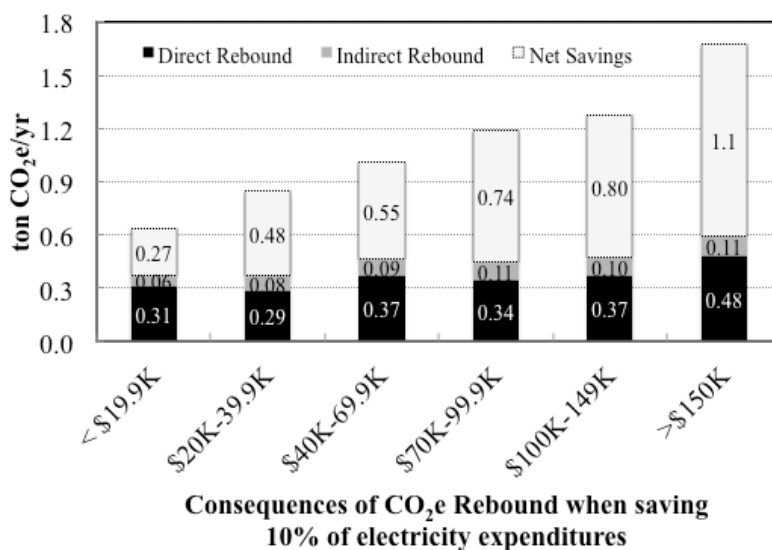

Figure 3-8: Consequences in CO₂e emissions of direct and indirect rebound effects from reducing 10% of annual electricity bills with efficiency for the average household in each income bracket. Sources: 2004 Consumer Expenditure Survey; www.eiolca.net; Reiss and White (2005).

3.5 Discussion and Conclusion

3.5.1 Reliability of the Results

There are several sources of uncertainty that limit the reliability of our results. Among the first are the uncertainties inherent in an EEIO model, reviewed by Lenzen (2000) and Weber and Matthews (2008), which stem from aggregation of sectors, vintage lags between emissions data and IO tables, the linear production function assumption, and changes in structure and production functions of the economy as technology progresses and prices change. The assumption of domestic production of goods (or similar production functions for imports and domestic goods) is particularly problematic since Weber and Matthews (2008) have shown that up to 30% of household carbon footprints can be attributed to imports, using the same 2004 CES data as in this study. If imports are produced in a more carbon-intensive production process than domestically produced goods, this could increase the indirect rebound effect from the estimates provided in this chapter.

In addition, using aggregate CES data masks the considerable variation in spending patterns across households. The income elasticities, direct rebound parameter, and the cross-price elasticities that they imply may not adequately represent the behavior of households in the 2004 CES or future spending patterns. Since the CES data does not contain price information for the various commodities purchased by households, income elasticity estimates obtained from the CES micro data without controlling for price may be biased if incomes and prices for goods correlated. Econometric studies similar to the AIDS model which augment the CES data with price indices, and appliance efficiency trends may obtain better direct rebound parameters and cross-price and income elasticity estimates from microdata, but at the expense of further aggregating sectors according to the availability of price data.

Thirdly, we make a strong assumption of constant cross-price elasticity for other goods to model the indirect rebound effect. This approach could be complemented with (AIDS-type) econometric studies and other approaches to constructing cross price elasticities in order to understand the cases in which substitution effects are important for empirical estimates of the indirect rebound effect. Sensitivity analyses in this study indicate the relationship between home energy demand and vehicle and other travel is of particular importance as gasoline price elasticities and budget shares strongly influence our indirect rebound effect estimates, as does the generation mix of the U.S. electric grid. The fairly low indirect rebound estimates found in this study may be due to the high CO₂e intensity of the U.S. electricity grid mix compared with Europe, where most of the previous indirect rebound studies (see Table 3-3 in the SI) have taken place.

3.5.2 Relevance of Results

Contrary to Brannlund et al. (2007), this study shows that residential energy efficiency investments do lead to a reduction in primary energy consumption or CO₂e, NO_x, or SO₂ emissions – there is no evidence of backfire or rebound > 100% -- while direct rebound effects are on the order of 10%, as found in prior studies in the U.S. Backfire only occurs when direct rebound effects are close to 100% *and* U.S. households exhibit high (> 2) income elasticities for driving, at 2002 prices, electric grid mix, and U.S. economic structure. Thus, currently energy efficiency policies in the U.S. are effective at reducing supply chain energy and emissions. In most cases, improving vehicle efficiency to save on gasoline expenditures leads to the lowest rebound effects, due to lower indirect rebound effects compared to other types of efficiency and the larger budget share for gasoline in most households. Since our analysis ignores the effect of

higher capital costs for efficient appliances or vehicles, our results tend to overestimate the extent of the direct and indirect rebound effects (Henly et al., 1987).

We also show that the proportional re-spending case, typically used in industrial ecology studies of the rebound effect, is fairly accurate for natural gas efficiency, may underestimate the indirect rebound effect for electricity efficiency, and overestimate the indirect rebound effect for gasoline efficiency, due to the differences in patterns of spending implied by income elasticities. Income elasticity spending appears to be a good representation of re-spending effects, in situations in which the direct rebound effect is small ($< 25\%$). The substitution effects implied by the cross-price elasticity model developed in this chapter, are small, except at high direct rebound effects that may apply for low-income households or in developing countries.

Furthermore, we have shown that direct and indirect rebound effects are inversely proportional, so that larger the direct rebound, the smaller the indirect rebound. As household incomes rise, the direct rebound effect is expected to decline as households reach satiation of existing energy services (Small and van Dender, 2005). As energy prices increase or the U.S. electric grid mix switches to less carbon-intensive resources, our results show that the indirect rebound effect will increase. It remains to be seen which effect dominates over time for electricity, natural gas, and gasoline efficiency. We also find that a focus on the rebound effect in percentage terms is highly misleading in regions with different energy prices and different baseline levels of energy consumption and income, and should be augmented with estimates of the consequences of the rebound effect in primary energy consumption or emissions.

Households experience a rebound effect because they can achieve greater economic utility from increased demand for energy services and other goods. If the rebound effect lowers social welfare, this is due to the externalities imposed by energy consumption in general and could be

addressed with carbon or emissions taxes, cap-and-trade policies, or other mechanisms to price the externality at the social cost. Van den bergh (2010) argues that emissions trading schemes, which cap energy consumption and emissions, are more useful than carbon taxes given the possibility of rebound effects. However, policies explicitly designed to counter rebound effects may not be necessary if externalities, such as carbon dioxide, were priced at the social cost, so that any rebound effects that occur would strictly increase the household's welfare.

An important consideration from the policymaker or utility manager's perspective is the cost-effectiveness of energy efficiency relative to investments in new energy supply or pollution control equipment in meeting reliable energy supply, reduced air pollution, and climate change mitigation goals. Further research on the cost-effectiveness of energy efficiency relative to low-carbon energy supply can guide decisions about the optimal level of investment in these technologies to meet climate change mitigation, energy security, and air pollution reduction goals.

3.6 References

- Alberini, A., Gans, W., and Velez-Lopez, D., 2011. Residential Consumption of Gas and Electricity in the U.S.: the Role of Price and Income. *Nota Di Lavoro: Sustainable Development Series*. Carraro, C., Ed.
- Alfredsson, E.C., 2004. 'Green' consumption - no solution for climate change. *Energy* 29, 513-524.
- Allan, G, Hanley, N., McGregor, P. G., Swales, J. K., and Turner, K., 2006. The Macroeconomic Rebound Effect and the UK Economy. Final Report to the Department of Environment Food and Rural Affairs.
- Allan, G., Gilmartin, M., and Turner, K., 2007. UKERC Review of Evidence for the Rebound Effect. Technical Report 4: Computable general equilibrium modeling studies. Working Paper. UK Energy Research Centre.
- American Council for an Energy Efficient Economy (ACEEE), 2011a. Energy Efficiency Resource Standards. Available at: <http://www.aceee.org/topics/eers>
- American Council for an Energy Efficient Economy (ACEEE), 2011b. American Recovery and Reinvestment Act of 2009. Available at: <http://www.aceee.org/topics/arra>
- Azevedo, I.L., 2009. Energy Efficiency in the U.S. Residential Sector: An Engineering and Economic Assessment of Opportunities for Large Energy Savings and Greenhouse Gas Emissions Reductions. Ph.D. dissertation, Department of Engineering and Public Policy, Carnegie Mellon University, Pittsburgh, PA.

- Azevedo, I. L., Morgan, G. M., and Apt, J., 2011. Residential and Regional Electricity Consumption in the U.S. and E.U.: How much will higher prices reduce CO2 Emissions? *The Electricity Journal* 24, 21-29.
- Berkhout, P. H. G., Muskens, J. C., and Velthuisen, J. W., 2000. Defining the rebound effect. *Energy Policy* 28, 425-432.
- Biesiot, W., and Noorman, K. J., 1999. Energy requirements of household consumption: a case study of the Netherlands. *Ecological Economics* 28, 367-383.
- Binswanger, M., 2001. "Technological progress and sustainable development: what about the rebound effect?" *Ecological Economics* 36, 119-132.
- Blundell, R., 1988. Consumer Behavior: Theory and Empirical Evidence --A Survey. *The Economic Journal* 98, 16-65.
- Brannlund, R., Ghalwash, T., and Norstrom, J., 2007. Increased Energy Efficiency and the Rebound Effect: Effects on Consumption and Emissions. *Energy Economics* 29, 1-17.
- Brookes, L., 1990. The greenhouse effect: the fallacies in the energy efficiency solution. *Energy Policy* 18, 199-201.
- Brookes, L., 2000. Energy efficiency fallacies revisited. *Energy Policy* 28, 355-366.
- Bureau of Labor Statistics (BLS), 2004. Consumer Expenditure Survey Tables.
- BLS. Consumer price index, 2002-2004. Tables and Microdata
<http://www.bls.gov/cpi/tables.htm> (Accessed June 16, 2012).
- BLS., 2012. "Consumer Expenditure Survey, Frequently Asked Questions." Accessed 1 Mar 2012. <http://www.bls.gov/cex/csxfaq.htm#q21>.
- Bureau of Transportation Statistics (BTS), 2012. Table 1-11: Number of U.S. Aircraft, Vehicles, Vessels, and Other Conveyances.
http://www.bts.gov/publications/national_transportation_statistics/html/table_01_11.html
- Table 4-23: Average Fuel Efficiency of U.S. Light Duty Vehicles.
http://www.bts.gov/publications/national_transportation_statistics/html/table_04_23.html
- Carlsson-Kanyama, A., R. Engström and R. Kok, 2005. Indirect and Direct Energy Requirements of City Households in Sweden: Options for Reduction, Lessons from Modeling. *Journal of Industrial Ecology* 9(1): 221-236.
- Carnegie Mellon Green Design Institute., 2011. "Economic Input-Output Lifecycle Assessment Model." www.eiolca.net.
- Chalkley, A. M., Billett, E., and Harrison, D., 2001. An investigation of the possible extent of the Re-spending Rebound Effect in the sphere of consumer products. *The Journal of Sustainable Product Design* 1, 163-170.
- Chitnis, M., Sorrell, S., Druckman, A., First, S., and Jackson, T., 2012. Estimating direct and indirect rebound effects for UK households. Sustainable Lifestyles Research Group Working Paper 01-12.<
http://www.sustainablelifestyles.ac.uk/sites/default/files/projectdocs/estimating_direct_and_in_direct_rebound.pdf>
- Dahl, C. and Sterner, T., 1991. Analysing gasoline demand elasticities: a survey. *Energy Economics* 13. 203-210.
- Davis, L., 2008. "Durable goods and residential demand for energy and water: evidence from a field trial." *RAND Journal of Economics* 39, 530-546.
- Davis, L., Fuchs, A., and Gertler, P., 2012. "Cash for Coolers." National Bureau of Economic Research Working Paper #18044.

- Deaton, A. and Muellbauer, J., 1980. An almost ideal demand system. *The American Economic Review* 70, 312-326.
- Dinan, T. and Trumble, D., 1989. Temperature takeback in the Hood Review conservation project. *Energy and Buildings* 13, 39-50.
- Druckman, A., Chitnis, M., Sorrell, S., and Jackson, T., 2011. Missing carbon reductions? Exploring rebound and backfire in U.K households. *Energy Policy* 39, 3572-3581.
- Dubin, J., Miedema, A., and Chandran, R., 1986. Price Effects of Energy-Efficient Technologies: A Study of Residential Demand for Heating and Cooling. *The RAND Journal of Economics* 17, 310-325.
- Dubin, J. and McFadden, D., 1983. A Heating and Cooling Load Model for Single-Family Detached Dwellings in Energy Survey Data. Caltech Social Science Working Paper 469.
- Energy Information Administration (EIA), 2012. Annual Energy Outlook (AEO), Table A-4. http://www.eia.gov/forecasts/aeo/er/early_consumption.cfm
- EIA, 2011. "Voluntary Reporting of Greenhouse Gases Program." Tables 1-2. <http://www.eia.gov/oiaf/1605/coefficients.html>
- Freire-Gonzalez, J. 2011. Methods to empirically estimate direct and indirect rebound effect of energy-saving technological changes in households. *Ecological Modelling* 223, 32-40.
- Frondel, M., Ritter, N., Vance, C., 2010. Heterogeneity in the Rebound Effect. Further Evidence for Germany. *Ruhr Economic Papers*, No. 227.
- Gillingham, K., Newell, R. G., and Palmer, K., 2009. Energy Efficiency Economics and Policy. *Annual Review of Resource Economics* 1, 597-619.
- Gillingham, K., 2011. How Do Consumers Respond to Gasoline Price Shocks? Heterogeneity in Vehicle Choice and Driving Behavior. *Empirical Methods in Energy Economics Proceedings*. Dallas, TX.
- Girod, B. and de Haan, P., 2008. Mental rebound. Rebound research report. No. 3. ETH Zurich, Institute for Environmental Decisions (IED). www.uns.ethz.ch/res/irl/emdm/publications/berichte. Zurich
- Girod, B., de Haan, P., 2010. More or better? A model for changes in household greenhouse gas emissions due to higher income. *Journal of Industrial Ecology* 14, 31-49.
- Goedkoop, M., van Halen, C., te Riele, H., and Rommens, P. Product service systems, ecological and economics basics. PricewaterhouseCoopers: The Hague, Netherlands, 1999.
- Greene, D.L., 2011. Uncertainty, loss aversion and markets for energy efficiency. *Energy Economics* 33, 608-616.
- Greene, D.L., 2012. Rebound 2007: Analysis of U.S. light-duty vehicle travel statistics. *Energy Policy* 41, 14-28.
- Greening, L. A., Greene, D. L., and Difiglio, C., 2000. Energy efficiency and consumption -- the rebound effect -- a survey. *Energy Policy* 28, 389-401.
- Guerra, A. and Sancho, F., 2010. Rethinking economy-wide rebound measures: An unbiased proposal. *Energy Policy* 38, 6684-6694.
- Hanly, M., Dargay, J.M., Goodwin, P.B., 2002. Review of income and price elasticities in the demand for road traffic. Final report to the DTLR under Contract number PPAD 9/65/93, ESRC Transport Studies Unit. University College London, London.
- Haughton J. and S. Sarkar, 1996. Gasoline Tax as a Corrective tax: Estimates for the United States, 1970-1991. *Energy Journal* 17, 103-126.
- Hendrickson, C. T., Lave, L. B., Matthews, H. S., 2006. Environmental Life Cycle Assessment of Goods and Services: An Input-Output Approach. RFF Press; Washington, DC.

- Henly, J, Ruderman, H, and Levine, M., 1988. Energy Saving Resulting from Adoption of More Efficient Appliances: A Follow-up. *Energy Journal* 9, 163-170.
- Hirst, E., White, D., and Goeltz, R., 1985. Indoor temperature changes in retrofit homes. *Energy* 10, 861-870.
- Howarth, R. and Sanstad, A., 1995. Discount rates and energy efficiency. *Contemporary Economic Policy* XIII, 101-109.
- Howarth, R., 1997. Energy Efficiency and Economic Growth. *Contemporary Economic Policy* XV, 1-9.
- Hsueh, L., Gerner, J.L., 1993. Effect of thermal improvements in housing on residential energy demand. *Journal of Consumer Affairs* 27, 87-105.
- Hunt, L. and Ryan, D., 2011. Catching on the rebound: Determination of rebound effects in energy economics. *Empirical Methods in Energy Economics* conference paper: Dallas, TX.
- Hunt, L. and Ryan, D., 2012. Are findings of price asymmetry in energy demand models due to model misspecification? *Empirical Methods in Energy Economics* conference paper: Berlin, Germany.
- International Energy Agency (IEA), 2009. *World Energy Outlook*. Figure 5-8.
- Jaffe, A. B. and Stavins, R. N., 1994. The energy efficiency gap: What does it mean? *Energy Policy* 22, 804-810.
- Jalas, M., 2002. A time-use perspective on the materials intensity of consumption. *Ecological Economics* 41, 109-123.
- Khazzoom, J.D., 1980. Economic implications of mandated efficiency in standards for household appliances. *Energy Journal* 1, 21-40.
- Kratena, K., Wuger, M., 2008. The full impact of energy efficiency on household's energy demand. *Austrian Institute of Economic Research (WIFO)*.
- Klein, Y.L., 1987. An econometric model of the joint production and consumption of residential space heat. *Southern Economic Journal* 55, 351-359.
- Kok, R., Benders, R., Moll, H., 2006. Measuring and environmental load of household consumption using some methods based on input-output energy analysis: A comparison of methods and a discussion of results. *Energy Policy* 34, 2744-2761.
- Lenzen, M., 2000. Errors in conventional and input-output based life-cycle inventories. *Journal of Industrial Ecology* 4, 127-148.
- Lenzen, M., Dey, C.J., 2002. Economic, energy and greenhouse emissions impacts of some consumer choice, technology and government outlay options. *Energ Econ* 24, 377- 403.
- McKinsey and Company, 2009. *Unlocking Energy Efficiency in the U.S. Economy*. McKinsey Global Institute.
- Meier, A., 1982. *Supply Curves of Conserved Energy*. PhD. Thesis, Energy and Resource Group, University of California, Berkeley, CA.
- Mizobuchi, K., 2008. An empirical study on the rebound effect considering capital costs. *Energy Economics* 30, 2486-2516.
- Murray, C.K., 2011. Income dependent direct and indirect rebound effects from 'green' consumption choices in Australia. *Munich Personal RPEC archive, MPRA Paper No. 34973*, Munich.
- Nässén, J. and J. Holmberg, 2009. Quantifying the rebound effects of energy efficiency improvements and energy conserving behaviour in Sweden. *Energy Efficiency* 2, 2201-2231.
- Nicholson, W., 2005. *Microeconomic Theory: Basic Principles and Extensions*. Ninth Edition. Thomson/South-Western; Mason, Ohio.

- Reiss, P. and White, W., 2005. Household Electricity Demand, Revisited. *Review of Economic Studies* 72, 853-883.
- Roy, J., 2000. The rebound effect: some empirical evidence from India. *Energy Policy* 28, 433-438.
- Sanstad, A., Blumstein, C., and Stoft, S., 1995. How high are option values in energy-efficiency investments. *Energy Policy* 23, 739-743.
- Saunders, H.D., 1992. A view from the macro side: rebound, backfire, and Khazoom-Brookes. *Energy Policy* 28, 439-449.
- Saunders, H. D., 2000. A view from the macro side: rebound, backfire, and Khazoom-Brookes. *Energy Policy* 28, 439-449.
- Saunders, H. D., 2008. Fuel conserving (and using) production functions. *Energy Economics* 30, 2184-2235.
- Saunders, H. D., 2010. Historical evidence for energy consumption rebound in 30 U.S. sectors and a toolkit for rebound analysts. The Breakthrough Institute Blog. [http://thebreakthrough.org/blog/Historical Evidence Article 11-11-10.pdf](http://thebreakthrough.org/blog/Historical%20Evidence%20Article%2011-11-10.pdf).
- Schipper, L. and Grubb, M., 2000. On the rebound? Feedback between energy intensities and energy uses in IEA countries. *Energy Policy* 28, 367-388.
- Schwartz, P.M., Taylor, T.N., 1995. Cold hands, warm hearth?: climate, net takeback, and household comfort. *Energy Journal* 16, 41-54.
- Shefrin, H. H. and Thaler, R. H., 1988. The behavioral life-cycle hypothesis *Economic Inquiry* 26, 609-643.
- Small, K, van Dender, K., 2005. The Effect of Improved Fuel Economy on Vehicle Miles Traveled: Estimating the Rebound Effect Using U.S. State Data, 1966-2001. University of California Energy Institute: *Energy Policy and Economics* 014.
- Small, K. and Van Dender, K., 2007. Fuel Efficiency and Motor Vehicle Travel: The Declining Rebound Effect. *Energy Journal* 28, 25-51.
- Sorrell, S. (2009). Jevon's Paradox Revisited: The evidence for backfire from improved efficiency. *Energy Policy* 37, 1456-1469.
- Sorrell, S., Dimitropoulos, J., and Sommerville, M., 2009. Empirical estimates of the direct rebound effect: A review. *Energy Policy* 37. 1356-1371.
- Sorrell, S. and Dimitropoulos, J., 2008. The rebound effect: Microeconomic definitions, limitations and extensions. *Ecological Economics* 65, 636-649.
- Sorrell, S., 2007. The Rebound Effect: an assessment of the evidence for economy-wide energy savings from improved energy efficiency. UK Energy Research Centre Technical Report.
- Sorrell, S., 2004. *The Economics of Energy Efficiency: Barriers to Cost-Effective Investment*. Book News, Inc; Portland, OR.
- Spielmann, M, Scholz, R. W., 2005. Life cycle inventories of transport services. *Intl Journal of Life Cycle Assessment* 10, 85-94.
- Sudarshan, A., 2011. Why is per-capita residential energy consumption in California so low? Proceedings of the International Association for Energy Economics Meeting. Stockholm, Sweden.
- Tarr, D., 1990. A Modified Cournot aggregation condition for obtaining estimates of cross-elasticities of demand. *Eastern Economic Journal* XVI, 257-264.
- Taylor, L. D. and Houthakker, H.S., 2010. *Consumer Demand in the United States: Prices, Income, and Consumption Behavior*. Third Edition. Springer; New York, NY.

- Thiesen, J., Christiansen, T.S., Kristensen, T.G., Andersen, R.D., Brunoe, B., Greger- sen, T.K., Thrane, M., Weidema, B.P., 2008. Rebound effects of price differences. *International Journal of Life Cycle Assessment* 13, 104–114.
- Turner, K., 2009. Negative rebound and disinvestment effects in response to an improvement in energy efficiency in the U.K. economy. *Energy Economics* 31, 648-666.
- Van den Bergh, J., 2011. Energy Conservation More Effective With Rebound Policy. *Environmental Resource Economics* 48, 43-58.
- Vine, E., Misuriello, H., and Hopkins, M. E., 1994. A Research Agenda for Demand-Side Management Impact Measurement. *Energy* 11, 1103-1111.
- Wang, H., Zhou, P., and Zhou, D. Q. , 2012. An empirical study of the direct rebound effect for passenger transport in urban China. *Energy Economics* 34, 452-460.
- Weber, C., and Matthews, H. S., 2008. Quantifying the global and distributional aspects of American household carbon footprint. *Ecological Economics* 66, 379-391.
- Weber, C. L., Jaramillo, P, Marriott, J., and Samaras, C., 2010. Life-cycle Assessment and Grid Electricity: What do we know and what can we know? *Environmental Science and Technology* 44, 1895-1901.
- Wei, T., 2010. A general equilibrium view of global rebound effects. *Energy Economics* 32, 661-672.
- Wirl, F., 1997. *The Economics of Conservation Programs*. Kluwer Academic Publishers; Boston, MA.
- Wörsdorfer, J.S., 2010. Consumer needs and their satiation properties as drivers of the rebound effect. The case of energy-efficient washing machines. *Papers on Economics & Evolution* No. 1016. Jena: Max Planck Institute of Economics, Evolutionary Economics Group.

3.7 Supporting Information

3.7.1 Literature Review of Direct and Indirect Rebound Studies

Table 3-2: Selected review of U.S. direct rebound studies using energy services model

Author (year)	Method	Sample Size	Sample Years	Region	Direct Rebound Estimate	Notes
<i>Space heating/Electric end-uses</i>						
Hirst (1985)	pre vs. post measurements	79	1981-1983	Pacific Northwest U.S.	10-15%	control group, low income groups have higher take-back
Dubin et al. (1986)	energy service price elasticity	214-396 (cool), 252 (heat)	1982-1983	Florida	8-12%	electric space heating and cooling
Dinan and Trumble (1989)	pre vs. post thermostat settings	254	1984-1986	Oregon	3%	only 5% of gap between engineering estimates and actual savings is due to behavior change (thermostat changes)
Schwartz and Taylor (1995)	energy service price elasticity	~270	1984-1985	9 census divisions	1-3%	electric space heating
Davis (2008)	energy price elasticity, controlling for self-selection in field trial		1997	Bern, Kansas	6%	Compared electricity and water use from residential clothes washers in field trial; controlling for unobserved factors
<i>Transport</i>						
Haughton and Sarkar (1996)	VMT elasticity of fuel intensity (inverse of fuel economy)		1970-1991		16% (SR) and 22% (LR)	CAFE standard variable is correlated with historical high price variable

Author (year)	Method	Sample Size	Sample Years	Region	Direct Rebound Estimate	Notes
Small and van Dender (2007)	VMT elasticity of fuel economy	1734	1966-2001	US states panel	5% (SR) 22% (LR)	declining with income and over time
Gillingham (2011)	VMT elasticity of fuel economy VMT elasticity of gas prices	> 1 million	2000-2006	California households/ vehicles	9% 15%	structural model for vehicle choice and utilization and quantile regression by income
Greene (2012)	VMT elasticity of fuel cost per mile	51	1970s-2007	US states aggregate time series	3% (SR) 13% (LR)	time series regression, fuel economy variation is small

Table 3-3: Literature Review of Direct and Indirect Rebound Studies

Author	Sample Period	Sector Number	Country	Action	Re-spending Scenario	Direct Rebound Parameter	Embodied Energy	Direct Rebound	Indirect Rebound, Energy/GHG
Lenzen and Dey (2002)	1995	150	Australia	Efficiency, behavior change	proportional spending	no direct effect	Scope 1-3	NA	45-50% for GHGs, 112-123% energy consumption
Alfredsson (2004)	1996	300	Sweden	Behavior change (food, travel, utilities)	Income elasticity	energy service/price elasticity	Scope 1-3	10-30%	14-300%
Brannlund et al. (2007)	1980-1997	13	Sweden	Efficiency in Heating, Transport,	Linear AIDS	energy price elasticity	Scope 1-2	15%	106%

Author	Sample Period	Sector Number	Country	Action	Re-spending Scenario	Direct Rebound Parameter	Embodied Energy	Direct Rebound	Indirect Rebound, Energy/GHG
				Both					
Mizobuchi (2008)	1990-1998	13	Japan	Efficiency in Heating, Transport, Both	Linear AIDS	energy price elasticity	Scope 1-2	111% electricity, 5% transport	84% (electricity), 22% (gasoline)
Thiesen et al. (2008)	2001-2003	34	Denmark	Behavior change & price change (food, i.e. cheese)	Slopes in spending, by income	no direct effect	Scope 1-3	NA	NA
Nassen and Holmberg (2009)	2003	42	Sweden	Efficiency in space heating, appliances, and transport	income elasticity	energy service price elasticity	Scope 1-3	9 to 22%	-1 to 26%
Kratena and Wuger (2010)	1972-2005	6	US	Efficiency	Quadratic AIDS	energy service price elasticity	no	14% (gas) to 19% (elec)	-57% (elec) to 71% (gasoline)
Girod and de Haan (2010)	2002-2005	450	Switzerland	Behavior change (food)	Income elasticity	no direct effect	Scope 1-3	NA	53%
Freire-Gonzalez (2011)	2000-2008, 2005 IO Tables	31	Catalonia	Efficiency	income elasticity & proportional spending	energy price elasticity	Scope 1-3	36% (SR) 49% (LR)	20% (SR) 16% (LR)
Murray (2011)	2003-2004	36	Australia	Efficiency	income elasticity	no direct effect	Scope 1-3	NA	5-40%

Author	Sample Period	Sector Number	Country	Action	Re-spending Scenario	Direct Rebound Parameter	Embodied Energy	Direct Rebound	Indirect Rebound, Energy/GHG
Druckman et al. (2011)	1992-2004, 2008 elasticities	16	UK	Behavior change/ conservation	income elasticity	no direct effect	Scope 1-3	NA	7-51%
Chitnis et al. (2012)	2004	16	UK	Efficiency, Investments, and behavior change	income elasticity	no direct effect	Scope 1-3	NA	3-11% with capital costs, 15-20% without capital costs
Wang et al. (2012)	1994-2009	7	China	Personal transport efficiency	Linear AIDS	energy price elasticity	none	2-246%	NA

Notes: Adapted and expanded from Chitnis et al. (2012).

3.7.2 Slutsky Model of Price Elasticities and Rebound Effects

The Slutsky model of consumer demand (Nicholson, 2005) in response to price changes assumes that the minimum expenditure to achieve a utility level, U is:

$$\min_Y Y(P_S, P_O, U) \quad 3-16$$

The compensated energy service demand, $S|_U$, is defined as the level of energy service consumption required by the household to achieve utility level U .

$$S|_U = S(P_S, P_O, Y(P_S, P_O, U)) \quad 3-17$$

Then, the change in compensated energy service demand in response to a change in energy service prices is given by

$$\left. \frac{\partial S}{\partial P_S} \right|_U = \frac{\partial S(P_S, P_O, Y(P_S, P_O, U))}{\partial P_S} = \frac{\partial S}{\partial P_S} + \frac{\partial S}{\partial Y} \frac{\partial Y}{\partial P_S} \quad 3-18$$

After rearranging the terms, using the assumption that expenditures (including savings as a category) equal income, $\frac{\partial S}{\partial Y} = \frac{\partial S}{\partial I}$, and using the envelope theorem (Nicholson, 2005) to show that

$\frac{\partial Y}{\partial P_S} = S$, we obtain the Slutsky decomposition:

$$\frac{\partial S}{\partial P_S} = \left. \frac{\partial S}{\partial P_S} \right|_U - S \frac{\partial S}{\partial I} \quad 3-19$$

If we multiply by $P_S I / S I$, and note that $P_S S / I =$ share of income spent on energy services, w_S , we obtain the Slutsky decomposition in elasticity terms, where the energy service price elasticity is the (absolute value) measure of the direct rebound effect.

$$\frac{\partial S}{\partial P_s} \frac{P_s I}{S I} = \frac{\partial S}{\partial P_s} \frac{P_s I}{S I} \Big|_U - S \frac{\partial S}{\partial I} \frac{P_s I}{S I}$$

$$\frac{\partial S}{\partial P_s} \frac{P_s}{S} = \frac{\partial S}{\partial P_s} \frac{P_s}{S} \Big|_U - \frac{P_s S}{I} \frac{\partial S}{\partial I} \frac{I}{S}$$

$$\eta_{S,P_s} = \eta_{S,P_s} \Big|_U - w_S \eta_{S,I} \quad 3-20$$

We can use similar reasoning to examine the change in “other goods” demand, O , with respect to a change in energy service prices, to obtain a similar decomposition of cross-price elasticities of the demand for other goods with respect to the price of energy services, shown in Eq. 3-21. The cross-price elasticity of the demand for other goods with respect to energy services is one aspect of the indirect rebound effect defined by Sorrell and Dimitropoulos (2008). The interlinkage between the demand for energy services, S , and other goods, O , implied by the two Slutsky relations in Eq. 3-20 and Eq. 3-21 are illustrated in Figure 3-9.

$$\eta_{O,P_s} = \eta_{O,P_s} \Big|_U - w_S \eta_{O,I} \quad 3-21$$

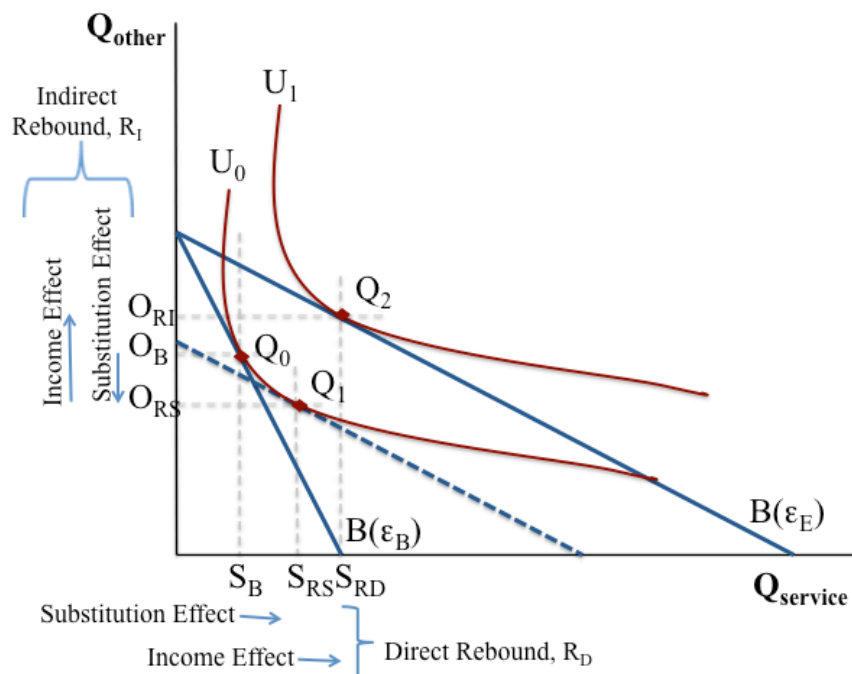

Figure 3-9: Slutsky Decomposition Analysis of the Rebound Effect. The direct and indirect rebound effects can both be decomposed into substitution and income effects in response to a change in the price of energy services with an efficiency investment.

In Figure 3-9, the household's original budget constraint, $B(\epsilon_B)$, which is a function of appliance efficiency, moves outward to $B(\epsilon_E)$ with a decrease in the price of energy services implied by investment in an appliance with higher efficiency, $\epsilon_E > \epsilon_B$. This implies that the household's utility maximizing consumption bundle changes from $Q_0(S_B, O_B)$ at utility level U_0 , to $Q_2(S_{RD}, O_{RI})$ so that the household is able to achieve a higher utility level, U_1 . The change in demand for energy services and other goods can be decomposed into the substitution and income effects, where the substitution effect leads to a change in demand for energy services and other goods holding utility constant, and the income effect leads to an increase in demand for all (non-inferior) goods and services to achieve a higher utility level. The net change in the demand for energy services is the direct rebound effect, Thus, the direct and indirect rebound effects are both due to the substitution and income effects arising from the change in the price of energy services with an efficiency investment, in contrast to previous qualitative definitions (Sorrell et al., 2007;

Berkhout et al, 2000; Binswanger, 2001), which simply equate the direct rebound effect with the substitution effect and the indirect rebound effect with the income effect.

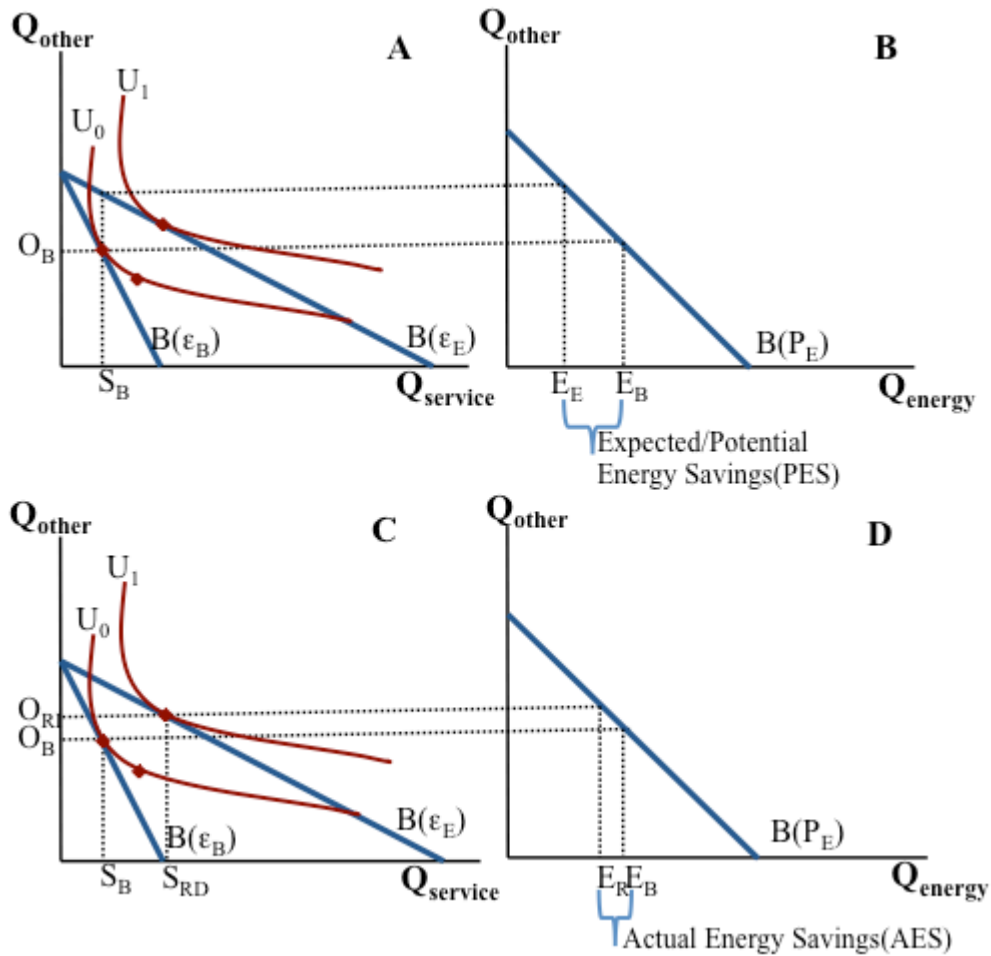

Figure 3-10a-d: Rebound in Energy Services vs. Energy Consumption. Graphs A, C show how an increase in demand for energy services due to the lower price of energy services can still lead to a net reduction of energy consumption, in Graphs B, D, with a rebound effect less than 100%.

The implications of the direct and indirect rebound effect on energy consumption are shown in Figure 3-10, where the household's budget is a function of energy price, P_E , which is assumed to be constant, and other prices. A change in the demand for energy services due to the lower price of energy services with an efficiency investment, leads to a change in the demand for energy. When the rebound effect is less than 100%, an increase in demand for energy services can still lead to a decrease in energy consumption.

3.7.3 Derivation of Indirect Rebound by Construction of Cross-Price Elasticities

Our model of the indirect rebound effect relies on the assumption that each fuel provides a single energy service, i.e. all electric-end uses have a price elasticity similar to that of space-cooling; all natural gas end-uses have a price elasticity similar to that of space heating; all gasoline end-uses have a price elasticity similar to that of driving. The single service per fuel assumption implies that the share of expenditures spent in a fuel is equal to the share of expenditures spent in the energy service, $w_e = w_s$. Using the single service per fuel assumption, Engel aggregation also implies that the income elasticity of the demand for an energy service is equal to the income elasticity of the demand for energy, $\eta_{S,I} = \eta_{E,I}$.

To derive cross-price elasticities of the demand for non-energy services with respect to the price of energy services, we start with the Cournot Aggregation property in elasticity form, which assumes that the price of energy is uncorrelated with other prices.

$$w_S \eta_{S,P_S} + \sum_{O=1;\neq S}^n w_O \eta_{O,P_S} = -w_S \quad 3-22$$

We then substitute the Slutsky decomposition for the energy price elasticity and cross-price elasticities, Eq. 3-20 and Eq. 3-21, into Eq. 3-22, using the single service per fuel assumption to obtain Eq. 3-23.

$$w_S \left[\eta_{S,P_S} \Big|_U - w_S \eta_{S,I} \right] + \sum_{O=1;\neq S}^n w_O \left[\eta_{O,P_S} \Big|_U - w_S \eta_{O,I} \right] = -w_S \quad 3-23$$

Gathering the income and energy service-price elasticity terms together, we use the Engel aggregation property that $\sum_{a=1}^n w_a \eta_{a,I} = 1$, in the second bracketed term in Eq. 3-24, to obtain Eq. 3-25.

$$\left[w_S \eta_{S,P_S} \Big|_U + \sum_{O=1;\neq S}^n w_O \eta_{O,P_S} \Big|_U \right] - w_S \left[w_S \eta_{S,I} \Big|_U + \sum_{O=1;\neq S}^n w_O \eta_{O,I} \Big|_U \right] = -w_S \quad 3-24$$

$$\left[w_S \eta_{S,P_S} \Big|_U + \sum_{O=1;\neq S}^n w_O \eta_{O,P_S} \Big|_U \right] = 0 \quad 3-25$$

We assume that all compensated (constant utility) cross-price elasticities with respect to the price of energy are equal, which is generally not the case; see for example, Blundell (1990), for the U.K. context. However, this assumption is useful to illustrate the dependency between the indirect and direct rebound effect. See Tarr (1990) for alternative methods of constructing cross-price elasticities for closely related substitutes, such as natural gas and fuel oil. We then solve for the compensated cross-price elasticity:

$$\eta_{O,P_S} \Big|_U = \frac{-w_S \eta_{S,P_S} \Big|_U}{\sum_{O=1;\neq S}^n w_O} = \frac{-w_S (\eta_{S,P_S} + w_S \eta_{S,I})}{1 - w_S} \quad 3-26$$

By substituting the above expression for compensated cross-price elasticity for other goods into Eq. 3-21, we construct uncompensated cross-price elasticities for other goods in terms of Eq. 3-26 and income elasticities, in Eq. 3-27.

$$\eta_{O,P_S} = \frac{-w_S (\eta_{S,P_S} + w_S \eta_{S,I})}{1 - w_S} - w_S \eta_{O,I} \quad 3-27$$

3.7.4 Embodied Primary Energy and Emissions Intensities

Table 3-4: Primary energy-, CO₂e-, NO_x-, and SO₂-intensities, E_s and E_o, per dollar of household expenditure for 13 categories.

Expenditure Category	2004 Annual Expenditures		MJ/\$	kg	g	g
	(02\$)	w _o		CO ₂ e/\$	NO _x /\$	SO ₂ /\$
Food, Bev	3,227	8%	11	1.3	2.6	1.8
Shelter, Furniture, Maint	6,381	15%	3	0.2	0.6	0.7
Appliances	1,036	3%	7	0.4	1.3	1.1
Electricity	1,014	2%	111	9.4	18.1	36.8
Natural Gas, Fuel Oil	519	1%	142	8.1	8.6	3.4
Other Utilities	1,704	4%	6	0.6	0.9	1.0
Gasoline	1,575	4%	109	7.6	24.3	7.4
Transportation Equip & Fees	4,696	11%	7	0.5	1.5	1.2
Public Transit	80	0%	32	1.9	18.9	2.0
Air, Water Transportation	312	1%	31	2.1	8.0	3.2
Health Care	1,625	4%	4	0.3	0.8	0.7
Financial Services	8,370	20%	2	0.1	0.3	0.3
Miscellaneous	10,792	26%	7	0.5	1.2	1.2
Mean Expenditures						
Non-Electricity			12	0.9	2.2	1.0
Non-Natural Gas			13	1.0	2.5	1.9
Non-Gasoline			10	0.8	1.7	1.9
Marginal (weighted by $\epsilon_{I,0}$) Expenditures						
Non-Electricity			16	1.1	3.4	1.6
Non-Natural Gas			16	1.1	3.4	1.7
Non-Gasoline			7	0.5	1.3	1.1

Sources: Emissions/\$ from EIO-LCA02; U.S. household expenditure shares (w_o) from U.S. Consumer Expenditure Survey, 2004 in (2002\$); $\epsilon_{I,0}$ from Taylor and Houthakker, 2010.

3.7.5 Background on the Consumer Expenditure Survey

The Consumer Expenditure Survey (CES) is an annual compilation of data from two separate nationally representative samples of households: a bi-weekly Diary survey and a quarterly Interview survey. The Diary survey is conducted as two consecutive 1-week surveys, and collects expenditure data on smaller food, personal care, and household expenses. The Interview Survey is conducted over five consecutive quarters, and collects data on expenditures on recurring expenses such as rent and utilities, and larger purchases, such as property, automobiles, durable

goods, and medical expenses. The Interview Survey also collects before- and after-tax income data, however these are less reliable due to recall errors, privacy concerns, etc.

Respondents to the CES are known to systematically underreport health, clothing, and other expenditures compared with personal consumption expenditures collected as part of GDP figures due to issues such as recall errors and sampling bias (Weber, 2008). The public CES data are divided into 74 expenditure categories, and we use the more detailed 674-sector pre-publication tables with detailed air travel expenditures, which has to be allocated into the 428 EIO-LCA sectors, and may suffer sector misallocation error. The 428-sector CES data are used to calculate lifecycle household carbon emissions, termed the household carbon footprint (HCF) and measured in ton CO₂e using EIO-LCA. The ratio of lifecycle emissions per dollar spent in a given expenditure category is also listed.

Chapter 4: A Regional Assessment of Direct and Indirect Rebound Effects in the U.S. for Electric End-Uses^{iv}

Abstract

Governments and regional entities in the United States are starting to rely on energy efficiency improvements to meet diverse and competing goals such as reducing CO₂e emissions, reducing air pollution, minimizing investments in new power plants, and creating jobs. However, energy efficiency interventions that have economic savings are likely to lead to a response from consumers and a reallocation of their budget expenses, known as rebound effects. In this chapter, we assess the environmental consequences of such effects in terms of CO₂e, SO₂ and NO_x emissions for energy efficiency interventions in electric end-uses. We model the indirect rebound given a direct rebound parameter from literature for an energy efficiency investment by the average household in each of the 50 states. We find that CO₂e direct and indirect rebound effects vary between 6-40%, when including scope 1, 2, and 3 emissions, and between 4-30% when including only scope 1 and 2 emissions. However, states with a higher percentage rebound effect also often have low grid emissions factors (GEFs), so that the associated rebound in emissions is small. We discuss the limitations of using only scope 1 emissions for policy decisions and how estimates using full supply chain emissions can be used to support decisions on climate change mitigation at different geographic scales.

4.1 Motivation

In the United States, governments, states and local entities, are starting to rely on energy efficiency investments to meet diverse and sometimes competing goals such as reducing CO₂ emissions to mitigate climate change, reducing air pollution to improve local air quality,

^{iv} A version of this chapter will be submitted to *Environmental Science and Technology*. Authors: Thomas, B.A., Hausfather, Z., Azevedo, I. L.

minimizing the investments needed for new electric power plants, and creating jobs. Researchers have found that in many cases, electric utility energy efficiency programs have resulted in annual energy savings at an average cost well below the cost of generation from new power plants, which makes energy efficiency one of the most cost-effective means to achieve emissions reductions (Aufhammer et al., 2008; Parfomak and Lave, 1996). However, studies of the energy efficiency potential typically assume that consumers do not re-spend energy cost savings and have the same energy service demand before and after an energy efficiency investment (McKinsey and Co, 2009; Azevedo, 2009). This assumption has been questioned by energy economics and industrial ecology research on side effects of energy efficiency, known as the rebound effect.

The energy efficiency rebound effect can be defined as the difference between expected or potential energy or emissions savings (PES) from an energy efficiency measure in an engineering assessment which assumes no re-spending of energy cost savings, and the actual energy or emissions savings (AES) with an efficiency investment after accounting for re-spending behavior, expressed as a percentage, $R = 1 - AES/PES$. The rebound effect in percent could be measured with respect to primary energy, or pollutant emissions (CO₂e, NO_x, SO₂ for example) or another environmental impact.

Energy efficiency rebound effects describe two main consumer responses to the implementation of energy efficiency measures: re-spending energy cost-savings on increased usage of the efficient technology due to its lower operating costs, called the *direct rebound*, and re-spending energy cost savings on other goods which incur additional supply-chain energy and emissions for their production and use, called the *indirect rebound*. For example, households may use efficient CFL lightbulbs more often than incandescent lamps (direct rebound), or re-spend the electricity cost savings on a new TV or for a vacation (indirect rebound). In this chapter, we

compare and integrate methods used by industrial ecologists and economics, to provide a novel way to estimate the direct and indirect rebound effect for the average household in each of the 50 U.S. states. While the industrial and commercial sector may exhibit similar behaviors and rebound effects (Safarzyńska, 2012; Greening et al., 2000; Binswanger, 2001), in this chapter we restrict our focus to residential rebound effects. Also outside the scope of this chapter is a third effect at a macro level, in which widespread investments in energy efficiency may lead to a decrease in the market price of energy, which triggers macroeconomic changes in economic structure and energy demand (Brookes, 1990, 2000; Saunders, 2000; Turner, 2009; Wei, 2010); this is called the *economy-wide rebound effect*.

Energy economists tend to measure the rebound effect as the percentage change in energy service demand, S , with respect to a percentage change in efficiency, ϵ , known as an efficiency elasticity. An efficiency elasticity is equivalent to the negative of the price elasticity of energy services, P_S , under the assumption of exogenous energy prices, P_E (Khazzoom, 1980; Berkhout et al., 2000; Sorrell and Dimitropoulos, 2008; Wirl, 1997). Research on the direct rebound effect tends to use econometric studies of household energy consumption and elasticities and find that this effect varies between 5-20%, depending on household income (Small and van Dender, 2005, 2007; Frondel, 2008; Gillingham, 2011), region, and energy end-use (Greening et al., 2000; Davis, 2012). Direct rebound effects in developing countries such as China, India, and Mexico have been found to be considerably greater, and in some regions over 100%, depending on the end-use (Roy, 2000; Davis, 2012; Wang et al., 2012).

Energy economists also jointly estimate direct and indirect rebound effects through econometric studies of households' price elasticity of energy and the cross-price elasticities of energy demand, which are defined as the percent change in demand for non-energy goods, O ,

with respect to a percent change in the price of energy. These cross-price elasticities are coupled with estimates of the emissions from the direct combustion of fuels, known as scope 1 emissions, or those from purchased electricity, or scope 2, emissions to estimate the indirect rebound effect (Wang et al., 2012; Brannlund et al, 2007; Mizobuchi, 2008; Kratena and Wuger, 2010).

Brannlund et al. (2007) find that the direct and indirect rebound effects for Swedish households are 121%, and that an investment in efficiency *increases* CO₂e emissions, called “backfire” (Khazzoom, 1980; Saunders, 2000). Using the same methodology on Japanese expenditure data, Mizobuchi (2008) finds that including capital costs decreases the direct and indirect rebound effect to 27%. However, the energy economics approach of using energy price elasticities tends to overestimate the direct rebound effect because investments in energy efficiency are correlated with rising energy prices (Small and van Dender, 2005; Hunt and Ryan, 2011; Hanly et al., 2002; Henly et al., 1988).

In addition, these economic studies have not accounted for evidence from the industrial ecology literature that suggests that up to half of all of the household’s total carbon emissions, or “carbon footprint” (HCF) can be attributed to the upstream supply chain, known as scope 3 emissions, of non-energy goods and services, as demonstrated with household expenditure data in the U.K. (Druckman and Jackson, 2009), the U.S. (Weber and Matthews, 2008), in different U.S. cities (Jones and Kammen, 2011), and in a multi-regional trade-linked analysis of 73 nations (Hertwich and Peters, 2009). Direct rebound effects from operating cost savings are increasingly being incorporated parametrically in life-cycle assessment (LCA) studies to quantify the net impacts of diverse climate mitigation actions other than efficiency such as fuel switching (Mazzi and Dowlatabadi, 2007), or comparing the net benefits of smart growth vs. vehicle hybridization (Stone et al., 2009). For the indirect rebound, industrial ecology studies use environmentally

extended input-output (EEIO), process-based, or hybrid life cycle assessments, which provide unique tools to estimate the indirect rebound effect from energy efficiency and other sustainable consumption measures (Hertwich, 2005a). EEIO models are especially useful to highlight the risk tradeoffs between reductions in environmental indicator and increasing impacts in another (Hertwich, 2005b). Hertwich (2005b) argues that the indirect rebound, in particular, depends on the relative supply chain emissions of various goods and services.

A common simplifying assumption in prior industrial ecology studies of the indirect rebound has been that households spend energy cost savings in proportion to current spending (Lenzen and Day, 2002) from a measure such as teleworking (Kitou and Horvath, 2003), switching from car to train or bus travel (Takase et al., 2005), or vehicle lifetime extension (Kagawa et al., 2011). A growing number of studies distinguish between proportional (average) spending patterns and marginal spending patterns using income elasticities to assess the indirect rebound effects from a variety of efficiency and conservation measures, and find it to vary between 15-50%, depending on the measure taken (Alfredsson, 2004; Girod and de Haan, 2010; Thiesen et al., 2008; Druckman et al., 2011; Murray, 2011; Chitnis et al., 2012). However, these studies do not include the direct rebound effect, which limits comparison to economic studies. Other studies have included direct rebound estimates to explore the relationships between the direct and indirect rebound effects, incorporating the effects of savings (Freire-Gonzalez, 2011), break-even capital costs (Nassen and Holmberg, 2009), and cross-price elasticities (Chapter 3) and find the indirect rebound effects in the 5-25% range.

This chapter is motivated by results from the EEIO and cross-price elasticity-based model of direct and indirect rebound effects in Chapter 3 that indicate that the indirect rebound is highly sensitive to the electric grid emissions factor (GEF, measured in kg CO₂e/kWh), which is

naturally dependent on the electrical grid mix. We have two main goals for this chapter. First, we examine the influence of electric emissions factors and other factors on the extent of the direct and indirect rebound effect for energy efficiency investments by typical households in the 50 U.S. states using 2004 Consumer Expenditure Survey (CES) (BLS, 2004) and an EEIO model, the purchaser price, 2002 economic input-output lifecycle assessment model (EIO-LCA) (Hendrickson et al., 2006; www.eiolca.net). Second, we compare state-level direct and indirect rebound estimates using only scope 1 emissions for natural gas and gasoline and scope 1 and 2 emissions for electricity with indirect rebound estimates using scope 1, 2, and 3 emissions for all household expenditures, to highlight the importance of the EEIO approach to estimating indirect rebound effects.

This chapter is organized as follows: Section 4.2 describes an overview of the direct and indirect model, Section 4.3 describes key data sources, Section 4.4 provides our estimates of direct and indirect rebound effects by state, and Section 4.5 concludes with a discussion of the application of rebound estimates using scope 1 and scopes 1-3 supply chain emissions for efficiency policy analysis. Consideration of the rebound effect is especially important for the 20 states which have established Energy Efficiency Resource Standards (EERS) and 7 states with voluntary energy efficiency goals (DSIRE, 2012), as well as for the 141 cities and counties that have developed or are in the process of developing Climate Action Plans (ICLEI, 2012), in order for utilities and policymakers to know what level of effort and what costs will be imposed to meet these goals after accounting for consumer behavior.

4.2 Direct and Indirect Rebound Model

We use the method developed in Chapter 3 which derived cross-price elasticities from microeconomics to model the indirect rebound effect (R_{I-CS}) in percentage terms, given an

estimate of the direct rebound effect, and historical national U.S. income elasticity estimates as shown in Eq. 4-1. For tractability, this model assumes that each fuel used by the household provides a single energy service. We use these cross price elasticities to predict the marginal spending patterns of households under a change in the price of energy services from efficiency, using data from the 2004 U.S. Consumer Expenditure Survey (CES) (BLS, 2004).

We also coupled these cross-price elasticities with supply chain (including scopes 1, 2, and 3) primary energy, CO₂e, NO_x, and SO₂ emissions from the economic input-output lifecycle assessment (EIO-LCA) purchaser price model for the U.S. in the year 2002, the latest year available (Hendrickson et al., 2006; www.eiolca.net). EIO-LCA assumes fixed prices in 2002\$ throughout the U.S. economy, linear production functions for all commodities and sectors, and constant returns to scale. While restrictive, these assumptions are sufficient for our goal to study the marginal changes in consumption from re-spending energy cost savings from an energy efficiency investment, and linearity adds the benefit of easy computation. For simplicity, the emissions impacts of savings are excluded in our model. We used the 2004 Consumer Expenditure Survey (CES) with the 2002 EIO-LCA model due to improved data processing procedures implemented in 2004. These expenditures, collected at 2004 prices, were converted to 2002\$ by the urban, all-goods Consumer Price Index (CPI) for the Northeast, Midwest, South and West Census regions (BLS, 2002) for use in the EIO-LCA model.

The model estimates indirect rebound effects for typical households for several geographic areas, such as a state, from re-spending on goods produced in the U.S. given its 2002 economic structure and commodity prices. Thus, it provides a snapshot of the indirect rebound effect, given an assumption of the direct rebound, and will likely change as prices and spending patterns change. For comparison, we also compute indirect rebound effects using proportional spending

(R_{I_PRP}) patterns, which assumes that the income elasticity for all goods, $\eta_{o,I}$, is equal to 1.0 and that the cross-price elasticity for good O with respect to the price of energy services, P_s , is equal to negative of the other-goods budget share, w_o , for comparison, shown in Eq. 4-2 (see Chapter 3).

$$R_D + R_{I-CS}[\%] = -\eta_{S,P_S} + (\eta_{S,P_S} + w_S \eta_{S,I}) \frac{\sum_{O=1;\neq S}^n E_O w_O}{E_S \sum_{O=1;\neq S}^n w_O} + \frac{\sum_{O=1;\neq S}^n \eta_{O,I} E_O w_O}{E_S} \quad 4-1$$

$$R_D + R_{I_PRP}[\%] = -\eta_{S,P_S} + \frac{\sum_{O=1;O\neq S}^n E_O w_O (1 + \eta_{S,P_S})}{E_S (1 - w_S)} \quad 4-2$$

Where

η_{S,P_S} = own-price elasticity for an electricity service, s , a measure of the direct rebound,

$\eta_{S,I}$ = income elasticity for the electricity end-use s ,

$\eta_{o,I}$ = income elasticity for good o ,

w_S = share of household budget for electricity end-use s ,

w_o = share of household budget for good o ,

E_S = direct emissions intensity per dollar of expenditure on an electricity end-use [e.g. kgCO₂e/\$, gNO_x/\$, gSO₂/\$], which is equal to grid emissions factor, GEF [e.g. kg CO₂e/kWh] divided by electricity price, P_E [\$/kWh], and

E_o = direct or embodied emission emissions per dollar of expenditure on a non-electricity good from the 2002 EIO-LCA purchaser price model.

In the second term in Eq. 4-1, $(\sum_{o=1,o\neq S}^n E_o w_o) / (\sum_o w_o)$, emissions are weighted by the household's budget shares from annual expenditures to represent emissions from the average pattern of household spending. In the third term in Eq. 4-1, emissions are weighted by the product of budget shares and income elasticities, which measures marginal spending shares. In Chapter 3, we compared the different approaches to calculating the indirect rebound effect and found that modeling the indirect rebound effect from electricity efficiency using Eq. 4-2 provided estimates at the low end of the range of estimates obtained with Eq. 4-1 using different sets of income elasticities. We provide state-level comparisons of the proportional spending and cross-

price elasticity approaches to estimating indirect rebound in Table 4-3, Table 4-4, and Table 4-5 of the SI.

As in Weber and Matthews (2008), we obtain scope 1 (combustion) emissions for natural gas and gasoline by dividing 2004 CES fuel expenditures by 2004 prices and multiplying by CO₂ conversion factors for each fuel. When calculating the indirect rebound effect using scope 1 emissions for fuels, only these combustion emissions are included in emissions estimates for other goods, E_o . For our calculations of the indirect rebound effect including scope 1, 2 and 3 supply chain emissions, we sum scope 1 emissions for gasoline and natural gas with estimates of E_o for all other sectors from the 2002 EIO-LCA purchaser price model.

The scope 2 emissions for electricity are simply $E_s = \text{GEF}/P_E$. When we measure the indirect rebound effect using scope 1, 2, and 3 emissions, we assume that an additional 10% of CO₂e and SO₂ emissions can be attributed to supply chain emissions, which is the order of magnitude of upstream energy and emissions impacts for fossil fuel electricity production (Jaramillo et al., 2007). For NO_x, we use a 50% calibration factor to scale from 2005 NO_x direct GEFs to the 2002 supply-chain GEFs used in EIO-LCA from 2002, since NO_x cap-and-trade programs had begun to expand from the Northeast to other states during 2002-2005 (EPA, 2012). In addition, we must calibrate E_s by the ratio of population-weighted state average residential electricity prices in 2004 (in 2002\$) of \$0.085/kWh, to the 2002 all-sector average electricity price of \$0.072.kWh used in EIO-LCA to calculate the environmental emissions vector (see the Section 4.7.1 of the Supporting Information (SI) for details for the model).

The resulting net emissions once direct and indirect rebound effects for CO₂e are taken into account can be obtained by multiplying Eq. 4-1 by $E_s I w_s \tau$, the amount of energy or emissions reduced with the efficiency investment, where I is the household income (total expenditures), and

τ is the percentage reduction in energy consumption with an efficiency investment. Eq. 4-1 implies that naturally, the higher the direct rebound in percent, the lower the indirect rebound in percent and vice versa (since $\eta_{S,PS} < 0$ and $\eta_{S,I} > 0$). Eq. 4-1 also implies that the indirect rebound in CO₂e emissions for electricity efficiency increases as the GEF decreases, and we quantify this effect using average household expenditure and household carbon footprint data.

4.3 Data

For this study, we disaggregate rebound effects by state, by assuming the households in each state spend in similar patterns as other households in their Census region, and augmenting the CES data with state-level EIA data on household electricity and gasoline expenditures. State-level rebound results are especially relevant since current climate mitigation and energy efficiency policies, such as EERS policies, are being developed at the state level. Finer levels of disaggregation may be possible but are not considered in this analysis. Our data sources are available at varying levels of disaggregation, as summarized in Table 4-1. The Consumer Expenditure Survey (CES), collected by the Bureau of Labor Statistics (BLS), is designed to be a statistically representative sample of households in selected metropolitan areas and in the four Census region levels; these data are not statistically representative at the state level. Electricity prices vary considerably by utility service areas within and among states. Electricity emissions and primary energy consumption data, collected by the Energy Information Administration (EIA) of the Department of Energy and the U.S. Environmental Protection Agency (EPA) are available at the generator (boiler or plant) level, but pose aggregation challenges, which will be discussed further (EPA, 2007).

Eq. 4-1 models the direct and indirect rebound effect in terms of eight parameters. These include $\eta_{S,PS}$, the price elasticity of energy services, w_s and w_o , the budget share for the electricity

end-use and non-electricity goods, $\eta_{S,I}$ and $\eta_{O,I}$, the income elasticity for the electricity end-use and non-electricity goods, E_o , the direct (scope 1 for natural gas and gasoline, and scope 2 for electricity) or supply chain (scope 1, 2, and 3) energy- or emissions per dollar of expenditure on non-electricity goods, GEF, the grid emissions factor, and P_E , the price of electricity. The following sub-sections highlight data sources for each of these parameters, the statistically representative scale at which the data is available, as well as how we adapted the data for a state-level analysis.

Table 4-1: Summary of data sources and geographical detail

Variable	Symbol	Time Frame	Geographical Detail	Source
Direct rebound (price elasticity for electric end-use services)	η_{S,P_S}	1981-1983	Florida, proxy for national average response	Dubin et al., 1986
Electricity budget share	$w_{s,elec}$	2004	State-level	EIA, 2007; ACS, 2009
Gasoline budget share	$w_{o,gasol}$	2004	State-level	EIA, 2007; ACS 2009
Residential electricity price	P_E	2004 (in 2002\$)	State-level	EIA, 2007; ACS, 2009
Other goods budget share	w_o	2004	4 Census region levels	CES, 2004
Income elasticities	$\eta_{S,I}, \eta_{O,I}$	1996-1999	National, linearly adjusted to meet budget constraint given budget shares	Taylor and Houthakker, 2010
Grid emissions factor	GEF	2005	26 eGRID levels and 8 NERC levels, with national coverage and boundaries overlapping states	EPA, 2007
Embodied emissions per dollar of other goods	E_o	2004	National	EIO-LCA, 2002

4.3.1 Price Elasticity of Energy Services

Following Chapter 3, we assume that the direct rebound effect is 2-13%, using results from a cross-sectional econometric study of Florida households (Dubin et al., 1986). Electricity end-use direct rebound estimates using metered appliance data and appliance efficiency information are rare, but the gold standard of direct rebound estimates. However, in principle, any direct rebound estimate could be used in the model. Comprehensive direct rebound results in terms of price elasticities for electric appliance services for other regions of the U.S. are not available to our knowledge, although there is a large literature on electricity price elasticities (Bohi and Zimmerman, 1984; Espey and Espey, 2004) that do not take appliance efficiency into account and serve as upper bounds of the direct rebound effect (Hanly et al., 2002; Henly et al., 1988).

4.3.2 Budget Shares and Prices for Electricity and Gasoline

The regional CES tables provide statistically representative, but highly aggregated, estimates of household budget shares for all goods in the four Census regions which mask much of the variation in electricity expenditures by state. We instead use EIA's 2004 data on state-level annual electricity sales (in MWh) and average residential retail electricity price (in \$/kWh) to estimate total electricity expenditures (\$/yr) per state (EIA, 2007). Total electricity expenditures are divided by the 2004 American Community Survey (ACS) state-level household population and divided by 2004 ACS state median household incomes (\$/yr), to obtain average electricity budget shares (Census Bureau, 2009). We use a similar procedure on EIA state-level gasoline expenditures data to obtain average household gasoline budget shares by state. These estimates preserve the considerable variation in state electricity expenditures using statistically representative datasets and provide a better estimate of electricity expenditures than the consumer

expenditure data. This is important because indirect rebound estimates are sensitive to gasoline budget share (see Chapter 3).

4.3.3 Budget Shares for Other Goods

Household spending patterns and budget shares for non-electricity goods are assumed to be similar to that of the average household in the Census region in which the state is located using CES data (BLS, 2004). We also linearly adjust other goods budget shares to sum to unity given the state-level average household electricity and gasoline budget shares obtained from EIA (EIA, 2007).

4.3.4 Income Elasticities

Income elasticities are national averages from Houthakker and Taylor (2010)'s studies of past U.S. Consumer Expenditure Surveys, shown in Table 4-2 in the SI. The product of income elasticities and budget shares provide an indication of the marginal expenditure for the typical household. Table 4-2 shows that the average U.S. household spends between 20-36% of the next dollar on transportation and 51-56% on miscellaneous expenses, such as apparel, entertainment, and services, with the range depending on functional form of income elasticities. Households re-spending electricity cost savings on increased driving and other services requiring gasoline is the main behavioral driver of the indirect rebound results in this chapter. We calculate indirect rebound effects using both sets of elasticities and report the mean of the two estimates in the chapter and the range of rebound results in the SI.

4.3.5 Grid Emissions Factors

Weber et al. (2010) extensively analyzed the limitations of knowledge about electricity emissions for LCA models and argued that calculating GEFs based on the location of generators within state boundaries ignores inter-state electricity flows and the topology of the electric grid.

We follow Weber et al. (2010)'s guidelines and calculate rebound effects using GEFs from 2005, due to lack of CO₂e (vs. CO₂) emissions data in 2004, from two different grid delineations, based on the ten North American Reliability Corporation (NERC) regions or 26 EPA emissions and generation resource integrated database (eGRID) regions, given the uncertainty in attributing the source of an electron consumed within a state (See SI for region boundaries). We will mainly discuss eGRID results in this chapter, and present NERC region results in the SI. When a state's boundaries contained more than one NERC or eGRID region, we assign the state a GEF weighted by the population contained in each region using boundary information and 2004 zip-code level American Community Survey (ACS) population estimates. Transmission loss data from 2005 at a state level via EIA 2007 is used to further refine household-level GEF estimates. A consumption-based GEF accounting scheme is also valid and produces different results (Marriott and Matthews, 2005) but we abstract from these differences in this analysis.

Marginal GEFs for CO₂e are also important for assessing the carbon emissions effects of energy efficiency interventions than average GEFs because energy efficiency displaces a different set of generation technologies than base-load demand (Siler-Evans et al., 2012). Siler-Evans et al. (2012) measure marginal GEFs for CO₂e, NO_x, and SO₂ emissions for NERC regions and show that average GEFs can misestimate emissions impacts of efficiency, but to a lesser extent for CO₂e emissions, the focus of the discussion in this chapter. In our results, we abstract from the differences between marginal and average GEFs in order to ensure consistent treatment of embodied emissions from electricity services and other goods, which are calculated with an EEIO model using a national average GEF; a national marginal GEF has limited physical meaning.

4.3.6 Emissions Per Dollar of Other Goods Expenditure

Emissions per dollar of expenditure on non-electricity goods come from the 2002 EIO-LCA model, following Weber and Matthews (2008), in which combustion emissions for gasoline and natural gas use were included using 2004 U.S. average retail prices (in 2002\$) by state for these fuels and CO₂ emissions conversion factors (see SI). We assume that goods are produced nationally and transported to the various regions of the U.S., so that national supply chain emissions per dollar of expenditure are representative of the household carbon footprint in the different regions. In assuming nationally produced goods, we are likely to be misestimating the supply chain emissions for imported goods, which contributed up to 30% of total household carbon footprint in 2004 (Weber and Matthews, 2008). However, we are most interested in relative differences in indirect rebound effects across states, and these are most strongly influenced by the average GEF as seen in Chapter 3.

4.4 Direct and Indirect Rebound Results

Assuming that Dubin et al. (1986)'s mean estimate of a direct rebound effect in electric air conditioning of 8% ($\pm 6\%$) are representative of most households in U.S. states, we calculate the indirect rebound effect in percent and CO₂e emissions from an electrical efficiency investment made by the average household in each of the 50 U.S. states and the District of Columbia. We use Eq. 4-1 to calculate CO₂e indirect rebound effects in percent with scope 1 emissions for natural gas and gasoline and scope 2 emissions for electricity, and scope 1, 2, and 3 emissions as shown in Table 4-3 of the SI. We will present visualizations of rebound results with scopes 1, 2 and 3 emissions in the chapter, although we will provide a comparison with rebound effects measured with scope 1-2 emissions. State-level indirect rebound effects in NO_x and SO₂

emissions from residential electricity efficiency investments are discussed here, and the main results are presented in Table 4-4 and Table 4-5, respectively, in the SI.

4.4.1 Consequences of Emissions Rebound Depend on Abatement Objective

By comparing the expected emissions savings ignoring re-spending with the actual savings once accounting for re-spending behavior, we calculate indirect rebound effects in percent and in CO₂e emissions from efficiency investments made to achieve the following four objectives, as described in Chapter 3:

- (a) reducing 1 ton of embodied CO₂e emissions from electricity (before re-spending), which is equivalent to the percent rebound,
- (b) reducing 20% of the household's annual electricity bill,
- (c) reducing 2 MWh/yr of annual electricity consumption, and
- (d) reducing \$200 from the household's annual electricity bill.

These four scenarios can be visualized in Figure 4-1, which shows that direct and indirect rebound in percent varies between 12%(±6%) to 31%(±8%), with mean results displayed, when using scope 1, 2, and 3 emissions. Most of the uncertainty in our rebound estimates is due to uncertainty in the direct rebound parameter (±6%), and a smaller portion is due to uncertainty in income elasticities. If using scope 1 and 2 emissions from re-spending electricity cost savings on natural gas and gasoline, the direct and indirect rebound effect would decrease to 10%(±6%) to 19%(±8%). In maps (b-d), Figure 4-1 also shows the direct and indirect rebound in CO₂e emissions (vs. percent) for efficiency investments made by the average household in the 50 states to meet objectives the latter three objectives. Each of these four objectives corresponds to a different relative (percentage) improvement in electrical end-use efficiency across states, except for scenario (b). The percentage rebound is the same in for all four goals since Eq. 4-1 does not depend on the percentage improvement in end-use efficiency. However, the direct and indirect

rebound effect in CO₂e emissions, obtained by multiplying the percent rebound by the emissions abatement objective, does depend on technical efficiency improvement.

There are three main lessons to draw from these maps. First, map (a) in Figure 4-1 shows that households in states with low grid emissions factors and high electricity prices, such as the Western and New England states, have higher indirect rebound effects in percent compared to the average U.S. household. The goods purchased by these households are likely to be produced in other parts of the U.S. or world with higher GEFs than their home state, so the emissions from this re-spending are relatively high compared to the emissions saved with electrical end-use efficiency. Conversely, households in states in the Midwest or South with cheap, carbon-intensive electricity have lower indirect rebounds in percent.

For example, reducing energy expenditures by 20% in Texas is equivalent to reducing annual household embodied CO₂e emissions by 2.5 tons and would result instead in a reduction of 2.1 tons CO₂e after accounting for direct and indirect rebound effects of 18%. In contrast, an energy efficiency policy in New York aiming at reducing energy efficiency expenditures by 20% would have only a reduction of 0.54 tonCO₂e (instead of the anticipated 0.70 tonCO₂e if direct and indirect rebound effects of 26% are not considered).

This leads to the second point to draw from maps (a-d) in Figure 4-1, that although Western or New England households investing in electrical end-use efficiency may have higher percent rebound effects, the consequences in terms of CO₂e emissions and resulting climate impacts are relatively low. However, at levels of 25-30+%, however, these rebound effects may alter the cost-effectiveness of energy efficiency relative to other CO₂e mitigation options in these states, although this is a topic for further investigation.

Third, comparisons of energy efficiency savings and rebound effects across states will depend on the framing of the energy efficiency goal. For example, an efficiency measure which reduces annual electricity expenditures by 20%, map (b), results in the highest direct and indirect rebounds in CO₂e emissions in states with greater electricity needs and higher electricity budget shares. When the abatement goal is defined in terms of MWh, such as in map (c), households in Midwest states with high GEFs experience the highest direct and indirect rebound in CO₂e emissions. Midwest and Southern states have even higher direct and indirect rebounds in CO₂e emissions when the abatement goal is framed in terms of annual electricity bill savings, map (d), since these states have both high GEFs and low electricity prices.

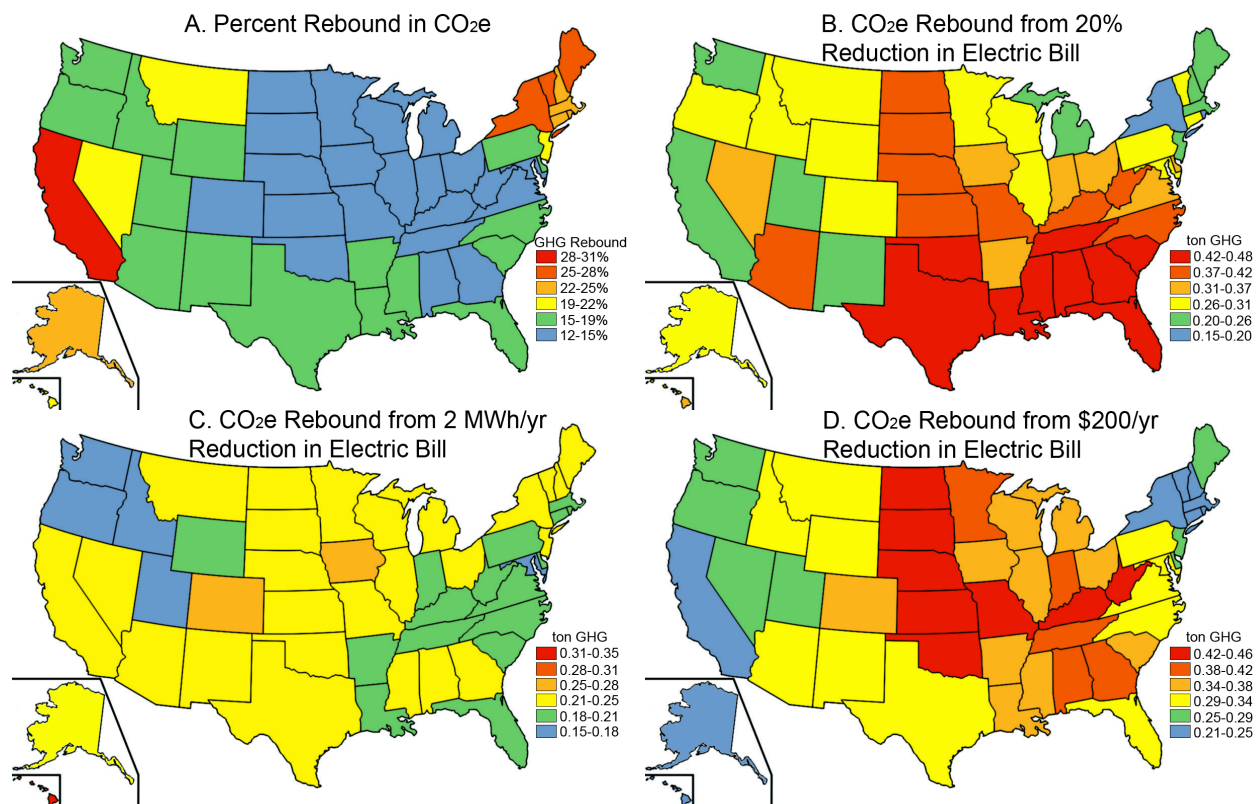

Figure 4-1a-d: Direct and indirect rebound effects in CO₂e emissions by state. Results are shown in (a) relative or percentage terms, (b) for a 20% reduction in annual household electricity bills, (c) for a 2 MWh/yr reduction in electricity consumption, and (d) for a \$200 reduction in annual household electricity bills, and are based on eGRID GEFs.

4.4.2 Rebound Effects are Small Relative to Household Carbon Footprints

Figure 4-2 provides a detailed comparison of the typical household in two large states, California (CA) and Minnesota (MN), compared to the U.S. as a whole, using scenarios normalized to reduce 2 ton CO₂e in the average U.S. household's carbon footprint, before accounting for rebound effects, and framed in terms of reductions in electricity bills (in percent or dollars) or in annual electricity (in MWh) consumed. The typical Minnesota household experiences a direct and indirect rebound of 13%(±6%) including scope 1, 2, and 3 emissions and 10%(±6%) including just scope 1 emissions from re-spending electricity cost savings on natural gas heating or driving gasoline-powered vehicles. In contrast, California households experience a direct and indirect rebound effect of 31%(±8%) including scope 1, 2, and 3 emissions and 19%(±8%) including just scope 1 emissions. However the consequences of these higher percent rebound effects are low, because of California's lower than average household carbon footprint (HCF). As Figure 4-2 shows, the direct and indirect rebound effects are small for the average household in California, Minnesota, and in the U.S. as a whole. However, these various electricity efficiency scenarios also lead to very small changes (<2%) of the household's CF, since electricity constitutes only 9-36% of HCF across states.

Abatement goals framed in terms of percentage reductions in household electricity consumption, dollar reductions in household electricity bills, or per household reductions in MWhs of electricity consumption will not lead to significant net savings in California's HCF, although larger net CO₂e savings can be achieved in Minnesota and the U.S. as a whole with such goals. A goal such as reducing 2 tons of embodied CO₂e emissions from electricity per household would be highly aggressive in California, requiring almost a two-thirds reduction in household electricity consumption, while it would be relatively modest to achieve in Minnesota (17%

reduction) or the U.S. (21% reduction) as a whole. For households in California, reducing 2 ton embodied CO₂e or more would likely require measures in transportation efficiency and changes in consumption patterns as well, which the Jones and Kammen (2011) also find in a city-based household carbon footprint and efficiency potential analysis. Figure 4-2 also highlights that efficiency investments yielding the same percentage reduction in household energy bills in California and Minnesota will result in significantly different CO₂e emissions reductions, because of differences in GEF, electricity demand, electricity prices and resulting indirect rebound effects.

The results in Figure 4-2 use eGRID-region CO₂e GEFs, which contains the greatest state-level variation in emissions factor and indirect rebound effects. However, NERC region GEFs may be important for assessment of rebound effects for California, in particular, because it imports a large fraction of its electricity (LBL, 2009) and the CAMX eGRID region has a much lower GEF than the broader WECC NERC region. As seen in Table 4-3 in the SI, rebound effects using eGRID GEFs and NERC CO₂e GEFs differ about only about 1-2% for most states, except in California where the CO₂e direct and indirect rebound (in percent) lies somewhere between 23-39% using eGRID region GEFs and 17-31% using NERC region GEFs, and in Colorado, with rebound effects of 7-19% using eGRID region GEFs and 12-25% using NERC region GEFs. However, Colorado imports very little of its electricity (LBL, 2009). Table 4-4 and Table 4-5 suggest that the difference between eGRID and NERC regions in calculating indirect rebound effects appears to be more important for NO_x and SO₂, as these emissions are more variable across states.

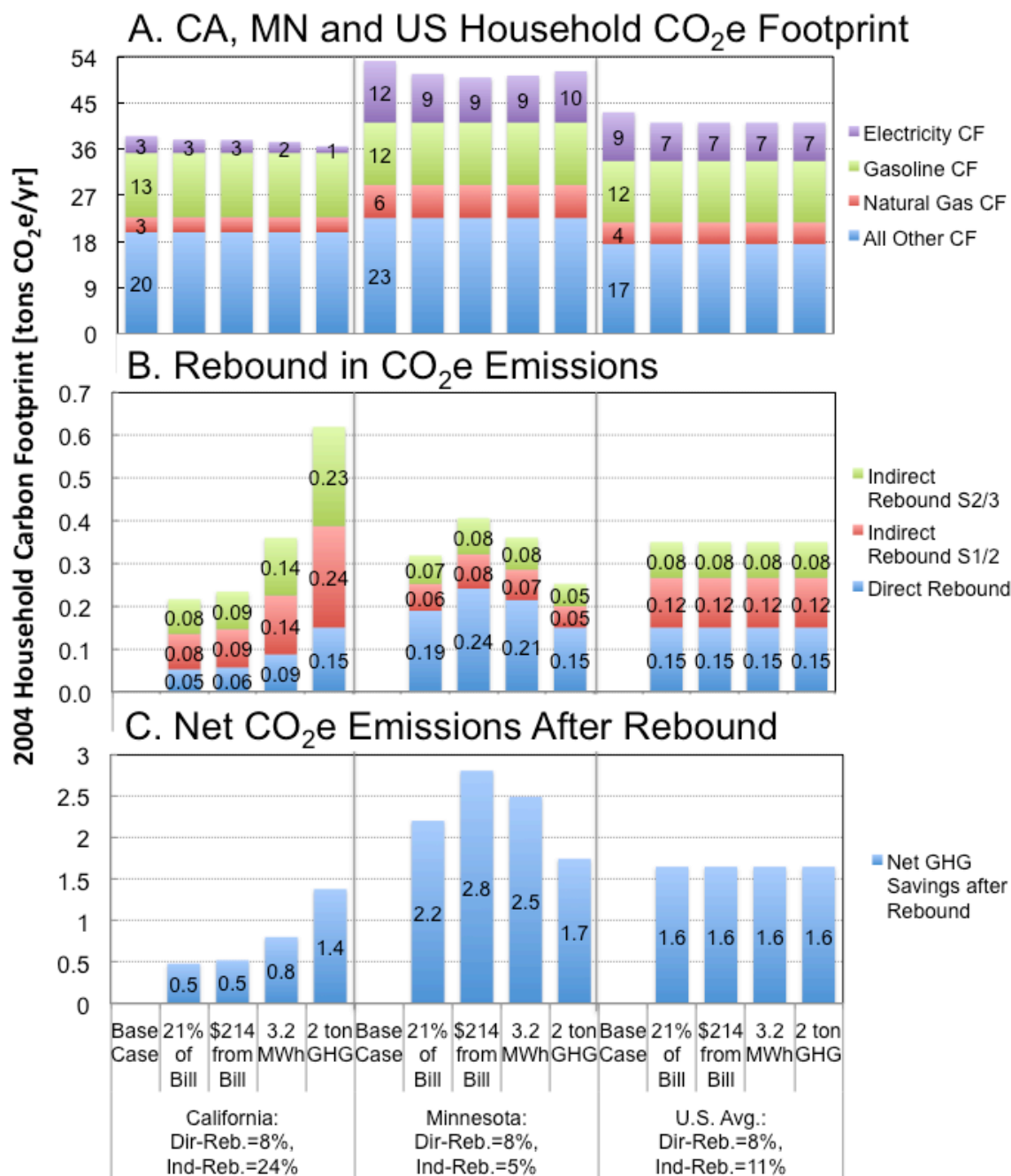

Figure 4-2a-c. (A) Household carbon footprints, (B) direct and indirect rebound effects, and (C) net CO₂e savings for 5 electricity service efficiency scenarios for the average household in California, Minnesota, and the U.S.

Notes: The 5 scenarios for expected supply chain CO₂e savings with electricity efficiency before accounting for rebound effects include (1) “Base-case,” the emissions prior to energy efficiency measures, (2) “21% of Bill,” the emissions under a 21% lower electricity bill, (3) “\$214 from Bill,” the emissions with \$214 lower annual electricity bills, (4) “3.2 MWh” emissions with 3.2 MWh lower annual electricity consumption, and (5) “2 ton GHG” emissions with reduction of 2 ton of CO₂e from the household’s carbon footprint from electricity.

4.5 Application of Rebound Results in Policy Analysis

There are considerable data uncertainties to be overcome to empirically measure the direct and indirect rebound effect, given that they depend on income and energy service price elasticities, income, household spending allocation on different goods and services, relative prices, and other factors, many of which are likely to vary by region. For example, with regional prices and household expenditure data for fuels, regional income elasticities could be estimated to more precisely measure the regional variation in indirect rebound effects, which we are pursuing in future work. The ideal data for measuring the direct and indirect rebound effects would require a survey of the energy and other expenditures for a panel of households over time, including both a control group and households making efficiency investments. The results presented here, based on simulated electrical efficiency investments, national income elasticities based on historical data, and a direct rebound parameter, provide a first order estimate of the magnitude of the indirect rebound effect and how it varies by state largely due to variation in the grid emissions factor and electricity prices.

Based on our simulations, we predict that the direct and indirect rebound effects from a hypothetical electrical efficiency investment by households will be modest to moderate, ranging from a low as 6% for a state with a high GEF and low electricity prices like Minnesota, to as high as 40% for a state with a low GEF and high electricity prices like California, including scope 1, 2, and 3 emissions. If using just scope 2 emissions for electricity savings from efficiency and scope 1 emissions from natural gas or gasoline purchases, the direct and indirect rebound would be measured as 4 to 30% across states. However, as it is a re-spending effect, the indirect rebound will depend on the relative prices of non-energy and energy goods, which are especially volatile. Higher indirect rebound effects in percent occur mainly in areas of the U.S. and world with low

GEFs, where the consequences of rebound effects in CO₂e emissions and climate impacts are relatively low. At current levels, residential rebound effects in the U.S. are only important for policy decision-making if they lead to a switch in investment decisions for energy efficiency versus other carbon abatement options.

As more data on the regional variation in income elasticities and direct rebound effects become available, estimates of the direct and indirect rebound effect could be used in evaluations of energy efficiency programs and policies, such as state Energy Efficiency Resource Standards (EERSs). For that purpose, the use of direct and indirect rebound estimates will likely depend on the geographic scale and intent of the analysis. While the direct rebound effect may be measured by observing household electricity bills before and after an efficiency investment, geographical attribution of the indirect rebound effect using scope 1, 2, and 3 emissions, especially for state or smaller regional scales is more challenging. For electricity efficiency, expenditure reductions in the residential sector may induce increased residential gasoline consumption, as well as higher energy demand in the commercial or industrial sectors, both within and outside the state, due to increased demand for other goods and services. A national-scope EEIO model, such as EIO-LCA, provides limited characterization of regional and sectoral inter-dependencies. However, a lower bound of the indirect rebound at the state-level could be estimated using scope 1 and 2 emissions.

With current policies, the incentive to invest in efficiency may be strongest in those states with higher electricity prices, lower GEFs, and higher indirect rebound effects, which in turn reduce the fewest emissions with energy efficiency. For example, in 2010, California and Minnesota spent \$31 and \$30 per capita on energy efficiency, respectively, compared to spending of \$15 per capita on average across states (ACEEE, 2011), and virtually no efficiency spending in

high-GEF states like West Virginia. The national average results presented in Chapter 3 may underestimate indirect rebound effects in the U.S. because residential energy efficiency investments tend to be made in low-GEF, high electricity-price states with higher indirect rebound effects.

While current policies may cost-effectively reduce energy consumption compared to investment in new power plants, these policies may not cost-effectively reduce CO₂e emissions through energy efficiency investments. Tying federal energy efficiency grants, standards, and incentives to grid emissions factors would help to direct public and private efficiency investments towards regions with high GEFs (Siler-Evans et al., 2012) as would a policy to directly place a price on carbon such as taxes or a cap-and-trade program. Furthermore, federal low-carbon energy or energy efficiency standards, with tradable permits based on emissions, would provide greater incentives for low-cost, high-GEF states to invest in energy efficiency and help the U.S. to cost-effectively reduce CO₂e and air pollution emissions.

4.6 References

- Alfredsson, E.C., 2004. 'Green' consumption no solution for climate change. *Energy* 29, 513-524.
- Aufhammer, M., Blumstein, C., and Fowlie, M., 2008. "Demand side management and energy efficiency revisited." *Energy Journal* 29, 91-104.
- Azevedo, I.L., 2009. *Energy Efficiency in the U.S. Residential Sector: An Engineering and Economic Assessment of Opportunities for Large Energy Savings and Greenhouse Gas Emissions Reductions*. Ph.D. dissertation, Department of Engineering and Public Policy, Carnegie Mellon University, Pittsburgh, PA.
- Berkhout, P. H. G., Muskens, J. C., and Velthuisen, J. W., 2000. "Defining the rebound effect." *Energy Policy* 28, 425-432.
- Binswanger, M., 2001. "Technological progress and sustainable development: what about the rebound effect?" *Ecological Economics* 36, 119-132.
- Bohi, D and Zimmerman, M., 1984. "An Update on Econometric Studies of Energy Demand Behavior." *Annual Reviews of Energy* 9, 105-154.
- Brannlund, R., Ghalwash, T., and Norstrom, J., 2007. "Increased energy efficiency and the rebound effect: Effects on consumption and emissions." *Energy Economics* 29, 1-17.
- Brookes, L., 1990. The greenhouse effect: the fallacies in the energy efficiency solution. 1990, *Energy Policy* 18, 199-201.
- Brookes, L., 2000. "Energy efficiency fallacies revisited." *Energy Policy* 28, 355-366.

- Bureau of Labor Statistics (BLS). Consumer expenditure survey, 2004. Tables: prepublication tables by region. <http://www.bls.gov/cex> (accessed July 31, 2011).
- BLS. Consumer price index, 2002-2004. Tables and Microdata <http://www.bls.gov/cpi/tables.htm> (Accessed June 16, 2012).
- Census Bureau, 2009. American Community Survey (ACS) State Median Income. U.S. Department of Commerce; Washington, DC. (Accessed May 1, 2012). <http://www.census.gov/hhes/www/income/data/statemedian/index.html>
- Carlsson-Kanyama, A., R. Engström and R. Kok, 2005. Indirect and Direct Energy Requirements of City Households in Sweden: Options for Reduction, Lessons from Modeling. *Journal of Industrial Ecology* 9, 221-236.
- Chitnis, M., Sorrell, S., Druckman, A., First, S., and Jackson, T., 2012. Estimating direct and indirect rebound effects for UK households. Sustainable Lifestyles Research Group Working Paper 01-12. http://www.sustainablelifestyles.ac.uk/sites/default/files/projectdocs/estimating_direct_and_in_direct_rebound.pdf.
- Database of state incentives for renewables and efficiency (DSIRE). <http://www.dsireusa.org/> (Accessed July 6, 2012).
- Davis, L., Fuchs, A., and Gertler, P., 2012. "Cash for Coolers." National Bureau of Economic Research Working Paper #18044.
- Druckman, A., Chitnis, M., Sorrell, S., and Jackson, T., 2011. Missing carbon reductions? Exploring rebound and backfire in U.K households. *Energy Policy* 39, 3572-3581.
- Druckman, A. and Jackson, T. The carbon footprint of UK households 1990-2004: A socio-economically disaggregated, quasi-multi-regional input-output model. **2009**, *Ecol. Econ.*, 68, 2066-2077.
- Dubin, J., Miedema, A., and Chandran, R., 1986. Price Effects of Energy-Efficient Technologies: A Study of Residential Demand for Heating and Cooling. *The RAND Journal of Economics* 17, 310-325.
- Economic input-output life cycle assessment model (EIO-LCA). Green Design Institute, Carnegie Mellon: Pittsburgh, PA, 2010. <http://www.eiolca.net> (Accessed March 1, 2011).
- Emissions & Generation Resource Integrated Database, eGRID2007 (year 2005 data); U.S. Environmental Protection Agency: Washington, DC, 2006. <http://www.epa.gov/cleanenergy/energy-resources/egrid/index.html> (accessed April 1, 2012).
- Energy Information Administration (EIA), 2007. "Electricity sales, revenue, prices and customers." In *Electric Power Industry 2007: Year in Review*. U.S. Department of Energy; Washington, DC, 2009. <http://www.eia.gov/electricity/> (Accessed May 2, 2012).
- Environmental Protection Agency (EPA), "Cap and trade: multi-state NOx programs." Washington, D.C., 2012. <http://www.epa.gov/captrade/documents/nox.pdf> (Accessed July 7, 2012).
- Espey, J. and Espey, M., 2004. "Turning on the lights: A Meta-Analysis of Residential Electricity Demand Elasticities." *Journal of Agricultural and Applied Economics* 36, 65-81.
- Freire-Gonzalez, J. 2011. Methods to empirically estimate direct and indirect rebound effect of energy-saving technological changes in households. *Ecological Modelling* 223, 32-40.
- Fronzel, M., Ritter, N., Vance, C., 2010. Heterogeneity in the Rebound Effect. Further Evidence for Germany. *Ruhr Economic Papers*, No. 227.

- Gillingham, K., 2011. How Do Consumers Respond to Gasoline Price Shocks? Heterogeneity in Vehicle Choice and Driving Behavior. Empirical Methods in Energy Economics Proceedings. Dallas, TX.
- Girod, B., de Haan, P., 2010. More or better? A model for changes in household greenhouse gas emissions due to higher income. *Journal of Industrial Ecology* 14, 31–49.
- Greening, L. A., Greene, D. L., and Difiglio, C., 2000. “Energy efficiency and consumption -- the rebound effect -- a survey.” *Energy Policy* 28, 389-401.
- Hanly, M., Dargay, J.M., Goodwin, P.B., 2002. “Review of income and price elasticities in the demand for road traffic.” DTLR final report: London, U.K..
- Hendrickson, C. T., Lave, L. B., Matthews, H. S. *Environmental Life Cycle Assessment of Goods and Services: An Input-Output Approach*. RFF Press: Washington, D.C., 2006.
- Henly, J, Ruderman, H, and Levine, M., 1988. Energy Saving Resulting from Adoption of More Efficient Appliances: A Follow-up. *Energy Journal* 9, 163-170.
- Hertwich, E. G., 2005. “Life cycle approaches to sustainable consumption: A critical review.” *Environmental Science and Technology*, 39, 4673-4684.
- Hertwich, E. G., 2005. Consumption and the rebound effect: An industrial ecology perspective. *Journal of Industrial Ecology* 9, 85-98.
- Hertwich, E. and Peters, G., 2009. “Carbon footprint of nations: A global, trade-linked analysis.” *Environmental Science and Technology* 43, 6414-6420.
- Hunt, L. and Ryan, D., 2011. “Catching on the rebound: Determination of rebound effects in energy economics.” Empirical Methods in Energy Economics conference paper: Dallas, TX.
- International Council for Local Environmental Initiative (ICLEI). (2012) Climate action plans.
- Jaramillo, P., Griffin, W. M., and Matthews, H. S., 2007. “Comparative Life-Cycle Air Emissions of Coal, Domestic Natural Gas, LNG, and SNG for Electricity Generation.” *Environmental Science and Technology* 41, 6290-6296.
- Jones, C. M. and Kammen, D., 2011. “Quantifying carbon footprint reduction opportunities for U.S. households and communities.” *Environmental Science and Technology* 45, 4088-4095.
- Kagawa, S., Nansai, K., Kondo, Y., Hubacek, K., Suh, S., Minx, J., Kudoh, Y., Tasaki, T., and Nakamura, S., 2011. “Role of vehicle lifetime extension in climate change policy.” *Environmental Science and Technology* 45, 1184-1191.
- Khazzoom, J.D., 1980. “The economic implications of mandated efficiency in standards for household appliances.” *Energy Journal* 1, 21-40.
- Kitou, K. and Horvath, A, 2003. “Energy-related emissions from telework.” *Environmental Science and Technology* 37, 3467-3475.
- Kratena, K., Wuger, M., 2008. The full impact of energy efficiency on household's energy demand. Austrian Institute of Economic Research (WIFO).
- Lawrence Livermore National Laboratory, 2008. “State by state energy use in 2008: Energy flowcharts.” Berkeley, CA
https://flowcharts.llnl.gov/content/energy/energy_archive/energy_flow_2008/2008StateEnergy.pdf (Accessed July 2, 2012).
- Lenzen, M., Dey, C.J., 2002. Economic, energy and greenhouse emissions impacts of some consumer choice, technology and government outlay options. *Energ Econ* 24, 377- 403.
- Marriott, J. and Matthews, H. S., 2005. “Environmental effects of interstate power trading on electric consumption mixes.” *Environmental Science and Technology* 39, 8584-8590.
- Mazzi, E. and Dowlatabati, H, 2007. “Air quality impacts of climate mitigation: U.K. policy and passenger vehicle choice.” *Environmental Science and Technology* 41, 387-392.

- McKinsey and Company, 2009. "Unlocking Energy Efficiency in the U.S. Economy." McKinsey Global Institute.
- Mizobuchi, K., 2008. "An empirical study on the rebound effect considering capital costs." *Energy Economics* 30, 2486–2516.
- Murray, C.K., 2011. Income dependent direct and indirect rebound effects from 'green' consumption choices in Australia. Munich Personal RPEC archive, MPRA Paper No. 34973, Munich.
- Nässén, J. and J. Holmberg (2009). Quantifying the rebound effects of energy efficiency improvements and energy conserving behaviour in Sweden *Energy Efficiency* 2, 2201-2231.
- Parfomak, P. and Lave, L., 1996. "How many kilowatts are in a negawatt? Verifying ex post estimates of utility conservation at the regional level." *Energy Journal* 17, 59-87.
- Roy, J., 2000. "The rebound effect: some empirical evidence from India." *Energy Policy* 28, 433-438.
- Safarzynska, K. 2012. "Modeling the rebound effect in two manufacturing industries." *Technological Forecasting and Social Change*. 79, 1135-1154.
- Saunders, H. D., 2000. "A view from the macro side: rebound, backfire, and Khazzoom-Brookes." *Energy Policy* 28, 439-449.
- Sciortino, M., Neubauer, M., Vaidyanathan, S., Chittum, A., Hayes, A, Nowak, S., and Molina, M., Sheppard, C., Jacobson, A., Chamberlin, C., and Mugica, Y., 2011. "The 2011 State Energy Efficiency Scorecard." American Council for an Energy Efficient Economy (ACEEE) Report # E115.
- Siler-Evans, K., Azevedo, I. L., and Morgan, M. G., 2012. "Marginal emissions factors for the U.S. electricity system." *Environmental Science and Technology* 46, 4742-4748.
- Small, K, van Dender, K., 2005. "The effect of improved fuel economy on vehicle miles traveled: Estimating the rebound effect Using U.S. state data, 1966-2001." University of California Energy Institute report# 014.
- Small, K. and Van Dender, K., 2007. "Fuel efficiency and motor vehicle travel: The declining rebound effect." *Energy Journal* 28, 25-51.
- Sorrell, S. and Dimitropoulos, J., 2008. "The rebound effect: Microeconomic definitions, limitations and extensions." *Ecological Economics* 65, 636-649.
- Stone, B., Mednick, A., Holloway, T., and Spak, S., 2009. "Mobile source CO₂ mitigation through smart growth development and vehicle fleet hybridization." *Environmental Science and Technology* 43, 1704-1710.
- Takase, K., Kondo, Y., and Washizu, A., 2005. "An analysis of sustainable consumption by the waste input-output model." *Journal of Industrial Ecology*, 201-219.
- Taylor, L. D. and Houthakker, H.S., 2010. *Consumer Demand in the United States: Prices, Income, and Consumption Behavior*. Third Edition. Springer: New York, NY.
- Thiesen, J., Christiansen, T.S., Kristensen, T.G., Andersen, R.D., Brunoe, B., Greger- sen, T.K., Thrane, M., Weidema, B.P., 2008. Rebound effects of price differences. *International Journal of Life Cycle Assessment* 13, 104–114.
- Thomas, B. A. and Azevedo, I. L., 2012. Direct and indirect rebound effects for the U.S. household with input-output analysis. Under review at *Ecological Economics*.
- Turner, K., 2009. "Negative rebound and disinvestment effects in response to an improvement in energy efficiency in the U.K. economy." *Energy Economics* 31, 648-666.
- Wang, H., Zhou, P., and Zhou, D. Q. , 2012. "An empirical study of the direct rebound effect for passenger transport in urban China." *Energy Economics* 34, 452-460.

- Weber, C., and Matthews, H. S., 2008. Quantifying the global and distributional aspects of American household carbon footprint. *Ecological Economics* 66, 379-391.
- Weber, C. L., Jaramillo, P, Marriott, J., and Samaras, C. , 2010. "Life-cycle assessment and grid electricity: What do we know and what can we know?" *Environmental Science and Technology* 44, 1895-1901.
- Wei, T., 2010. "A general equilibrium view of global rebound effects." *Energy Economics* 32, 661-672.
- Wirl, F., 1997. *The economics of conservation programs*; Kluwer Academic Press: Boston, MA.

4.7 Supporting Information

4.7.1 Overview of Input-Output Analysis

As formalized by Leontief (1970) in his seminal work, the total output of the economy, X , is equal to the sum of intermediate goods and final goods, Y

$$X = AX + Y$$

where A is a linear production function for the economy, expressed in matrix form. This is equivalent to

$$X = (I - A)^{-1}Y$$

where I is the identity matrix, and $(I-A)^{-1}$ is also known as the Leontief inverse, L . The production function, A , can be expressed as industry by industry, commodity by commodity, and industry by commodity matrices. We use the industry-by-commodity structure, L_{IC} in the results reported in this chapter from the purchaser price, 2002 economic input-output life-cycle assessment (EIO-LCA) model for the U.S. (Hendrickson et al., 2006; www.eiolca.net). A can also be expressed in terms of producer and purchaser prices; we use the purchaser version of the model since we are concerned with the embodied energy of final goods demand for households.

Using government-collected industrial energy consumption surveys, a vector of the energy consumption, CO_2e and other environmental emissions per dollar of output, V , can be constructed so that the model measures embodied energy and emissions for the total output of the economy, Z .

$$Z = VLY$$

EIO-LCA makes use of the 428-sector structure of the U.S. input-output tables, which we aggregate into 13 sectors for clarity in the discussion of results, in the following way. We partition the 428 sectors of the economy into 13 aggregated sectors, including energy service

sectors, s , and non-energy service sectors, o , with the indices in a particular aggregate sector represented in the set S_o . We sum over the emissions for all the expenditure categories corresponding to each of the 13 aggregate categories to obtain the emissions per dollar of expenditure other non-energy services, E_o .

$$E_o = \sum_{i=1; i \in S_o; i \neq s}^{428} \frac{\sum_{j=1}^{428} v_j L_{ij} y_j}{y_j}$$

Note that for an electrical efficiency investment, E_o includes spending in gasoline or natural gas, whereas for an improvement in vehicle fuel economy, E_o includes spending in electricity or natural gas, and similarly for natural gas efficiency.

We use the average household expenditures from the 2004 CES in 2002\$ to represent the demand for final goods, Y , by households. The CES is collected in 674 detailed expenditure categories which are classified into the 428 EIO-LCA categories to calculate embodied emissions, and then aggregated into 13 sectors for clarity in interpretation of the results.

4.7.2 U.S. Income Elasticities, Average, and Marginal Spending Shares

Table 4-2: 2004 Expenditure (Income) Elasticities and Marginal Spending for U.S. households

Category	2004 Budget Share	LES- Normalized Expenditure Elasticity	IA- Normalized Expenditure Elasticity	Marginal Spending Share (LES)	Marginal Spending Share (IA)
Food	0.078	0.121	0.363	1%	3%
Shelter	0.179	0.544	0.865	10%	15%
Utilities	0.078	0.137	0.404	1%	3%
Transportation	0.161	2.253	1.264	36%	20%
Health Care	0.039	0.269	0.524	1%	2%
Misc.	0.464	1.096	1.209	51%	56%

Notes: Adapted from Chapter 3. Linear Expenditure System (LES) and Indirect Addilog (IA) expenditure (income) elasticities are from Taylor and Houthakker (2010). Budget shares are from 2004 Consumer expenditure (CE) survey (BLS, 2004). Share of marginal spending is the product of income elasticity and budget share. Income elasticities were weighted by budget share and

normalized to maintain the Engel aggregation property of income elasticities, $\sum_{0=1}^n \epsilon_{0,i}=1$, which implies that households spend within their annual income. Houthakker and Taylor estimated national income elasticities based on 1996-1999 CE data. Given that budget shares across regions differ by less than 3%, we assume that regional variation in income elasticities is small enough to be treated as being the same across regions.

4.7.3 EPA eGRID and NERC region boundary maps

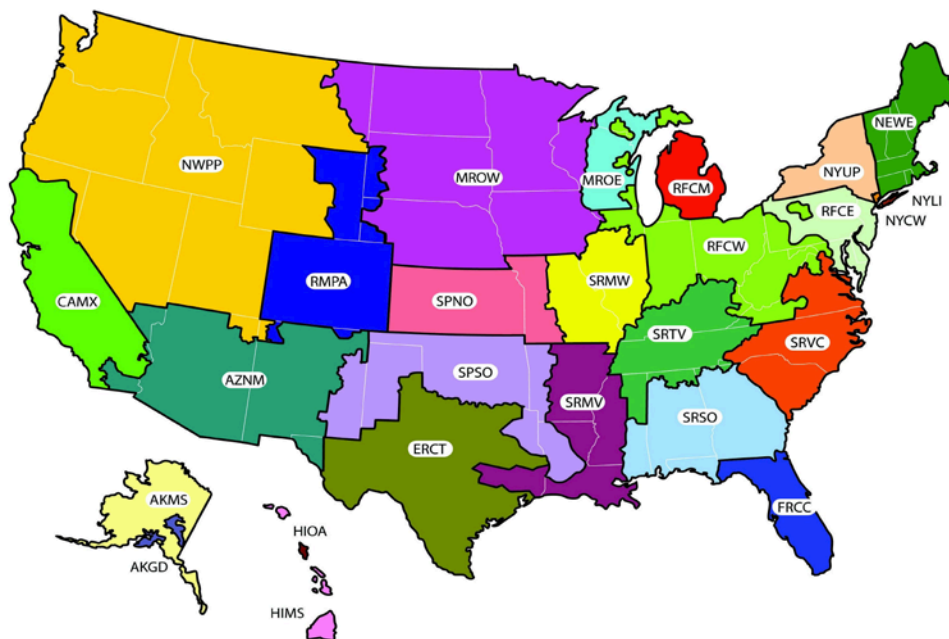

Figure 4-3: EPA eGRID region boundaries.
Source: EPA, 2007.

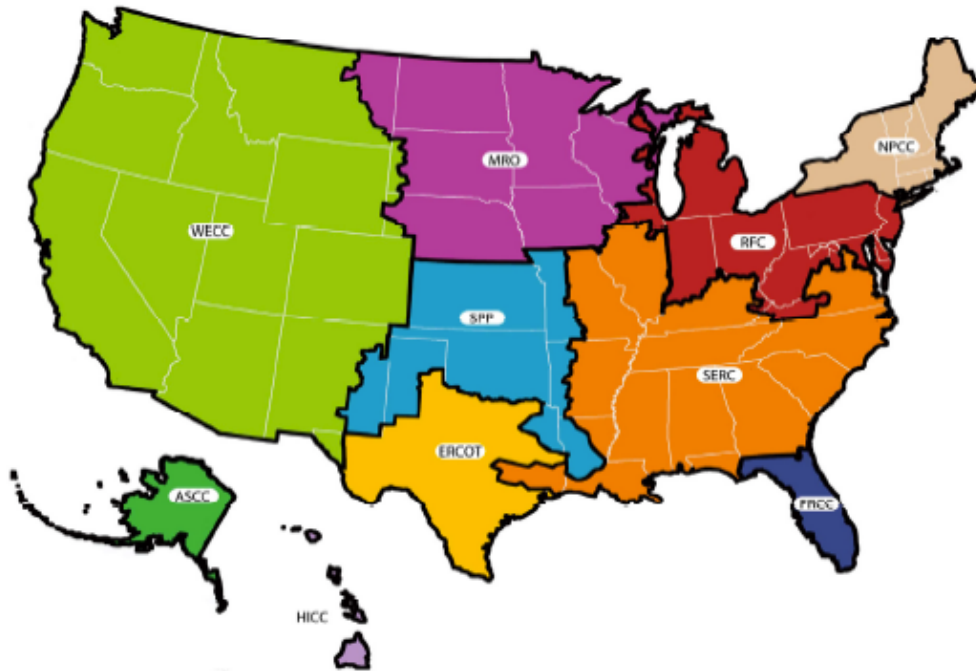

Figure 4-4: NERC region boundaries.
Source: EPA, 2007.

4.7.4 Emissions Impact by Spending Category

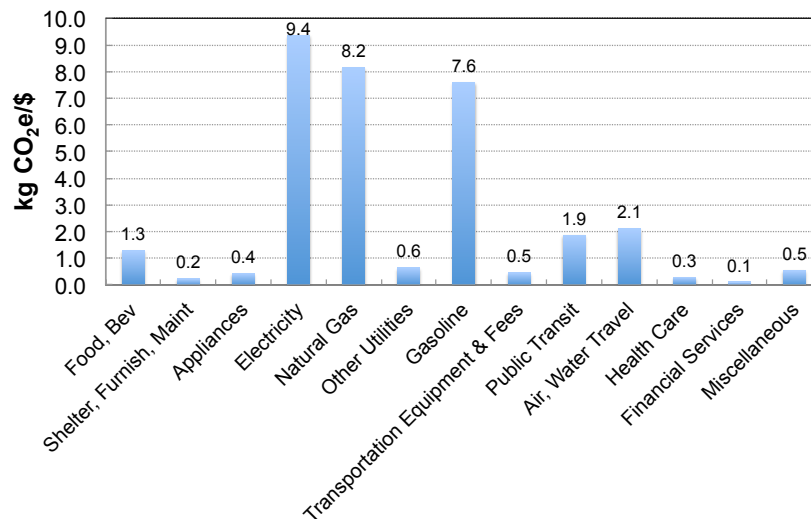

Figure 4-5: U.S. average supply chain (scope 1-3) CO₂e emissions per dollar of expenditure, E_s and E_o, for energy service and other goods at 2004 U.S. average prices in 2002\$.
Notes: The U.S. average emissions intensities for electricity, natural gas, and gasoline are replaced with state-specific energy prices and for electricity, NERC or eGRID-level grid emissions factors for computation of state-level rebound results. Expenditure shares are from 2004 Consumer Expenditure Survey (BLS, 2004) and emissions intensities from www.eiolca.net.

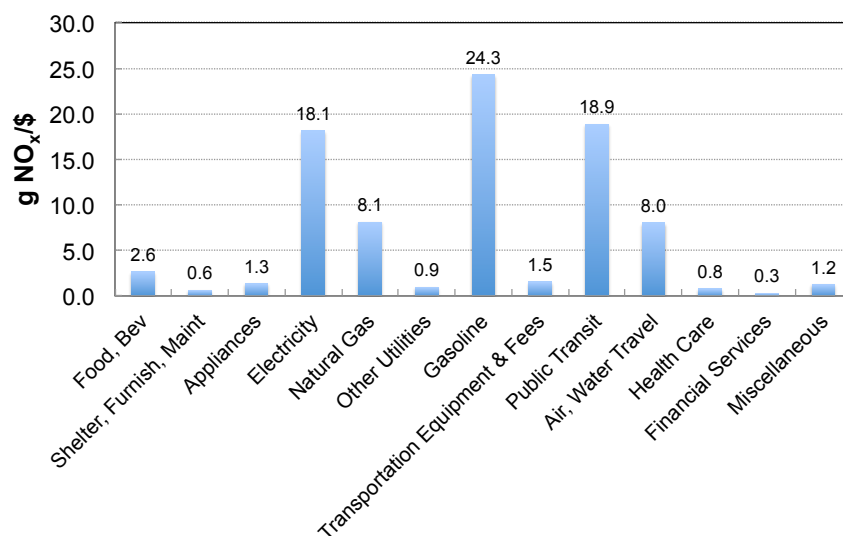

Figure 4-6: U.S. average supply chain (scope 1-3) NO_x emissions per dollar of expenditure, E_S and E_O, for energy service and other goods at 2004 prices in 2002\$.

Sources/Notes: The U.S. average emissions intensities for electricity, natural gas, and gasoline are replaced with state-specific energy prices and for electricity, NERC or eGRID-level grid emissions factors for computation of state-level rebound results. Expenditure shares are from 2004 Consumer Expenditure Survey (BLS, 2004) and emissions intensities from www.eiolca.net.

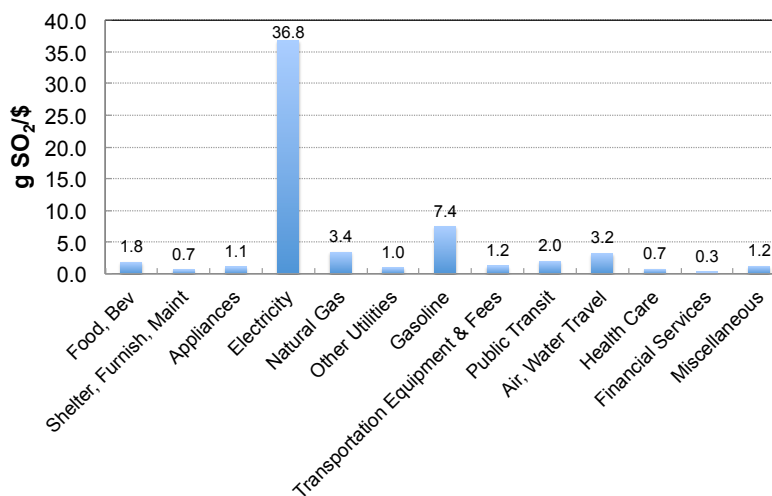

Figure 4-7: U.S. average supply chain (scope 1-3) SO₂ emissions per dollar of expenditure, E_S and E_O, for energy service and other goods at 2004 prices in 2002\$.

Sources/Notes: The U.S. average emissions intensities for electricity, natural gas, and gasoline are replaced with state-specific energy prices and for electricity, NERC or eGRID-level grid emissions factors for computation of state-level rebound results. Expenditure shares are from 2004 Consumer Expenditure Survey (BLS, 2004) and emissions intensities from www.eiolca.net.

4.7.5 Direct and indirect CO₂e rebound results by stateTable 4-3: State-level CO₂e direct and indirect rebound results

State	2004 Median HH Income (2002\$)	Elec Bud. Shr	Gas Bud. Shr.	Elec Price (2002 cts/ kWh)	eGRID								NERC				Direct+Indirect Rebound from Reduction of 1 ton (supply chain) CO ₂ e emissions (i.e. % Rebound)							
					eGRID				NERC				Scope 1-3 emissions				Scope 1-2 emissions							
					GEF kg CO ₂ e/ kWh	HCF tons CO ₂ e/ yr	% CF Elec	% CF Gas	GEF kg CO ₂ e/k Wh	HCF tn CO ₂ e /yr)	% CF, Elec	% CF, Gas	Prp* RD= 8%	min, RD= 2%	max, RD= 13%	min, RD= 2%	max, RD= 13%	min RD= 2%	max RD= 13%	min RD= 2%	max RD= 13%			
AK	52,075	2%	3%	14	0.52	43	14%	27%	0.54	44	14%	27%	21%	16%	30%	16%	29%	8%	22%	7%	21%			
AL	34,407	3%	5%	7.0	0.72	45	36%	29%	0.66	44	34%	30%	13%	8%	21%	9%	22%	5%	19%	6%	19%			
AR	32,890	3%	5%	6.8	0.59	38	29%	31%	0.72	41	33%	29%	14%	10%	23%	8%	21%	6%	19%	5%	18%			
AZ	41,377	3%	4%	9.2	0.64	44	27%	28%	0.51	41	22%	29%	16%	11%	24%	13%	26%	6%	19%	7%	21%			
CA	46,429	2%	4%	13	0.36	39	9%	32%	0.51	40	12%	31%	28%	23%	39%	17%	31%	11%	28%	9%	23%			
CO	48,129	2%	3%	9.2	0.93	46	23%	24%	0.51	41	14%	27%	13%	7%	19%	12%	25%	4%	16%	6%	19%			
CT	52,003	2%	3%	11	0.46	46	13%	27%	0.43	46	12%	27%	21%	16%	29%	17%	30%	8%	22%	8%	22%			
DC	41,181	1%	2%	7.3	0.56	32	17%	20%	0.70	33	20%	19%	14%	8%	20%	7%	18%	4%	15%	3%	15%			
DE	45,283	2%	4%	8.1	0.56	44	23%	28%	0.70	46	27%	27%	15%	10%	23%	9%	21%	6%	19%	5%	18%			
FL	38,151	4%	4%	8.3	0.65	44	32%	27%	0.65	44	32%	27%	15%	10%	23%	10%	23%	6%	19%	6%	19%			
GA	38,507	3%	5%	7.2	0.72	47	32%	29%	0.67	45	30%	30%	14%	8%	21%	9%	22%	5%	18%	6%	19%			
HI	53,308	3%	3%	20	0.86	45	19%	23%	0.86	45	19%	23%	19%	14%	27%	14%	27%	6%	19%	6%	19%			
IA	40,954	2%	4%	8.7	0.88	47	26%	26%	0.88	47	26%	26%	13%	8%	20%	8%	20%	5%	17%	5%	17%			
ID	41,926	2%	3%	6.7	0.45	40	21%	28%	0.51	41	23%	27%	16%	11%	23%	9%	22%	6%	19%	5%	18%			
IL	43,568	2%	3%	8.1	0.79	44	22%	24%	0.70	43	20%	25%	13%	8%	20%	9%	21%	4%	17%	5%	17%			
IN	39,939	2%	4%	7.1	0.74	46	27%	26%	0.69	45	26%	27%	13%	8%	20%	8%	21%	5%	17%	5%	18%			
KS	38,770	2%	4%	7.1	0.97	48	33%	23%	0.87	46	30%	24%	12%	6%	18%	7%	19%	4%	16%	4%	16%			
KY	33,461	3%	5%	5.6	0.74	43	35%	29%	0.68	42	33%	30%	12%	7%	19%	7%	20%	5%	17%	5%	18%			
LA	34,241	4%	5%	7.4	0.59	41	32%	30%	0.72	44	37%	28%	15%	10%	23%	9%	22%	6%	20%	6%	19%			
MA	49,146	2%	3%	11	0.46	42	12%	25%	0.43	42	11%	26%	21%	15%	28%	16%	29%	7%	21%	7%	21%			

													Direct+Indirect Rebound from Reduction of 1 ton (supply chain) CO ₂ e emissions (i.e. % Rebound)								
													Scope 1-3 emissions				Scope 1-2 emissions				
					eGRID				NERC				eGRID		NERC		eGRID		NERC		
State	2004 Median HH Income (2002\$)	Elec Bud. Shr	Gas Bud. Shr.	Elec Price (2002 cts/kWh)	GEF kg CO ₂ e/kWh	HCF tons CO ₂ e/yr	% CF Elec	% CF Gas	GEF kg CO ₂ e/kWh	HCF tn CO ₂ e/yr	% CF, Elec	% CF, Gas	Prp* RD= 8%	min, RD= 2%	max, RD= 13%	min, RD= 2%	max, RD= 13%	min RD= 2%	max RD= 13%	min RD= 2%	max RD= 13%
MD	53,926	2%	3%	7.2	0.58	48	21%	25%	0.70	50	25%	24%	14%	8%	21%	7%	19%	5%	17%	4%	16%
ME	38,905	2%	4%	11	0.44	37	13%	32%	0.41	37	12%	33%	23%	19%	33%	20%	35%	10%	25%	10%	26%
MI	39,877	2%	4%	8.1	0.77	42	21%	28%	0.70	41	19%	28%	14%	8%	21%	9%	21%	5%	18%	5%	18%
MN	53,053	1%	3%	7.7	0.89	53	23%	23%	0.89	53	23%	23%	12%	7%	18%	7%	18%	4%	16%	4%	16%
MO	39,736	2%	4%	6.8	0.92	51	33%	25%	0.75	48	28%	26%	12%	7%	19%	8%	20%	4%	16%	5%	17%
MS	32,605	4%	5%	7.5	0.64	42	33%	32%	0.67	43	34%	31%	15%	10%	24%	10%	23%	7%	20%	6%	20%
MT	31,972	3%	5%	8.6	0.55	35	22%	34%	0.62	36	25%	33%	17%	13%	27%	11%	25%	7%	22%	7%	21%
NC	37,880	3%	4%	7.8	0.57	41	28%	29%	0.69	43	32%	27%	15%	10%	23%	9%	21%	6%	19%	5%	18%
ND	36,999	2%	4%	6.6	0.93	48	35%	24%	0.93	48	35%	24%	12%	6%	18%	6%	18%	4%	16%	4%	16%
NE	41,364	2%	3%	6.7	0.90	49	31%	23%	0.90	49	31%	23%	12%	6%	18%	6%	18%	4%	16%	4%	16%
NH	53,614	2%	3%	12	0.46	47	11%	28%	0.43	47	11%	28%	22%	17%	30%	18%	32%	8%	23%	9%	23%
NJ	52,163	2%	3%	11	0.56	47	14%	27%	0.69	49	17%	26%	18%	13%	26%	11%	23%	7%	20%	6%	19%
NM	37,299	2%	4%	9.5	0.68	37	19%	32%	0.56	36	16%	33%	16%	11%	24%	13%	26%	6%	19%	7%	21%
NV	44,595	3%	4%	11	0.57	43	22%	28%	0.50	42	20%	28%	18%	13%	26%	14%	28%	7%	20%	7%	21%
NY	42,225	2%	2%	14	0.43	35	11%	24%	0.42	35	11%	24%	25%	19%	33%	19%	33%	8%	22%	8%	22%
OH	40,681	2%	3%	8.2	0.75	44	25%	25%	0.70	43	24%	25%	14%	8%	21%	9%	21%	5%	17%	5%	18%
OK	37,216	3%	5%	7.1	0.82	46	33%	29%	0.87	47	34%	29%	13%	8%	20%	7%	20%	5%	18%	5%	18%
OR	38,758	3%	3%	7.8	0.44	36	20%	27%	0.51	37	23%	26%	17%	12%	25%	11%	23%	6%	19%	5%	18%
PA	41,634	2%	3%	9.0	0.61	41	20%	25%	0.70	42	23%	24%	16%	11%	23%	9%	22%	5%	18%	5%	18%
RI	45,340	2%	2%	11	0.46	38	11%	23%	0.43	38	11%	24%	21%	15%	28%	16%	29%	7%	20%	7%	20%
SC	36,313	4%	5%	7.5	0.55	43	29%	32%	0.67	46	33%	30%	16%	11%	25%	10%	23%	7%	21%	6%	20%
SD	38,773	2%	4%	7.4	0.91	48	31%	26%	0.83	46	28%	26%	13%	7%	19%	8%	20%	5%	17%	5%	17%
TN	35,828	3%	4%	6.3	0.72	44	37%	26%	0.66	43	33%	27%	13%	7%	20%	8%	20%	5%	17%	5%	18%
TX	38,942	4%	4%	8.9	0.63	44	29%	30%	0.64	44	29%	29%	16%	11%	24%	11%	24%	6%	20%	6%	20%

													Direct+Indirect Rebound from Reduction of 1 ton (supply chain) CO2e emissions (i.e. % Rebound)								
													Scope 1-3 emissions				Scope 1-2 emissions				
					eGRID				NERC				eGRID		NERC		eGRID		NERC		
State	2004 Median HH Income (2002\$)	Elec Bud. Shr	Gas Bud. Shr.	Elec Price (2002 cts/kWh)	GEF kg CO2e/kWh	HCF tons CO2e/yr	% CF Elec	% CF Gas	GEF kg CO2e/kWh	HCF tn CO2e/yr	% CF, Elec	% CF, Gas	Prp* RD= 8%	min, RD= 2%	max, RD= 13%	min, RD= 2%	max, RD= 13%	min RD= 2%	max RD= 13%	min RD= 2%	max RD= 13%
UT	48,037	2%	3%	7.9	0.45	42	13%	30%	0.51	43	15%	29%	17%	12%	25%	11%	24%	6%	20%	6%	19%
VA	48,231	2%	3%	7.3	0.60	47	25%	27%	0.68	49	27%	26%	14%	9%	21%	8%	20%	5%	18%	5%	17%
VT	44,590	2%	4%	12	0.46	42	11%	31%	0.43	41	12%	31%	23%	18%	33%	19%	34%	9%	25%	10%	25%
WA	47,225	2%	3%	6.9	0.43	41	19%	25%	0.50	42	21%	24%	16%	10%	23%	9%	22%	5%	18%	5%	17%
WI	43,228	2%	3%	8.8	0.81	45	23%	24%	0.79	44	23%	24%	14%	8%	20%	8%	20%	5%	17%	5%	17%
WV	31,400	3%	4%	5.7	0.76	40	37%	27%	0.71	39	35%	27%	12%	7%	19%	7%	19%	4%	17%	4%	17%
WY	42,782	2%	4%	7.9	0.57	43	20%	32%	0.53	42	18%	32%	16%	11%	24%	11%	25%	6%	20%	6%	20%
US-avg	42,141	2%	4%	8.5	0.62	43	23%	27%	0.63	43	23%	27%	17%	12%	25%	11%	24%	6%	20%	6%	19%

Notes: *Prp= proportional spending, defined by Eq. 4-2.

4.7.6 Direct and indirect NO_x rebound results by state

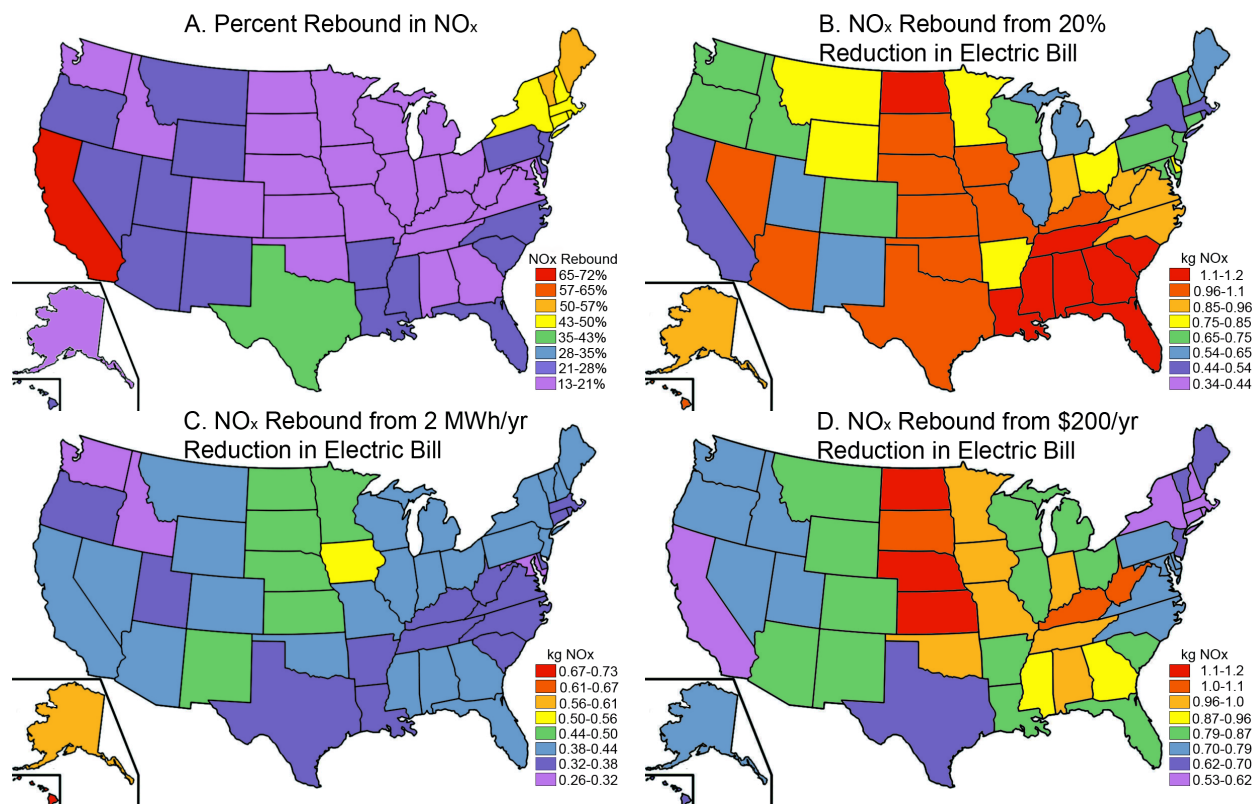

Figure 4-8a-d: Direct and indirect rebound effects in NO_x emissions by state.

Results are shown in (a) relative or percentage terms, (b) for a 20% reduction in annual household electricity bills, (c) for a 2 MWh/yr reduction in electricity consumption, and (d) for a \$200 reduction in annual household electricity bills, and are based on eGRID GEFs.

Notes: There is a larger range in NO_x GEFs and indirect rebound effects across states compared to CO₂ GEFs and rebound effects. However, rebound effects are less than 100%, implying net NO_x emissions savings with efficiency.

Table 4-4: State-level NO_x direct and indirect rebound results

					Direct+Indirect Rebound from Reduction of 1 kg (supply-chain) NO _x emissions (i.e. % Rebound)																
					eGRID				NERC				Scope 1-3 emissions				Scope 1-2 emissions				
State	2004 Median HH Income (2002\$)	Elec Bud. Shr	Gas Bud. Shr.	Elec Price (2002 cts/kWh)	GEF (g NO _x /kWh)	HF (kg NO _x /yr)	% HF, Elec	% HF, Gas	GEF g NO _x /kWh	HF kg NO _x /yr	% CF Elec	% CF Gas	Prp* RD=8 %	min, RD= 2%	max, RD= 13%	min, RD= 2%	max, RD= 13%	min, RD= 2%	max, RD= 13%	min, RD= 2%	max, RD= 13%
AK	52,075	2%	3%	14	1.62	123	21%	30%	1.50	114	15%	32%	16%	12%	27%	12%	26%	11%	27%	8%	23%
AL	34,407	3%	5%	7.0	0.98	108	27%	39%	0.87	98	20%	43%	16%	11%	25%	14%	29%	8%	22%	12%	29%
AR	32,890	3%	5%	6.8	0.71	92	20%	42%	0.99	92	20%	41%	19%	14%	29%	12%	26%	11%	27%	10%	26%
AZ	41,377	3%	4%	9.2	0.96	109	22%	35%	0.69	98	13%	39%	18%	15%	31%	19%	36%	13%	31%	14%	33%
CA	46,429	2%	4%	13	0.29	96	4%	41%	0.69	99	6%	40%	56%	58%	87%	25%	44%	40%	75%	18%	39%
CO	48,129	2%	3%	9.2	1.28	110	18%	32%	0.69	98	8%	35%	15%	10%	24%	17%	33%	7%	21%	11%	28%
CT	52,003	2%	3%	11	0.39	111	6%	36%	0.40	109	5%	37%	37%	35%	57%	35%	57%	23%	48%	23%	48%
DC	41,181	1%	2%	7.3	0.74	75	13%	25%	1.04	75	13%	25%	16%	15%	30%	8%	21%	11%	28%	5%	18%
DE	45,283	2%	4%	8.1	0.74	107	17%	37%	1.04	108	17%	37%	19%	11%	24%	11%	25%	6%	19%	9%	24%
FL	38,151	4%	4%	8.3	0.94	107	26%	35%	0.94	99	21%	38%	17%	13%	28%	13%	28%	11%	27%	11%	27%
GA	38,507	3%	5%	7.2	0.94	112	24%	40%	0.87	104	17%	43%	17%	13%	28%	13%	29%	11%	27%	11%	28%
HI	53,308	3%	3%	20	1.76	117	20%	28%	1.76	111	16%	29%	18%	14%	28%	14%	28%	8%	24%	8%	24%
IA	40,954	2%	4%	8.7	1.68	118	27%	33%	1.62	108	21%	35%	13%	10%	23%	9%	22%	8%	22%	7%	21%
ID	41,926	2%	3%	6.7	0.72	101	18%	35%	0.69	96	13%	37%	17%	8%	22%	14%	28%	7%	21%	10%	26%
IL	43,568	2%	3%	8.1	1.14	103	18%	32%	1.01	96	13%	34%	15%	13%	28%	11%	25%	9%	25%	8%	23%
IN	39,939	2%	4%	7.1	1.17	112	24%	35%	1.04	103	17%	38%	14%	10%	23%	11%	25%	7%	22%	8%	24%
KS	38,770	2%	4%	7.1	1.74	119	32%	30%	1.28	101	20%	35%	12%	7%	20%	9%	22%	6%	19%	7%	21%
KY	33,461	3%	5%	5.6	1.13	107	29%	37%	0.90	94	19%	42%	13%	9%	22%	11%	25%	8%	22%	9%	25%
LA	34,241	4%	5%	7.4	0.72	98	23%	40%	1.00	99	23%	40%	20%	16%	32%	12%	27%	14%	32%	10%	27%
MA	49,146	2%	3%	11	0.39	101	6%	34%	0.40	99	4%	34%	36%	42%	67%	34%	55%	30%	60%	21%	44%
MD	53,926	2%	3%	7.2	0.78	117	16%	33%	1.04	116	16%	33%	16%	12%	26%	9%	23%	8%	24%	7%	21%
ME	38,905	2%	4%	11	0.39	92	6%	42%	0.40	90	5%	43%	42%	34%	56%	41%	66%	21%	45%	30%	60%
MI	39,877	2%	4%	8.1	1.07	101	16%	37%	1.05	96	12%	39%	16%	11%	26%	12%	26%	9%	24%	9%	25%
MN	53,053	1%	3%	7.7	1.68	132	23%	29%	1.62	123	18%	32%	12%	7%	20%	7%	20%	5%	18%	5%	19%

					Direct+Indirect Rebound from Reduction of 1 kg (supply-chain) NOx emissions (i.e. % Rebound)																
					eGRID				NERC				Scope 1-3 emissions				Scope 1-2 emissions				
State	2004 Median HH Income (2002\$)	Elec Bud. Shr	Gas Bud. Shr.	Elec Price (2002 cts/kWh)	GEF (g NOx/kWh)	HF (kg NOx/yr)	% HF, Elec	% HF, Gas	GEF (g NOx/kWh)	HF (kg NOx/yr)	% CF Elec	% CF Gas	Prp* RD=8 %	min, RD= 2%	max, RD= 13%	min, RD= 2%	max, RD= 13%	min, RD= 2%	max, RD= 13%	min, RD= 2%	max, RD= 13%
MO	39,736	2%	4%	6.8	1.26	118	26%	34%	1.03	105	18%	39%	14%	16%	32%	11%	24%	14%	32%	9%	24%
MS	32,605	4%	5%	7.5	0.83	102	24%	42%	0.87	96	19%	45%	19%	9%	22%	15%	31%	7%	22%	13%	31%
MT	31,972	3%	5%	8.6	0.78	90	17%	43%	0.75	85	13%	45%	21%	18%	35%	19%	36%	15%	34%	15%	35%
NC	37,880	3%	4%	7.8	0.73	98	20%	38%	0.87	96	18%	39%	19%	16%	32%	13%	28%	12%	29%	11%	27%
ND	36,999	2%	4%	6.6	1.68	121	34%	30%	1.62	109	27%	34%	12%	39%	61%	7%	20%	21%	46%	6%	19%
NE	41,364	2%	3%	6.7	1.68	122	31%	29%	1.61	110	24%	32%	12%	16%	31%	7%	20%	12%	30%	5%	19%
NH	53,614	2%	3%	12	0.39	114	5%	37%	0.40	112	4%	37%	40%	7%	19%	38%	60%	5%	18%	25%	51%
NJ	52,163	2%	3%	11	0.73	116	10%	35%	1.02	117	10%	35%	23%	38%	61%	14%	29%	25%	52%	10%	26%
NM	37,299	2%	4%	9.5	0.99	94	15%	40%	0.77	88	9%	43%	18%	19%	36%	18%	35%	13%	31%	14%	32%
NV	44,595	3%	4%	11	0.89	108	18%	35%	0.69	99	11%	38%	20%	7%	20%	21%	38%	6%	19%	14%	33%
NY	42,225	2%	2%	14	0.41	83	6%	32%	0.40	82	4%	32%	41%	15%	30%	40%	62%	11%	28%	22%	47%
OH	40,681	2%	3%	8.2	1.17	105	22%	33%	1.04	97	16%	35%	15%	10%	24%	11%	25%	8%	22%	8%	24%
OK	37,216	3%	5%	7.1	1.08	111	25%	39%	1.28	108	22%	41%	15%	11%	26%	10%	24%	10%	26%	8%	24%
OR	38,758	3%	3%	7.8	0.72	91	18%	33%	0.69	86	13%	35%	19%	15%	30%	15%	30%	10%	26%	10%	27%
PA	41,634	2%	3%	9.0	0.85	99	16%	32%	1.04	97	15%	33%	19%	15%	30%	12%	27%	10%	26%	8%	24%
RI	45,340	2%	2%	11	0.39	89	6%	31%	0.40	88	4%	32%	36%	34%	54%	33%	54%	19%	41%	19%	41%
SC	36,313	4%	5%	7.5	0.73	106	21%	42%	0.87	103	19%	44%	20%	17%	33%	14%	30%	15%	34%	12%	30%
SD	38,773	2%	4%	7.4	1.61	119	29%	33%	1.45	107	21%	36%	13%	8%	21%	9%	22%	6%	20%	7%	21%
TN	35,828	3%	4%	6.3	1.13	109	30%	34%	0.88	95	20%	39%	14%	9%	23%	11%	26%	8%	22%	9%	25%
TX	38,942	4%	4%	8.9	0.47	96	13%	43%	0.48	93	10%	45%	30%	28%	48%	27%	46%	22%	46%	21%	45%
UT	48,037	2%	3%	7.9	0.73	108	12%	37%	0.69	104	8%	38%	19%	15%	30%	16%	31%	10%	27%	11%	28%
VA	48,231	2%	3%	7.3	0.81	115	19%	35%	0.90	111	16%	36%	17%	42%	68%	11%	26%	30%	60%	9%	24%
VT	44,590	2%	4%	12	0.39	101	6%	40%	0.40	100	4%	41%	43%	13%	27%	42%	67%	9%	25%	30%	59%
WA	47,225	2%	3%	6.9	0.72	104	17%	31%	0.69	98	12%	32%	17%	12%	27%	13%	27%	8%	23%	8%	24%
WI	43,228	2%	3%	8.8	1.28	107	21%	32%	1.37	102	17%	34%	15%	9%	22%	9%	23%	7%	21%	7%	21%

					Direct+Indirect Rebound from Reduction of 1 kg (supply-chain) NOx emissions (i.e. % Rebound)																
					eGRID				NERC				Scope 1-3 emissions				Scope 1-2 emissions				
State	2004 Median HH Income (2002\$)	Elec Bud. Shr	Gas Bud. Shr.	Elec Price (2002 cts/kWh)	GEF (g NOx/kWh)	HF (kg NOx/yr)	% HF, Elec	% HF, Gas	GEF (g NOx/kWh)	HF (kg NOx/yr)	% CF Elec	% CF Gas	Prp* RD=8 %	min, RD= 2%	max, RD= 13%	min, RD= 2%	max, RD= 13%	min, RD= 2%	max, RD= 13%	min, RD= 2%	max, RD= 13%
WV	31,400	3%	4%	5.7	1.17	98	31%	34%	1.04	87	22%	39%	13%	10%	23%	9%	23%	7%	22%	8%	22%
WY	42,782	2%	4%	7.9	0.89	110	16%	40%	0.74	103	10%	43%	18%	14%	29%	16%	32%	11%	27%	13%	30%
US-avg	42,141	2%	4%	8.5	0.83	104	17%	36%	0.86	99	13%	38%	24%	21%	39%	18%	34%	15%	35%	13%	31%

Notes: *Prp= proportional spending, defined by Eq. 4-2.

4.7.7 Direct and indirect SO₂ rebound results by state

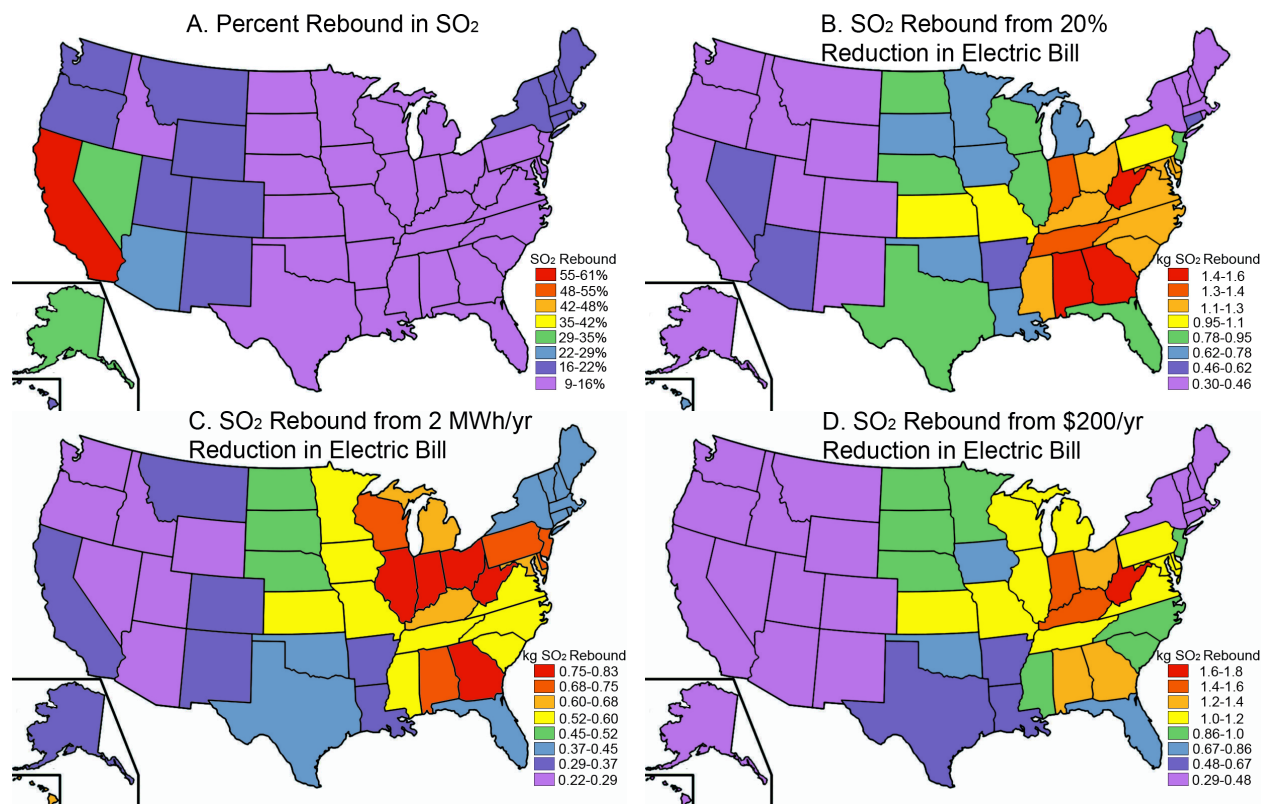

Figure 4-9a-d: Direct and indirect rebound effects in SO₂ emissions by state.

Results are shown in (a) relative or percentage terms, (b) for a 20% reduction in annual household electricity bills, (c) for a 2 MWh/yr reduction in electricity consumption, and (d) for a \$200 reduction in annual household electricity bills and are based on eGRID GEFs.

Notes: There is a larger range in SO₂ GEFs and rebound effects across U.S. states vs. CO₂e GEFs. However, rebound effects are less than 100%, implying that efficiency yields net SO₂ emissions savings.

Table 4-5: State-level SO₂ direct and indirect rebound results

State	2004 Median HH Income (2002\$)	Elec Bud. Shr	Gas Bud. Shr.	Elec Price (200 2 cts/ kWh)	Direct+Indirect Rebound from Reduction of 1 kg (supply-chain) SO ₂ emissions (i.e. % Rebound)																
					eGRID				NERC				Scope 1-3 emissions				Scope 1-2 emissions				
					GEF (g SO ₂ / kWh)	HF (g SO ₂ / yr)	% HF Elec	% HF, Gas	GEF (g SO ₂ / kWh)	HF (g SO ₂ / yr)	% CF, Elec	% CF, Gas	Prp* RD= 8%	min RD= 2%	max RD= 13%	min RD= 2%	max RD= 13%	min RD= 2%	max RD= 13%	min, RD= 2%	max, RD= 13%
AK	52,075	2%	3%	14	0.47	67	8%	17%	0.49	67	9%	17%	37%	28%	41%	27%	40%	7%	21%	7%	21%
AL	34,407	3%	5%	7.0	3.81	128	66%	10%	2.83	106	59%	12%	10%	4%	15%	5%	16%	3%	14%	3%	14%
AR	32,890	3%	5%	6.8	1.04	62	32%	19%	2.60	91	54%	13%	15%	9%	20%	5%	16%	4%	16%	3%	14%
AZ	41,377	3%	4%	9.2	0.50	60	15%	20%	0.49	60	15%	20%	28%	20%	33%	20%	33%	6%	20%	6%	20%
CA	46,429	2%	4%	13	0.24	59	4%	21%	0.49	61	7%	20%	66%	53%	69%	27%	41%	14%	32%	8%	23%
CO	48,129	2%	3%	9.2	1.05	70	17%	16%	0.49	63	9%	17%	17%	10%	22%	19%	32%	4%	16%	5%	19%
CT	52,003	2%	3%	11	1.07	78	18%	15%	1.09	79	18%	15%	18%	12%	23%	11%	23%	4%	16%	4%	16%
DC	41,181	1%	2%	7.3	3.53	80	42%	8%	4.08	85	46%	8%	9%	4%	15%	4%	15%	2%	13%	2%	13%
DE	45,283	2%	4%	8.1	3.53	118	54%	10%	4.08	127	57%	9%	10%	4%	15%	4%	15%	3%	14%	2%	14%
FL	38,151	4%	4%	8.3	1.75	85	45%	14%	1.69	83	44%	14%	13%	7%	18%	7%	18%	3%	15%	3%	15%
GA	38,507	3%	5%	7.2	4.01	132	63%	10%	2.83	107	55%	12%	10%	4%	15%	5%	16%	3%	14%	3%	14%
HI	53,308	3%	3%	20	1.89	80	23%	13%	1.89	80	23%	13%	18%	11%	23%	11%	23%	4%	16%	4%	16%
IA	40,954	2%	4%	8.7	2.56	88	40%	13%	2.66	90	41%	13%	11%	5%	17%	5%	16%	3%	14%	3%	14%
ID	41,926	2%	3%	6.7	0.56	62	17%	18%	0.49	61	15%	18%	20%	13%	25%	15%	27%	4%	17%	5%	18%
IL	43,568	2%	3%	8.1	4.01	103	47%	10%	3.73	99	45%	10%	10%	4%	15%	4%	15%	2%	14%	2%	14%
IN	39,939	2%	4%	7.1	4.44	127	59%	9%	4.08	121	57%	10%	9%	4%	15%	4%	15%	2%	14%	2%	14%
KS	38,770	2%	4%	7.1	3.01	98	49%	11%	2.02	82	39%	13%	10%	4%	15%	5%	17%	3%	14%	3%	14%
KY	33,461	3%	5%	5.6	3.31	109	61%	11%	3.06	104	59%	12%	10%	4%	15%	4%	15%	3%	14%	3%	14%
LA	34,241	4%	5%	7.4	1.06	67	36%	18%	2.58	102	58%	12%	16%	9%	21%	5%	16%	4%	16%	3%	14%
MA	49,146	2%	3%	11	1.07	72	16%	15%	1.09	72	16%	15%	18%	12%	23%	11%	23%	4%	16%	4%	16%
MD	53,926	2%	3%	7.2	3.62	127	51%	9%	4.08	135	54%	9%	9%	4%	15%	4%	15%	2%	14%	2%	14%
ME	38,905	2%	4%	11	1.07	62	18%	19%	1.09	62	19%	19%	20%	13%	25%	12%	25%	5%	18%	5%	17%

Direct+Indirect Rebound from Reduction of 1 kg (supply-chain) SO₂
emissions (i.e. % Rebound)

State	2004 Median HH Income (2002\$)	Elec Bud. Shr	Gas Bud. Shr.	Elec Price (200 2 cts/ kWh)	Direct+Indirect Rebound from Reduction of 1 kg (supply-chain) SO ₂ emissions (i.e. % Rebound)																
					eGRID				NERC				Scope 1-3 emissions				Scope 1-2 emissions				
					GEF (g SO ₂ / kWh)	HF (g SO ₂ / yr)	% HF Elec	% HF, Gas	GEF (g SO ₂ / kWh)	HF (g SO ₂ / yr)	% CF, Elec	% CF, Gas	Prp* RD= 8%	min RD= 2%	max RD= 13%	min RD= 2%	max RD= 13%	min RD= 2%	max RD= 13%	min, RD= 2%	max, RD= 13%
MI	39,877	2%	4%	8.1	3.40	90	43%	13%	4.05	97	47%	12%	10%	4%	16%	4%	15%	3%	14%	2%	14%
MN	53,053	1%	3%	7.7	2.56	100	35%	12%	2.66	101	35%	12%	11%	5%	16%	5%	16%	3%	14%	3%	14%
MO	39,736	2%	4%	6.8	2.87	104	50%	12%	2.52	98	47%	13%	10%	4%	16%	5%	16%	3%	14%	3%	14%
MS	32,605	4%	5%	7.5	2.44	95	55%	14%	2.83	103	59%	13%	11%	5%	17%	5%	16%	3%	15%	3%	14%
MT	31,972	3%	5%	8.6	0.69	52	19%	23%	0.63	51	18%	23%	23%	15%	28%	16%	29%	6%	19%	6%	20%
NC	37,880	3%	4%	7.8	2.67	100	54%	11%	2.83	103	55%	11%	11%	5%	16%	5%	16%	3%	14%	3%	14%
ND	36,999	2%	4%	6.6	2.56	94	49%	12%	2.66	96	50%	12%	10%	5%	16%	4%	16%	3%	14%	3%	14%
NE	41,364	2%	3%	6.7	2.54	95	45%	12%	2.63	96	45%	11%	10%	5%	16%	4%	16%	3%	14%	3%	14%
NH	53,614	2%	3%	12	1.07	79	16%	16%	1.09	79	16%	16%	19%	12%	24%	12%	24%	4%	17%	4%	17%
NJ	52,163	2%	3%	11	3.49	106	39%	12%	4.01	112	42%	11%	11%	5%	16%	4%	16%	3%	14%	3%	14%
NM	37,299	2%	4%	9.5	0.67	54	13%	21%	0.70	55	13%	21%	24%	16%	29%	15%	28%	6%	19%	5%	19%
NV	44,595	3%	4%	11	0.51	62	13%	19%	0.49	62	13%	19%	30%	22%	35%	22%	35%	6%	20%	7%	21%
NY	42,225	2%	2%	14	0.90	59	13%	14%	1.09	61	16%	14%	23%	16%	28%	13%	25%	4%	17%	4%	16%
OH	40,681	2%	3%	8.2	4.44	116	56%	9%	4.08	111	54%	10%	9%	4%	15%	4%	15%	2%	14%	2%	14%
OK	37,216	3%	5%	7.1	1.58	77	38%	17%	2.02	85	44%	15%	13%	6%	18%	6%	17%	3%	15%	3%	15%
OR	38,758	3%	3%	7.8	0.56	56	17%	17%	0.49	55	15%	18%	22%	15%	27%	17%	29%	5%	17%	5%	18%
PA	41,634	2%	3%	9.0	3.76	103	50%	10%	4.07	107	52%	9%	10%	4%	15%	4%	15%	2%	14%	2%	14%
RI	45,340	2%	2%	11	1.07	65	16%	14%	1.09	65	16%	14%	18%	12%	23%	12%	23%	4%	16%	4%	16%
SC	36,313	4%	5%	7.5	2.67	106	56%	13%	2.83	110	58%	12%	11%	5%	16%	5%	16%	3%	14%	3%	14%
SD	38,773	2%	4%	7.4	2.28	87	42%	14%	2.25	86	41%	14%	11%	5%	17%	5%	17%	3%	14%	3%	14%
TN	35,828	3%	4%	6.3	3.08	111	60%	10%	2.85	106	58%	11%	10%	4%	15%	4%	15%	3%	14%	3%	14%
TX	38,942	4%	4%	8.9	1.40	76	37%	16%	1.52	79	39%	16%	15%	8%	20%	8%	20%	4%	16%	4%	16%
UT	48,037	2%	3%	7.9	0.57	66	11%	19%	0.49	65	9%	19%	22%	15%	27%	17%	30%	5%	18%	5%	18%

Direct+Indirect Rebound from Reduction of 1 kg (supply-chain) SO₂
emissions (i.e. % Rebound)

State	2004 Median HH Income (2002\$)	Elec Bud. Shr	Gas Bud. Shr.	Elec Price (200 2 cts/ kWh)	Direct+Indirect Rebound from Reduction of 1 kg (supply-chain) SO ₂ emissions (i.e. % Rebound)																
					eGRID				NERC				Scope 1-3 emissions				Scope 1-2 emissions				
					GEF (g SO ₂ / kWh)	HF (g SO ₂ / yr)	% HF Elec	% HF, Gas	GEF (g SO ₂ / kWh)	HF (g SO ₂ / yr)	% CF, Elec	% CF, Gas	Prp* RD= 8%	min RD= 2%	max RD= 13%	min RD= 2%	max RD= 13%	min RD= 2%	max RD= 13%	min, RD= 2%	max, RD= 13%
VA	48,231	2%	3%	7.3	3.00	116	51%	11%	3.06	118	51%	10%	10%	4%	15%	4%	15%	3%	14%	3%	14%
VT	44,590	2%	4%	12	1.07	69	17%	18%	1.09	69	18%	18%	20%	13%	25%	13%	25%	5%	18%	5%	17%
WA	47,225	2%	3%	6.9	0.56	66	15%	15%	0.49	65	13%	16%	20%	13%	25%	15%	27%	4%	16%	4%	17%
WI	43,228	2%	3%	8.8	3.66	101	46%	11%	3.28	96	44%	11%	10%	4%	15%	5%	16%	2%	14%	3%	14%
WV	31,400	3%	4%	5.7	4.44	123	68%	8%	4.08	116	66%	9%	9%	3%	14%	3%	15%	2%	14%	2%	14%
WY	42,782	2%	4%	7.9	0.77	66	17%	20%	0.60	63	14%	21%	19%	12%	24%	15%	27%	5%	17%	5%	19%
US- avg	42,141	2%	4%	8.5	2.20	88	36%	14%	2.24	88	37%	14%	19%	12%	24%	10%	21%	4%	17%	4%	16%

Notes: *Prp= proportional spending, defined by Eq. 4-2.

Chapter 5: Conclusion

5.1 Summary of Thesis

Globally, governments are providing incentives for and investing in energy efficiency as a means to achieve substantial reductions in energy demand and carbon dioxide and criteria pollutant emissions in a manner that imposes the least costs, creates new jobs, maintains electric system reliability, and sustains economic prosperity. This thesis is intended to help utilities and policymakers understand the benefits of investing in energy efficiency to achieve energy, carbon and criteria pollutant reductions, while accounting for the lower the incremental investment cost for renewables as well as limitations due to rational consumer behavior and rebound effects. Chapter 2 presented an engineering-economic analysis of the costs and systems-level energy efficiency gains from direct current (DC) circuits integrated with LED lighting, solar PV, and batteries. Chapters 3 and 4 present a model of the direct and indirect rebound effect for residential energy efficiency investments and an assessment of its magnitude at the national and state levels. Our research has implications for the many energy efficiency policy instruments favored by the U.S. government, highlights data needs, and prompts further questions about the economics of energy efficiency technologies and policies.

5.2 Energy Efficiency with DC Circuits: Summary, Implications, and Future Work

In Chapter 2, we examined the economics of DC circuits for LED lighting in commercial buildings as a promising broader application of DC circuits beyond telecom facilities and data centers. We found that investment in DC circuits to operate LED lighting in commercial buildings could lower unsubsidized capital costs, on average, by 6% and could lower levelized

annual costs (LACs), on average, by 5% compared with similar lighting systems powered by conventional AC-powered circuits, if it could be undertaken on a large enough scale to overcome the legacy benefits of AC systems. The potential for cost savings would be greater for grid connected PV-powered LED lighting systems, of between 4 to 21% in capital costs and 2 to 21% in LACs compared to a similar grid-connected PV-powered lighting system using conventional AC power. The cost reductions were primarily achieved by improving power conversion efficiencies so that capital investment costs for the PV system could be reduced with a smaller PV system providing the same level of lighting services. However, as the cost of solar panels declines, so do the cost benefits of DC circuits without the development of supporting standards and policies.

These policies include voltage standards for central power supplies powering multiple LEDs, so that power electronics components from the solar PV panel to the LED lighting system can be minimized. Such standards are currently being developed by industry organizations such as Emerge Alliance and IEEE and could help to create a sizable market for centralized DC power supplies, thus bringing DC power supply costs down the experience curve. In addition, workforce training efforts for electrical technicians and subcontractors could help to eliminate mark-ups in installation costs for DC circuits and microgrids. Lastly, safety standards for DC wiring need to be in place so that adequate insulation and circuit protection is in place to mitigate the arcing and electrical fire risks with DC circuits.

The future development of DC circuits and microgrids could accelerate with the creation of a market for high-power rectifiers. Such a market could develop with further application of DC circuits for other end-uses such as heating, ventilation, and air conditioning (HVAC) systems, or

with other types of distribution generation such as microturbines. The development of plug-in hybrid electric vehicle charging infrastructure at the home, office, or in standalone stations may be another possible DC power application. In addition, further research on the reliability benefits and safety risks could support the development of the standards that need to be in place to enable market investment and innovation in alternative DC-based architectures.

5.3 Residential Rebound Effects: Summary, Implications, and Future Work

In Chapter 3 we developed a model of the indirect rebound effect, or re-spending energy cost savings on other goods, given an estimate of the direct effect, or increased usage of an efficient appliance using microeconomics, U.S. Consumer Expenditure survey data, and the economic input-output life cycle assessment model (EIO-LCA) for the U.S. in 2002. We find that the indirect rebound varies between 5-15% in primary energy and CO₂e emissions, depending on the fuel saved with efficiency, and can be as high as 30-40% in NO_x or SO₂ emissions, for the case of natural gas efficiency. In addition, we also found that as the U.S. electric grid becomes less-carbon intensive, or in households with large transportation demands, the indirect rebound effect will be larger.

We use this insight to examine the state-level variation in indirect rebound effects from electricity efficiency, given an estimate of the direct effect in Chapter 4. We apply the model to average state-level electricity and gasoline expenditures per household augmented with regional expenditure data on other goods from the U.S. Consumer Expenditure survey. We find that CO₂e direct and indirect rebound effects vary across states between 6-40% when including scope 1, 2, and 3 emissions, and between 4-30% when including only scope 1 and 2 emissions. There is an even greater variation in rebound effects in NO_x and SO₂ emissions across states. However, states

with a higher percentage rebound effect also often have low grid emissions factors (GEFs), so that the associated rebound in emissions is small.

These moderate direct and indirect rebound results suggest that energy efficiency policies will be able to reduce energy consumption, CO₂e, and criteria air pollution effects, despite facing headwinds from more usage (direct rebound) and re-spending effects (indirect rebound). A key driver of the indirect rebound from electricity efficiency is re-spending on transportation, so policies to support sustainable lifestyles and transportation modes will be important. Percentage indirect rebound effects in CO₂e, NO_x, and SO₂ from electricity efficiency are especially high in states in the Northeast and California with high electricity prices and low-emissions electricity. While California and the Northeastern states may be able to achieve considerable energy cost savings and reliability benefits from investing in electrical energy efficiency, other states with high-carbon electricity may possess more cost-effective options to reducing emissions. Policy mechanisms that add geographic flexibility, such as tradable efficiency credits, such as the EU's white certificates program, could also be useful to achieve low-cost emissions reduction. However, the regional variation in CO₂e and criteria emissions factors and rebound effects for electricity imply that efficiency permits should be allocated on the basis of emissions, rather than energy reduced, to provide stronger incentives for states with high-carbon electricity to invest in energy efficiency. A federal low-carbon electricity standard, economy-wide cap and trade program, or carbon tax could achieve similar results while adding greater flexibility for states to choose between investments in energy efficiency, low-carbon energy, and emissions abatement opportunities in multiple sectors.

For local and state governments implementing climate action plans and EERS, efficiency investments can be targeted to those end-uses with fixed duty cycles (i.e. refrigerators, streetlights) where direct rebound effects are expected to be small. In addition, accounting for direct rebound effects can ensure that governments make a realistic assessment of the costs and benefits of energy efficiency investments. However, indirect rebound effects are more difficult to consider at the city or state level given the national scope of economic input-output lifecycle assessment (EIO-LCA) model used to assess rebound effects in Chapters 3 and 4. From a local or state regulator's perspective, the consequences of indirect rebound effects may not be observable or measurable directly in local or state energy statistics, which is especially true for the case of NO_x or SO₂ emissions.

National efficiency policies such as appliance and vehicle standards can take direct and indirect rebound effects to adjust their energy savings estimates. In addition, the regional variation in direct and indirect rebound effects suggests that differentiation of appliance standards may be warranted. The 2011 federal appliance standards for furnaces, heat pumps, and central air conditioners seem to be going in this direction, with different standards proposed for various climate zones of the country (DOE, 2011).

Current estimates of the direct rebound effect in electricity end-uses are from small-scale studies. A systematic assessment of direct and indirect rebound effects by end-use and region for electricity efficiency has been hampered by the lack of data on metered electricity consumption and appliance efficiency. As sensor data and smart meters become more ubiquitous, researchers may be able to construct of the types of data needed for rebound estimates. In addition, the studies presented in this thesis represent first-order simulations of indirect rebound effects only.

The ideal data set would require a panel of households making efficiency investments and include a control group. These data are likely difficult and expensive to obtain, for what looks to be a modest effect in most parts of the country.

Simulations of the type presented in this thesis and in the literature may offer a more feasible approach, than panel studies, to estimating the indirect rebound effect. Tax policy analysts frequently assess the multiplier effects of different tax options, a similar approach may be warranted for energy and environmental policy to account for the impacts of a policy beyond the sector being regulated. While existing analytical efforts to support energy efficiency policies do account for manufacturer and job impacts, the effects of efficiency programs and incentives on household consumption and carbon and environmental footprints are yet to be fully explored.

This research identifies topics worthy of further study to extend and improve the neoclassical economics-based direct and indirect model presented in Chapter 3, such as:

- Econometric studies of income and price elasticities for systems of goods in a framework consistent with the demand for energy services rather than energy fuels by incorporating proxies for the improvement in technology over time
- Strategies that incorporate capital costs, savings, and the environmental impact of investment in an indirect rebound model
- Further empirical study of the distribution of indirect rebound effects over individuals, regions, and time using disaggregated data and with elasticities measured for the individual

More generally, one can question the assumption of rational, optimizing behavior on the part of households and study alternative explanations for the direct and indirect rebound effect. For example, if consumers have a mental account for energy or environmental actions, energy cost savings may yield different spending patterns than other sources of income. Other deviations from “rationality”, such as time-inconsistent preferences, hyperbolic discounting, present bias, and other factors may be especially important to consider for study of the decision to invest in

efficiency in the first place. Future research could quantify the importance of these effects relative to a simple change in the price of energy services as drivers of consumer energy usage and spending patterns.

In addition, further research on direct and indirect rebound effects in the commercial and industrial sectors from a microeconomic perspective would complement macroeconomic estimates from economy-wide rebound studies. Rebound effects in developing countries are also important as these countries will contribute to much of the growth in future energy demand and have the greatest unmet needs for energy services. In developing countries, targeting efficiency programs towards those end-uses with fixed duty cycles may be especially useful to achieve emissions reduction benefits and avoid the chance of backfire.

While this dissertation focuses on direct and indirect rebound effects from residential investments in energy efficiency from a microeconomic perspective, there is a wide body of literature that considers economy-wide rebound effects, mostly in the commercial and industrial sectors, from a macroeconomic perspective (Brookes, 1990, 2000; Howarth, 1997; Saunders, 1992, 1998, 2000, 2010; Allan et al., 2007; Wei, 2010). In economy-wide rebound studies, analysts must be careful to separate changes in energy demand due to new attributes of improving technology, such as the directional lighting and small form factors for LED lamps vs. CFL and incandescent lamps. These new technological attributes may induce greater energy demand for reasons other than the higher efficiency of LEDs compared to CFLs and incandescent lamps. For example, an economy-wide rebound study of the U.S. (Saunders, 2010) uses data that do not make the distinction between energy efficiency improvements and general technology change, which induces both substitution effects and improvements in total factor productivity (Sorrell,

2007). Without detailed historical indices of the changes in efficiency and other attributes of technology over time, it may not be possible to distinguish economy-wide rebound effects from changes in energy demand under general types of technological change. Turner (2012) argues that there are both positive and negative drivers for economy-wide rebound effect that call into question the value of aggregating these various technological dynamics into a single rebound parameter.

The simplest measure of the rebound effect, the difference between potential and actual energy savings expressed as a percentage of potential energy savings ($R=1-AES/PES$), comes from efficiency program evaluation literature (Sommerville, 2007) which is most concerned with deviations from engineering estimates due to mis-specified or mis-calibrated engineering models (Vine et al., 1994; Fowlie et al., 2012) or behavioral change due to the direct rebound effect. The indirect rebound effect can be measured in a similar framework, i.e. $R=1-AES/PES$, if efficiency program evaluators, utilities, and policymakers are willing to expand the scope of PES to consider supply-chain energy and emissions effects through an input-output analysis. However, for the economy-wide rebound effect, PES is difficult to measure or define without detailed historical efficiency data in an economy-wide context. In the economy-wide context, aggregating to a single rebound estimate may be over-simplistic and may obscure more important dynamics of energy demand under technological change. As the world comes to rely upon energy efficiency and technological improvements to make large reductions in energy demand in the next 20 years, it will be important to understand these dynamics in a holistic manner.

5.4 References

- Allan, G., Gilmartin, M., and Turner, K., 2007. UKERC Review of Evidence for the Rebound Effect. Technical Report 4: Computable general equilibrium modeling studies. Working Paper. UK Energy Research Centre.
- Brookes, L., 1990. The greenhouse effect: the fallacies in the energy efficiency solution. *Energy Policy* 18, 199-201.
- Brookes, L., 2000. Energy efficiency fallacies revisited. *Energy Policy* 28, 355-366.
- Department of Energy (DOE), 2011. "Residential Furnaces and Central Air Conditioners and Heat Pumps Direct Final Rule."
http://www1.eere.energy.gov/buildings/appliance_standards/residential/residential_furnaces_ac_hp_direct_final_rule.html
- Fowlie, M, Wolfram, C., and Greenstone, M., 2012. "Reconcilable differences? Examining the gap between engineering projections and ex post realized gains from energy - efficiency investments." Lawrence Berkeley National Laboratory Seminar, July 27.
- Howarth, R., 1997. Energy Efficiency and Economic Growth. *Contemporary Economic Policy* XV, 1-9.
- Saunders, H.D., 1992. A view from the macro side: rebound, backfire, and Khazzoom-Brookes. *Energy Policy* 28, 439-449.
- Saunders, H. D., 2000. A view from the macro side: rebound, backfire, and Khazoom-Brookes. *Energy Policy* 28, 439-449.
- Saunders, H. D., 2008. Fuel conserving (and using) production functions. *Energy Economics* 30, 2184-2235.
- Saunders, H. D., 2010. Historical evidence for energy consumption rebound in 30 U.S. sectors and a toolkit for rebound analysts. The Breakthrough Institute Blog.
<http://thebreakthrough.org/blog/Historical Evidence Article 11-11-10.pdf>.
- Sommerville, M., 2007. UKERC Review of Evidence for the Rebound Effect. Technical Report 1: Space heating energy efficiency program evaluation report. Working Paper. UK Energy Research Centre.
- Sorrell, S., 2007. The Rebound Effect: an assessment of the evidence for economy-wide energy savings from improved energy efficiency. UK Energy Research Centre Technical Report.
- Turner, K., 2009. Negative rebound and disinvestment effects in response to an improvement in energy efficiency in the U.K. economy. *Energy Economics* 31, 648-666.
- Turner, K., 2012. "'Rebound' effects from increased energy efficiency: a time to pause and reflect." Stirling Economics Discussion Paper, 2012-15.
<http://www.stir.ac.uk/media/schools/management/documents/workingpapers/SEDP-2012-15-Turner.pdf>.
- Wei, T., 2010. A general equilibrium view of global rebound effects. *Energy Economics* 32, 661-672.
- Vine, E., Misuriello, H., and Hopkins, M. E., 1994. A Research Agenda for Demand-Side Management Impact Measurement. *Energy* 11, 1103-1111.