



IW Engine Generator / Heat Recovery Trnsys Model

Flore Marion
December, 11th 2007

Carnegie Mellon SCHOOL OF ARCHITECTURE
CENTER FOR BUILDING PERFORMANCE AND DIAGNOSTICS



Modeling objective:

- Last energy supply system in the IW : Biodiesel engine
- Provides heat by the coolant and the exhaust to the IW heating and cooling devices

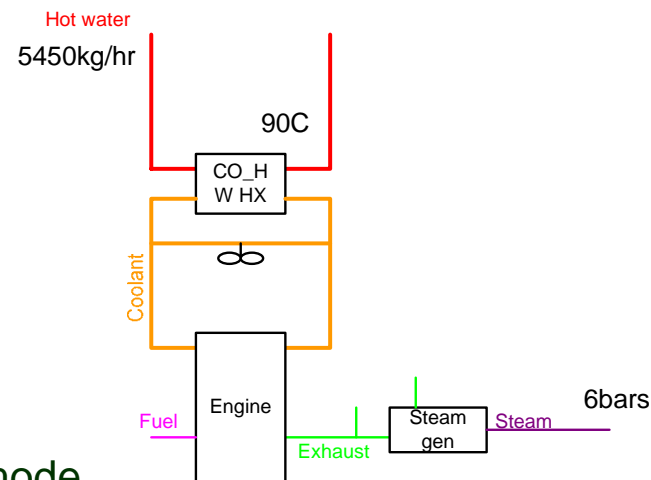

- Trnsys modeling objective :
 - anticipates the dynamic of the whole system in different mode
 - Evaluates the cogeneration system performance
 - By it self
 - Integrated to the iWESS
 - Points out the possible critic situations
 - Compares to other configuration





plan

1. TRNSYS Model explanation
2. Maximum efficiency
3. Summer Case
4. Winter Case
5. Future Work



1. TRNSYS Model explanation

Flow Diagram which on TRNSYS interface is based

Cogeneration system

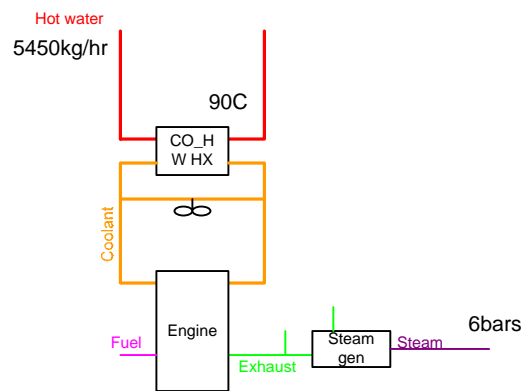

IWESS cogeneration system connections

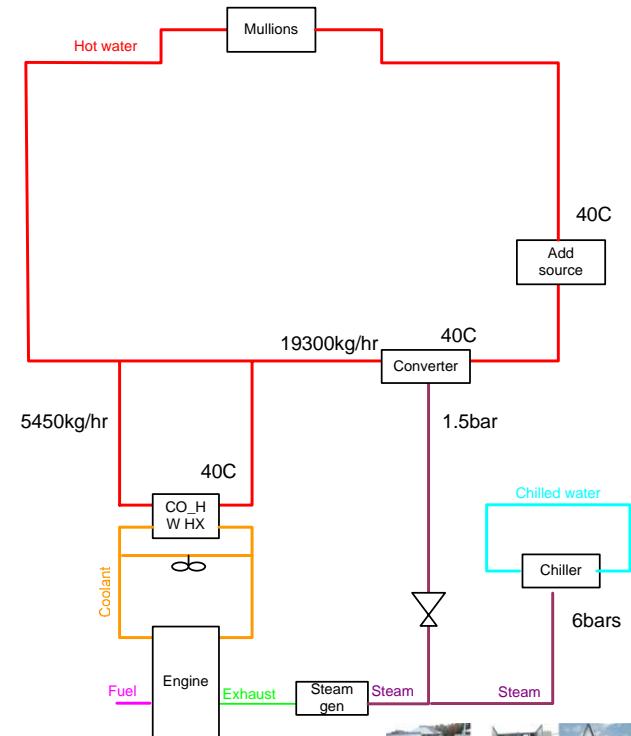

→ The modeling issue is not only on the engine performance but more on its interactions with the Building (energy thermal balance..)



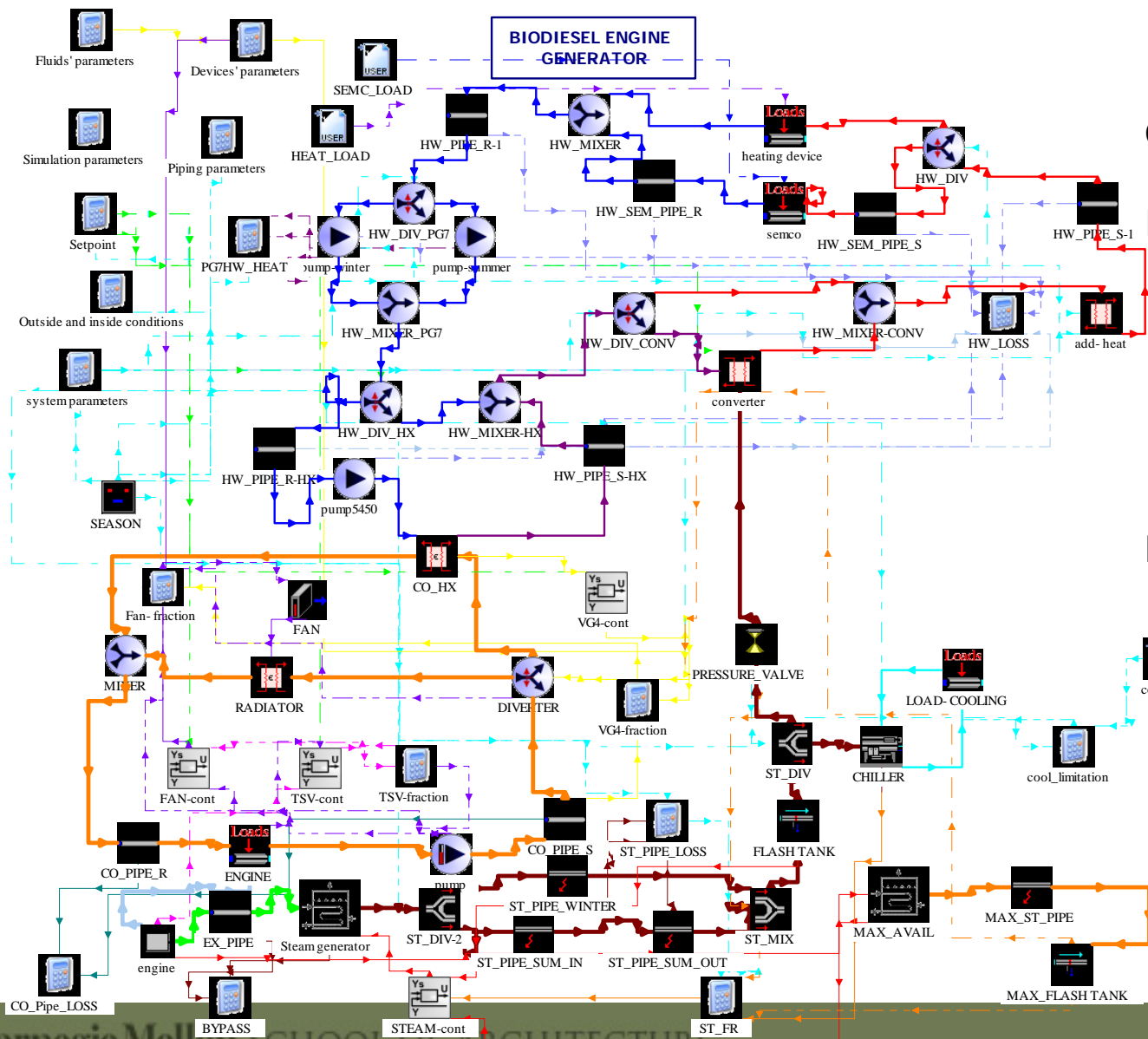

Compare to reality trnsys model,
Includes:

- Fluids specifications
- Device nominal specifications
- IW loads
- Control strategy
- Pumps

Needs:

- Additional heat source
- Specific steam branch



2. Optimal Performance

Specification:

-Design mode-

Hot water set point : **90C**

Steam pressure : **6bar**

No heat wasted

by the radiator nor

by the exhaust by pass

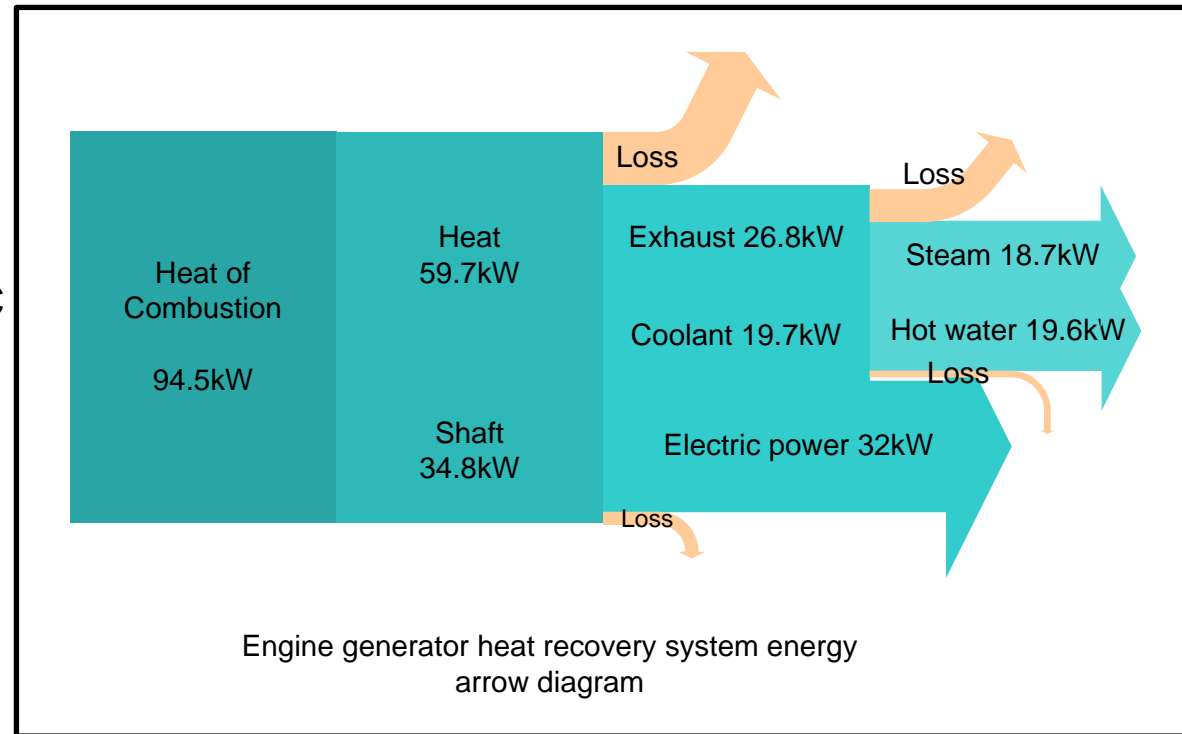

→Evaluation of the maximum recoverable heat

Energy recovered: **74.5%**

Legislation criterion performance:

$$\frac{\text{Electric output} + \frac{1}{2} \text{ used thermal output}}{\text{Fuel input}} = \mathbf{54.2\%} > \mathbf{42.5\%}$$



3. Winter Performance

Mean heating load : **15.4kW** (0 to 49.7kw)

Mode specifications:

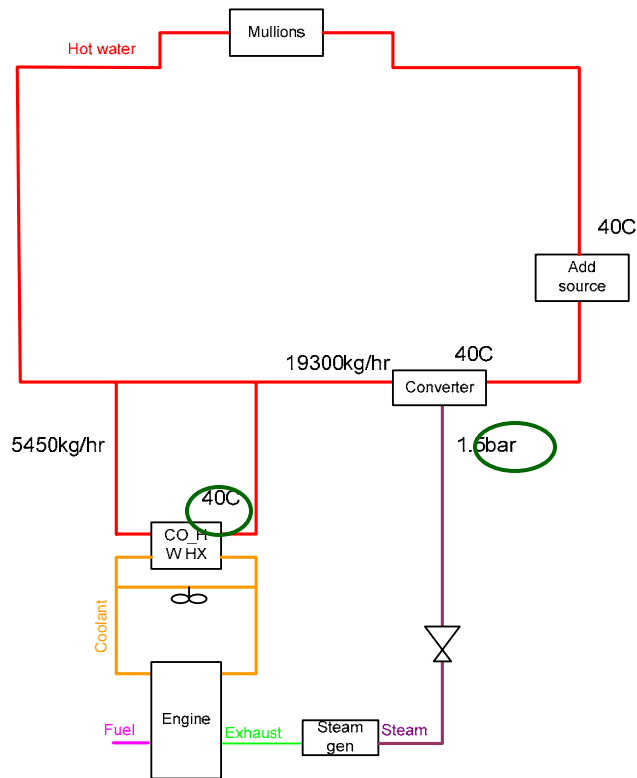

Jan 15-20th

• Results:

- The cogeneration system covered:
- **63.2%** of the heating demand provided by the **converter**.
- **24%** of the heating demand provided by the **coolant hot water heat exchanger**.

• Efficiency:

- **11.4%** of fuel energy is transferred to **steam**
- **3.9%** is transferred to **hot water by the HX**
- **33.9%** is converted to **electric power**

$$\frac{\text{Electric output} + \frac{1}{2} \text{ used thermal output}}{\text{Fuel input}} = 41.6 < 42.5\%$$



4. Summer Performance

Mode specifications:

Mean regeneration load :**21kW** (13 to 26kw)

Mean cooling load :**14kW** (0 to 27kw)

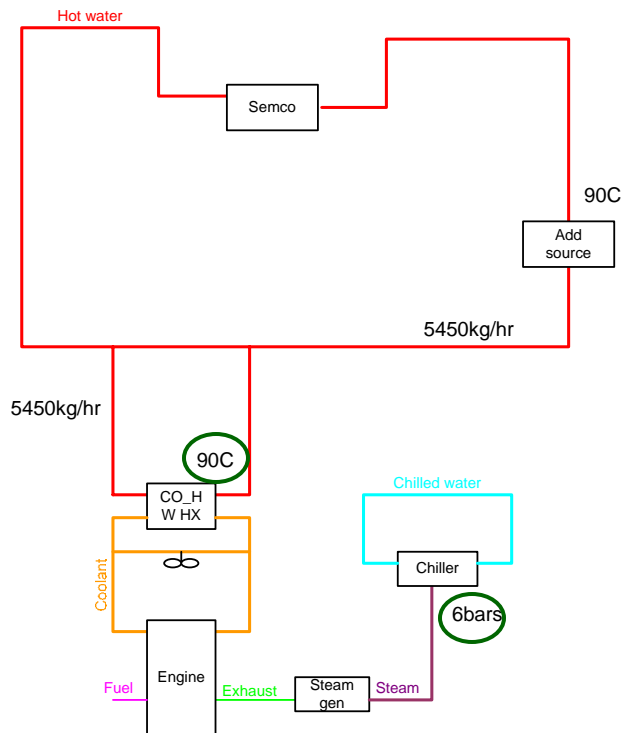

July1-5th

Results:

The cogeneration system covered:

- **77.1%** of the **cooling** load
- **90.4%** of the **regeneration** load

Efficiency:

- **15.9%** of fuel energy is transferred to **steam**
- **20.4%** is transferred to the **hot water**
- **33.9%** is converted to **electric power**

$$\frac{\text{Electric output} + \frac{1}{2} \text{ used thermal output}}{\text{Fuel input}} = \mathbf{52.0\%} > 42.5\%$$

→ **The system satisfies the legislation !**





Conclusion

- This cogeneration system is performing
- System more efficient for the summer operation (design specification)

Design Optimisation

- Find a way to recover more energy in the winter mode to meet the legislation requirement all year long
- Connect more hot water fed devices to the HW loop so that more energy is recovered (the peak will be covered by the steam grid)

Future work

- Study different part load models (With the exhaust temperature information)
- Defined a control strategy to adjust the engine production to the building demand

