

# Overall system performance modeling: Solar thermal cooling/heating of the IW

---

Sophie Masson, Ming Qu

IWESS Presentation

October 4th 2006



## *PURPOSE OF THE PROJECT*

---

- Extend the previous performance modeling : create a detailed model given the characteristics of the existing devices and the system operation (BROAD solar thermal system installed in August 2006 and LTG fan coils)
- Assist the design of the solar thermal system (orientation, insulation thickness of the piping)
- Predict the system energy performance and optimize the system based on different parameters (volume and insulation thickness of a cold/hot storage tank) with TRNSYS



# CONTENTS

---

1- Design of the solar thermal system

2- Optimization of the existing system



1. System design
2. System optimization

# 1. SYSTEM DESIGN

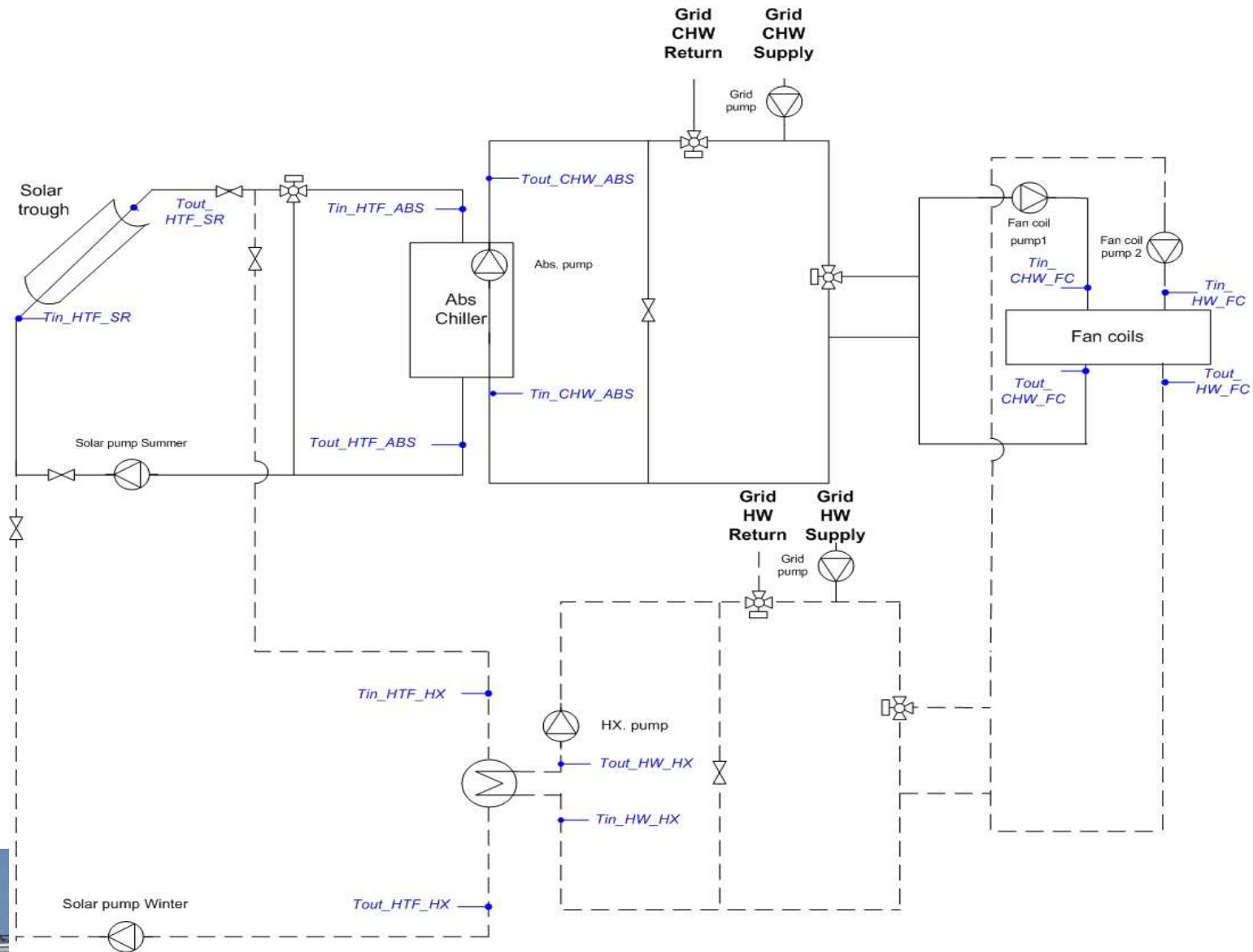

1. **System design**
2. System optimization

## 1. SYSTEM DESIGN

---

### Assumptions :

- ▶ **Solar collector** : - parabolic trough (with one axis solar tracking system)

Area = 52 m<sup>2</sup>

$$= 0.587 - 0.01769 \Delta T/SR$$

$$\Delta T = T_{fluid} - T_{ambient} \text{ (}^\circ\text{C)}$$

SR : instantaneous solar radiation (W/m<sup>2</sup>)

- ▶ **HTF in solar collection loop** : Propylene glycol-water mixture (50%)
- ▶ **Absorption chiller** : double effect hot water & gas fired
- ▶ **Thermal storage** : hot/cold water storage tank (after the solar collection loop)

### Sensitivity analysis

- ▶ **Design variables**

- Orientation of the solar trough
- Insulation thickness of the piping
- Volume and insulation thickness of the storage tank



1. **System design**
2. System optimization

## 1. SYSTEM DESIGN : orientation of the solar trough (1)

### Orientation : Solar trough with NS axis EW tracking vs. EW axis NS tracking

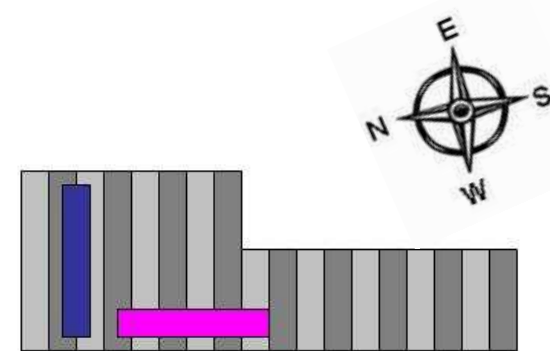
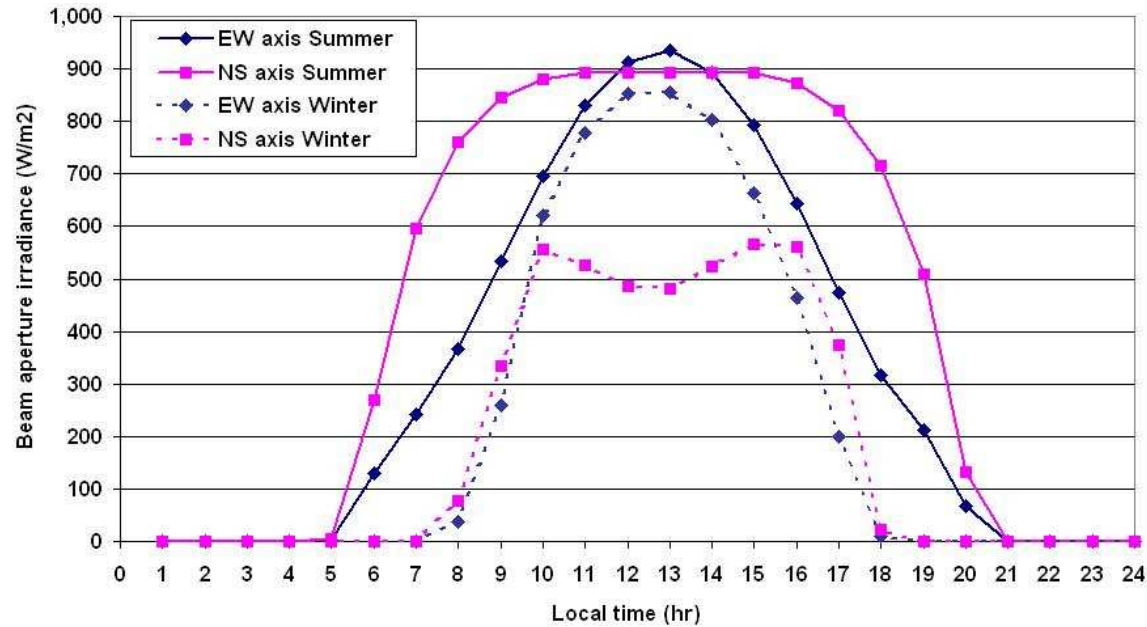

Period	Beam aperture irradiation (kWh/m <sup>2</sup> )		Relative difference (%) (NS-EW)/EW
	EW axis	NS axis	
SUMMER	583	726	25
WINTER	304	273	-11
YEAR	887	999	13



1. **System design**
2. System optimization

## 1. SYSTEM DESIGN : orientation of the solar trough (2)

### Influence of the orientation of the solar troughs on the system performance

Case	A	B
Orientation	EW axis	<b>NS axis</b>
Insulation thickness of the solar collection loop	3"	<b>3"</b>
Volume of the storage tank	-	-
Insulation thickness of the storage tank	-	-
Solar ratio in summer (%)	37.8	<b>61.4</b>
Solar ratio in winter (%)	8.4	<b>7.5</b>

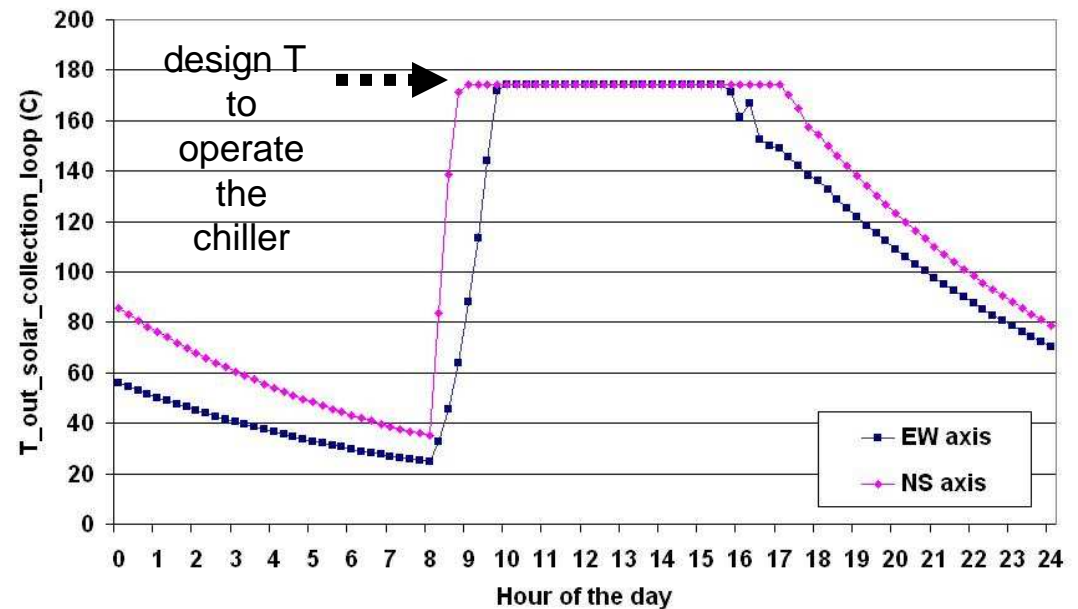

Summer



1. **System design**
2. System optimization

## 2. SYSTEM DESIGN : insulation of the piping

### Influence of the insulation thickness of the piping on the system performance

Case	<b>C</b>
Orientation	<b>EW axis</b>
Insulation thickness of the solar collection loop	<b>From 0 to 5"</b>
Volume of the storage tank	-
Insulation thickness of the storage tank	-
Solar ratio in summer (%)	<b>30.6 – 39.5</b>
Solar ratio in winter (%)	<b>7.2 – 8.6</b>

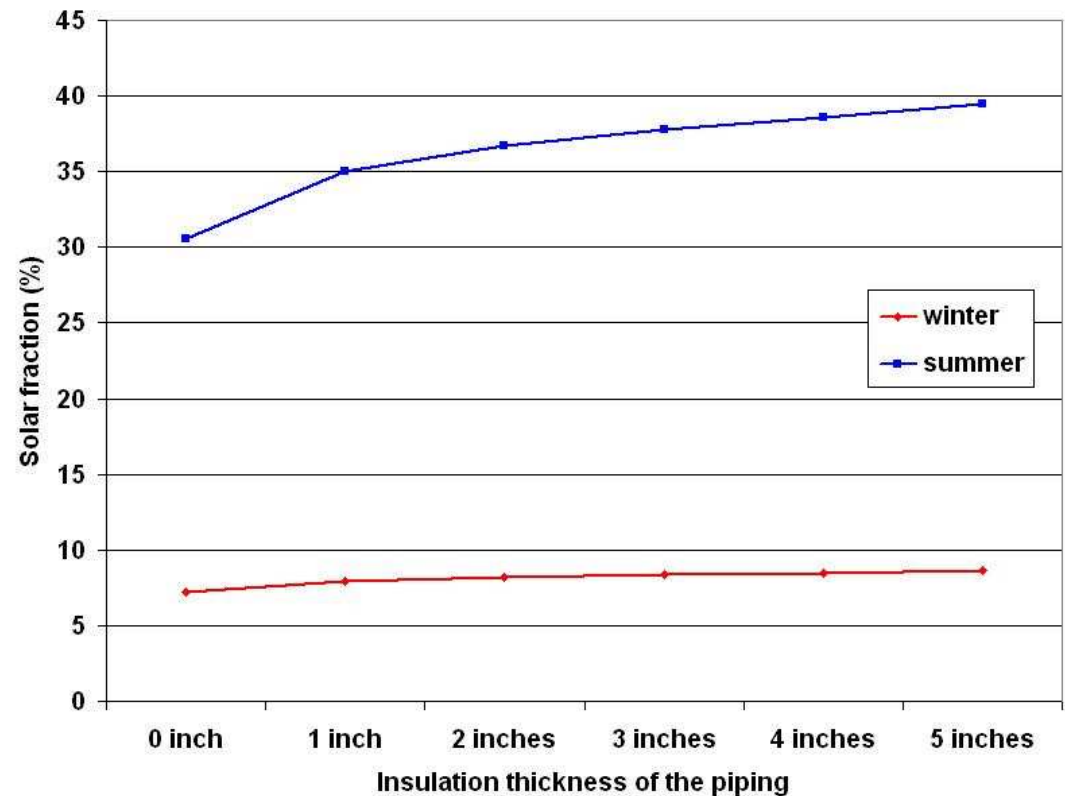

1. **System design**
2. System optimization

## 2. SYSTEM DESIGN : Base Case

Case	Base case
Orientation	EW axis
Insulation thickness of the solar collection loop	3"
Volume of the storage tank	-
Insulation thickness of the storage tank	-
Solar ratio in summer (%)	<b>37.8</b>
Solar ratio in winter (%)	<b>8.4</b>

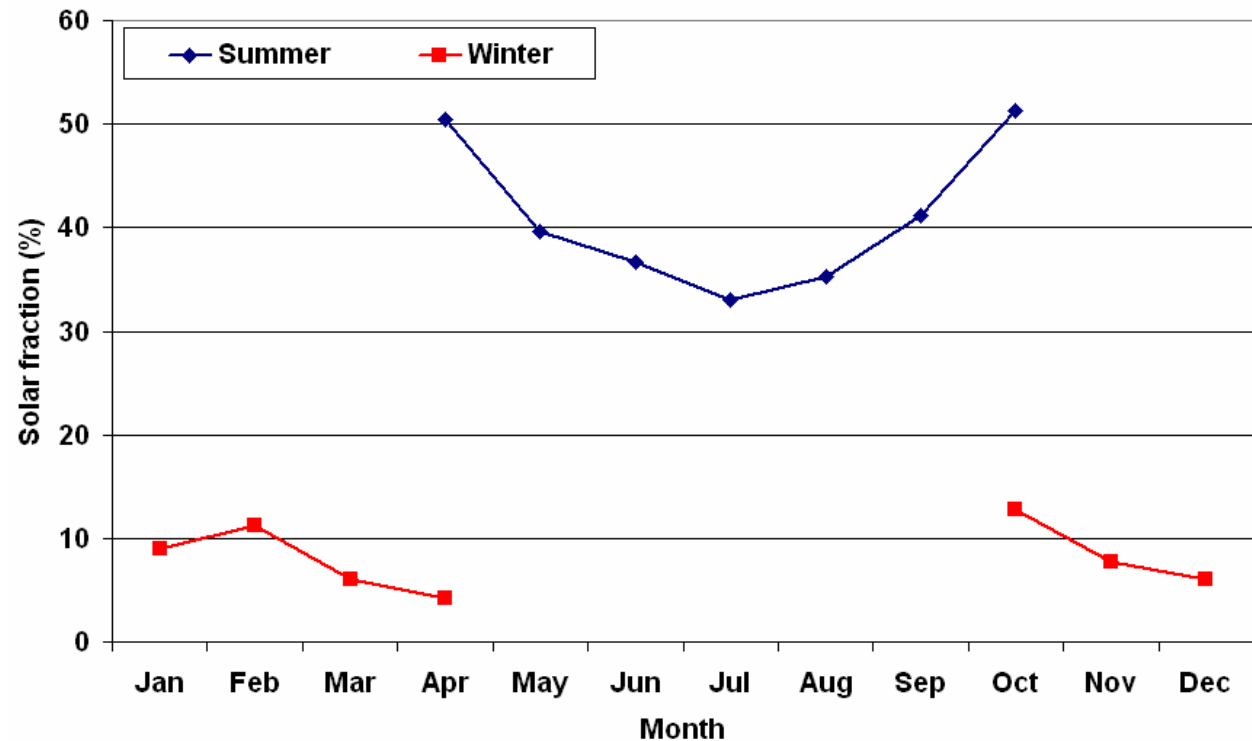

1. System design
2. System optimization

## 2. SYSTEM OPTIMIZATION

### Influence of the volume of the storage tank on the system performance

Case	Base case	Case 1
		Influence of the storage tank volume
Orientation	EW axis	<b>EW axis</b>
Insulation thickness of the solar collection loop	3"	<b>3"</b>
Volume of the storage tank	-	<b>From 1 to 5 m<sup>3</sup></b>
Insulation thickness of the storage tank	-	-
Solar ratio in summer (%)	37.8	<b>40.0 - 47.6</b>
Solar ratio in winter (%)	8.4	<b>18.6 - 20.9</b>

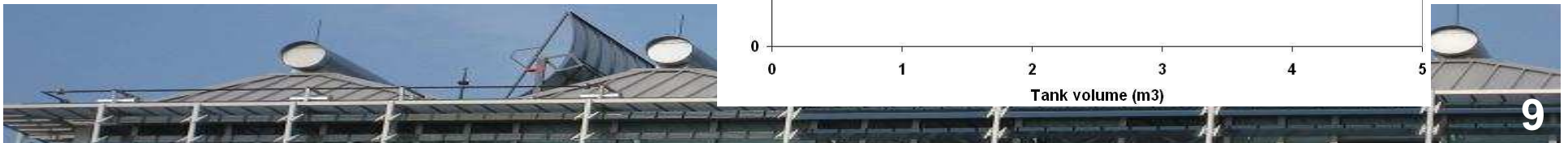
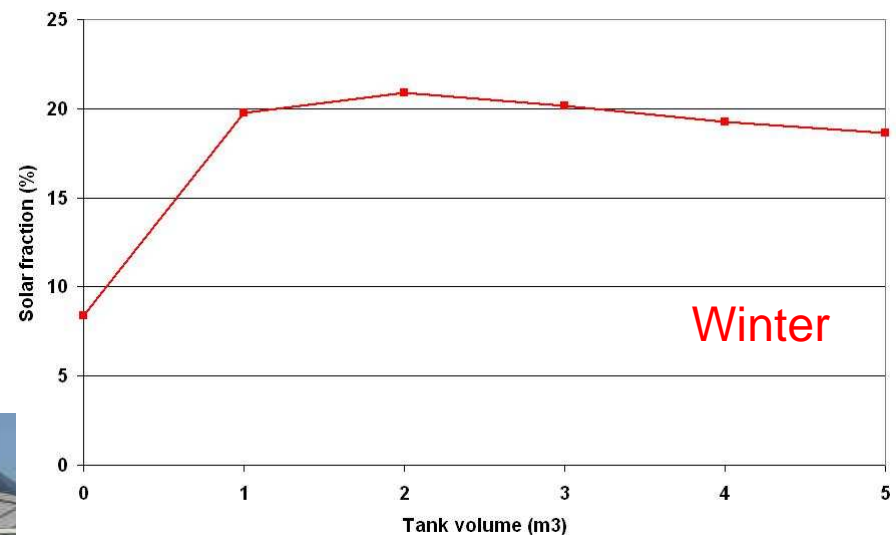
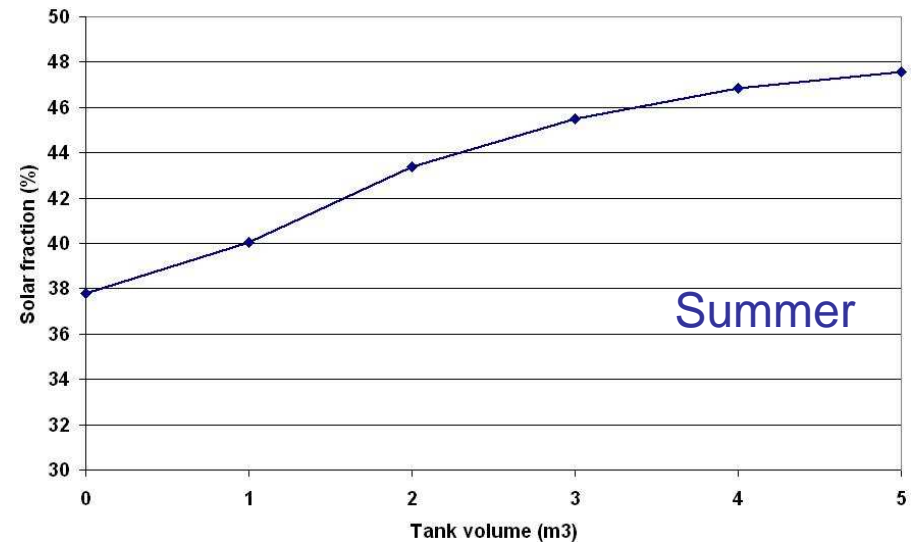

1. System design
2. System optimization

## 2. SYSTEM OPTIMIZATION

### Influence of the volume and insulation of the storage tank on the system performance

Case	Base case	Case 2
		Influence of the storage tank volume and insulation
Orientation	EW axis	<b>EW axis</b>
Insulation thickness of the solar collection loop	3"	<b>3"</b>
Volume of the storage tank	-	<b>From 1 to 5 m<sup>3</sup></b>
Insulation thickness of the storage tank	-	<b>From 0 to 4"</b>
Solar ratio in summer (%)	37.8	<b>40.0 – 49.2</b>
Solar ratio in winter (%)	8.4	<b>18.6 – 27.0</b>

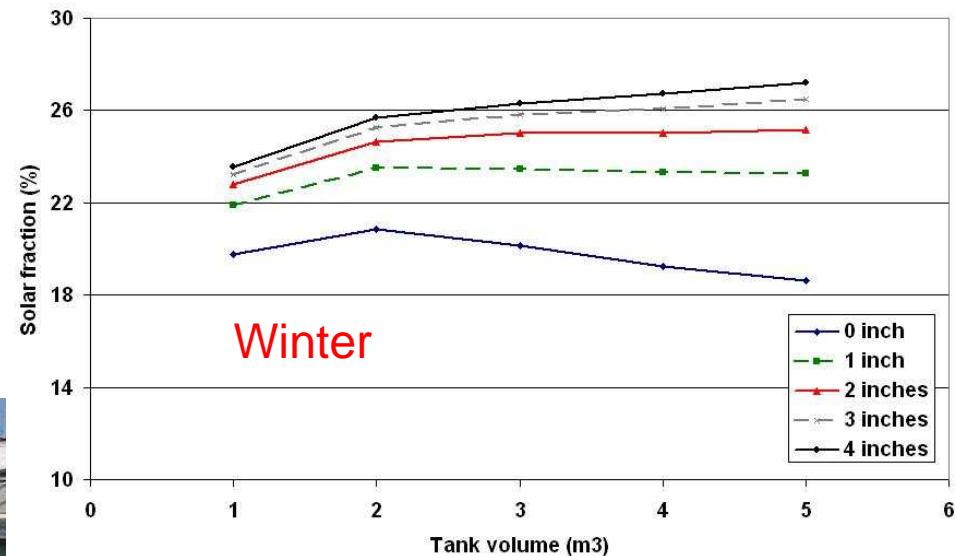
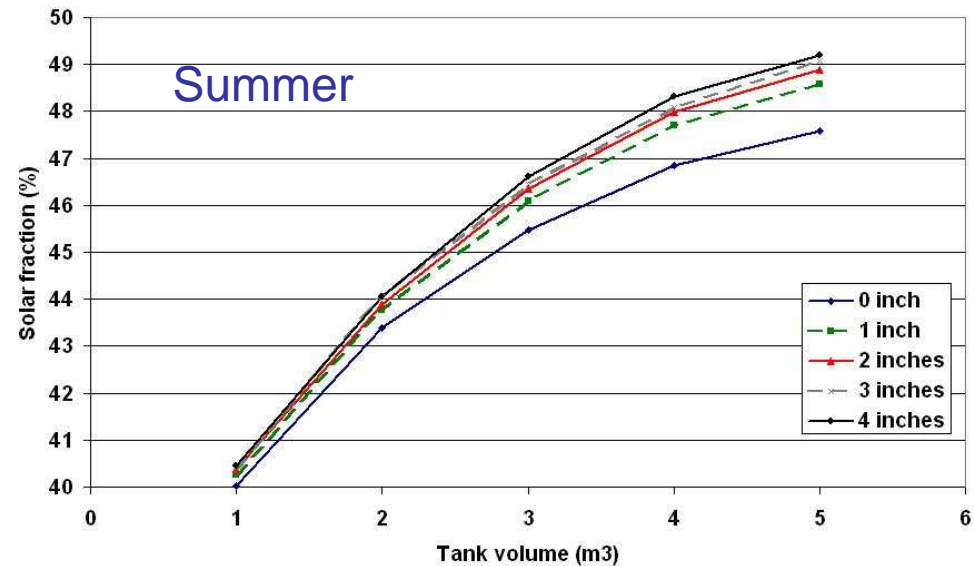

## CONCLUSION

---

- ▶ Existing system performance : Winter = 8.4% / Summer = 37.8%  
Can be improved up to 27% in winter and 49.2% in summer
- ▶ Creation of a tool to improve the design process based on given building heating and cooling demands
- ▶ The existing model can be extended to add characteristics of the heating and cooling supply systems and economical data to model the dynamic of the building and its supply systems and study the life cost savings of the solar thermal system



***QUESTIONS ?***



## Appendix - PREVIOUS MODEL : Description

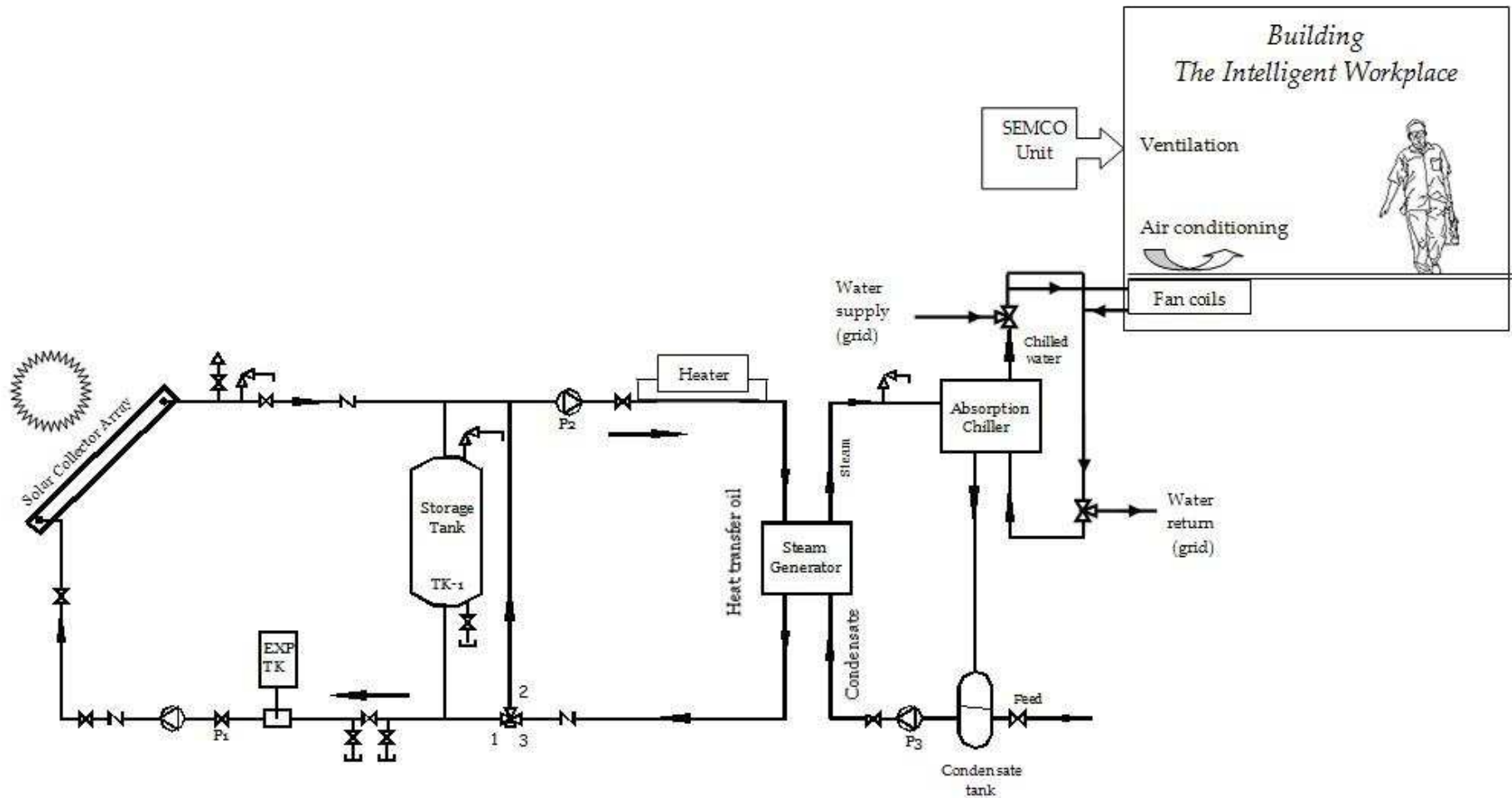

## Appendix - PREVIOUS MODEL : Description

---

### Assumptions :

- ▶ *Solar collector* : - evacuated tubes

$$\eta = 0.735 - 0.559 \Delta T/SR - 0.004 (\Delta T)^2/SR$$

$\Delta T$  :  $T_{fluid} - T_{amb}$  (°C)

$SR$  : instantaneous solar radiation ( $W/m^2$ )

- azimuth: -15° & slope: 25° (optimum)

- ▶ *HTF in solar collection loop* : Syltherm 800
- ▶ *Thermal storage* : hot fluid storage tank (in solar collection loop)
- ▶ *Absorption chiller* : double effect steam fired

### Sensitivity analysis

- ▶ *Design variables*

- Volume and insulation thickness of the storage tank

- ▶ *Operational variables*

- Operation of the solar pump (constant or variable speed)
- Maximum fluid temperature at the outlet of the solar collector



Performance modeling of the solar cooling system and optimization

**Solar ratio in summer (for 50m<sup>2</sup> solar array):**

-constant solar pump flow rate / variable operating temperature:

**from 38% to 57 % for a maximum operating temperature of 200°C  
(hot fluid storage tank from 1m<sup>3</sup> to 4.5 m<sup>3</sup>)**



## Appendix - Thermal losses coefficient of the piping

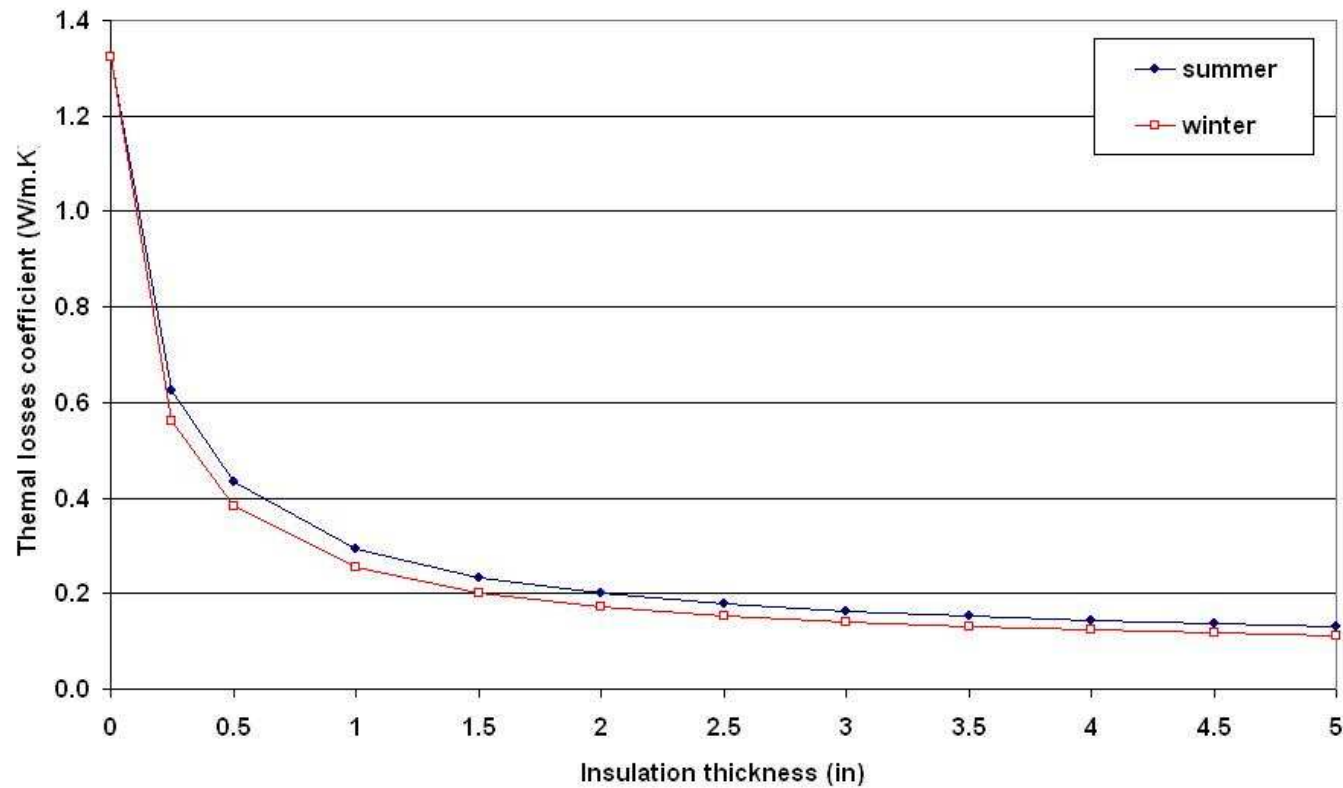

**Thermal losses coefficient in a 1" ¼ pipe for different insulation thicknesses  
(winter:  $k_{ins}=0.1260$  kJ/hr.m.K /summer:  $k_{ins}= 0.1476$  kJ/hr.m.K)**

