

Overall system performance modeling of the IWESS

Sophie Masson, Flore Marion, Elisabeth Aslanian
Center for Building Performance and Diagnostics (CBPD)

ABSIC Meeting - May 23rd 2007

Objectives

- Creation of an overall model to determine the energy performance and economic of the IWESS
 - Does the overall system meet the building load?
 - Is it effective (maintain comfort)?
 - What are its energy efficiency and its cost?
 - Does the system export energy to the grid?
- > Creation of models for each IWESS components : energy performance modeling in TRNSYS

3 on-going simulations

- 3 on-going simulations: performance study of 3 IWESS components:
 - Biodiesel engine generator with heat recovery
 - Fan coils
 - Natural ventilation
- Creation of models for each devices and systems : energy performance modeling in TRNSYS
 - to estimate annual performance
 - to assist / optimize the design: system configuration, equipment design, operation/control strategy

Biodiesel Engine Generator with Heat Recovery

Objectives

Performance Modeling of the of the Biodiesel Engine Generator with Heat Recovery for **two different operational strategies**:

- **DESIGN LOAD**: maximize the power output and recover as much waste energy to heat and cool the IW and regenerate the desiccant of the ventilation unit
- **LOAD FOLLOW**: meet the thermal heating, cooling, ventilation loads and see how much power we can generate

Biodiesel Engine Generator with Heat Recovery

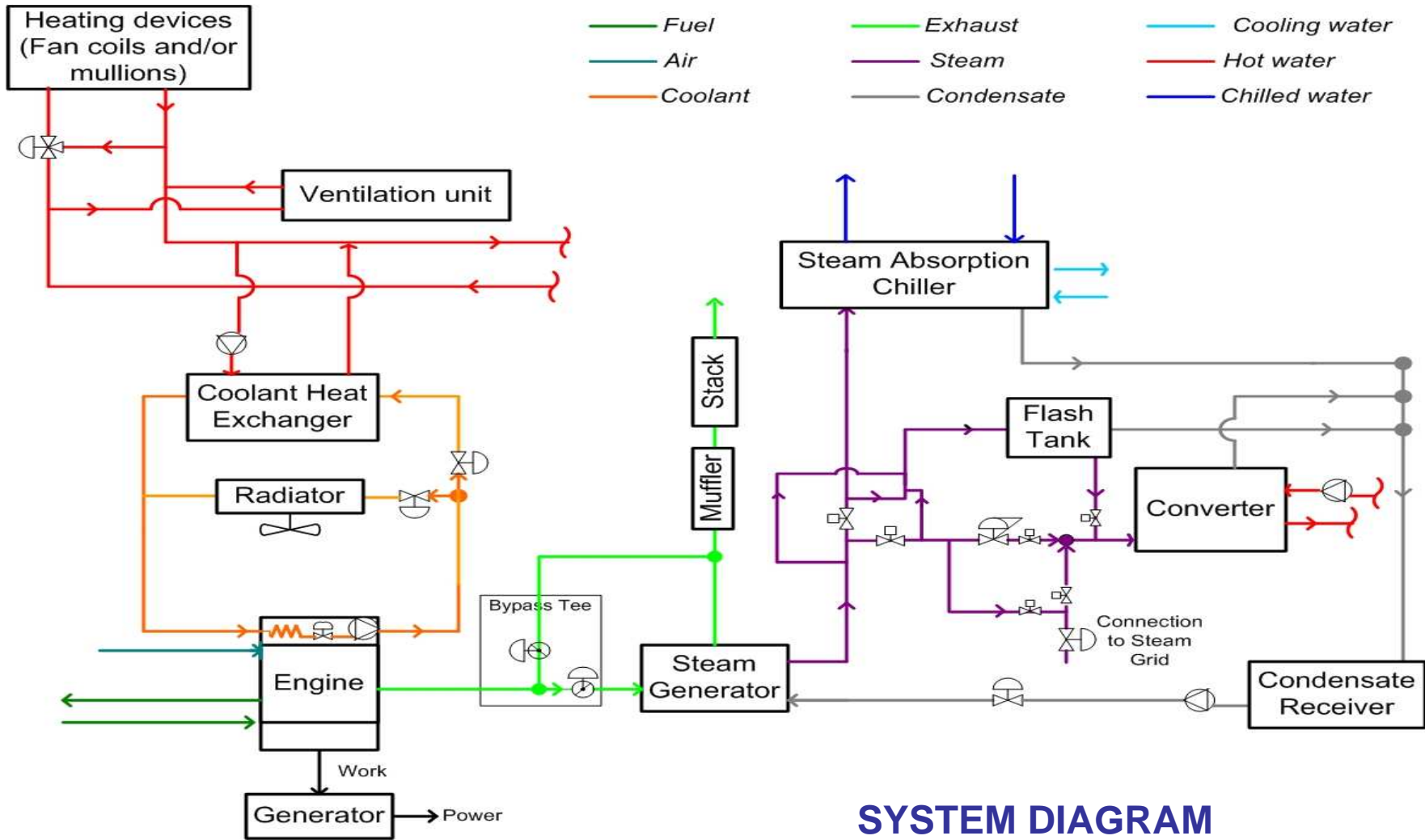

Biodiesel Engine Generator with Heat Recovery

Achievements

	Feb	Mar	Apr	May	Jun	Jul	Aug
Performance modeling of the biodiesel engine generator with heat recovery							
1. PRELIMINARY STUDY							
1.1 - Define of the objectives of the study							
1.2 - Study drawings							
1.3 - Study specification data							
1.4 - Write a report with an overall simple system diagram, specification data and description of the operation and controls							
2. TRNSYS SIMULATION							
2.1 - Preliminary work							
2.2 - Simulation "Design Load" (maximize the power output and recover as many waste energy as possible)							
2.3 - Simulation "Load follow" (meet the loads and generate power)							
2.4 - Study the overall results							
2.5 - Report							

ABSIC Meeting

Fan coils

Objectives

The purpose of this performance study is to determine:

- the ability of the fan coils to meet the IW_{south} office sensible loads
- the impact of fan coils' control strategy on energy consumption and thermal comfort (fan speed, water flow rate, water temperature, indoor setback and set point temperatures, unoccupied/occupied scenarios)
- the time response (time between the controller's signal is issued and when the temperature requirements are met, especially when switch between unoccupied and occupied period.)

Fan coils

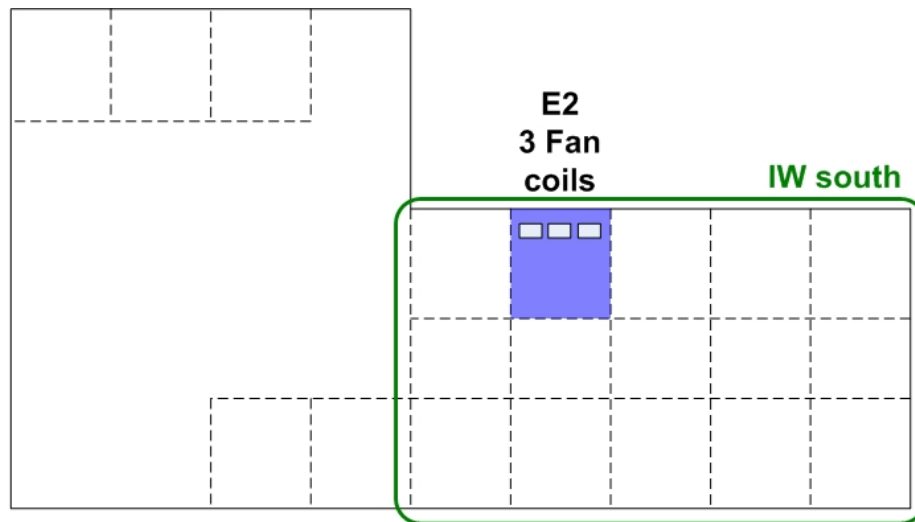

Assumptions

- Zone: E2
- Heating/Cooling: 3 LTG fan coils (VKB), non condensing operation with SIEMENS TEC controller
- Ventilation: Semco
- Occupancy: 3 people

Fan coils

Achievements: TRNSYS information flow diagram

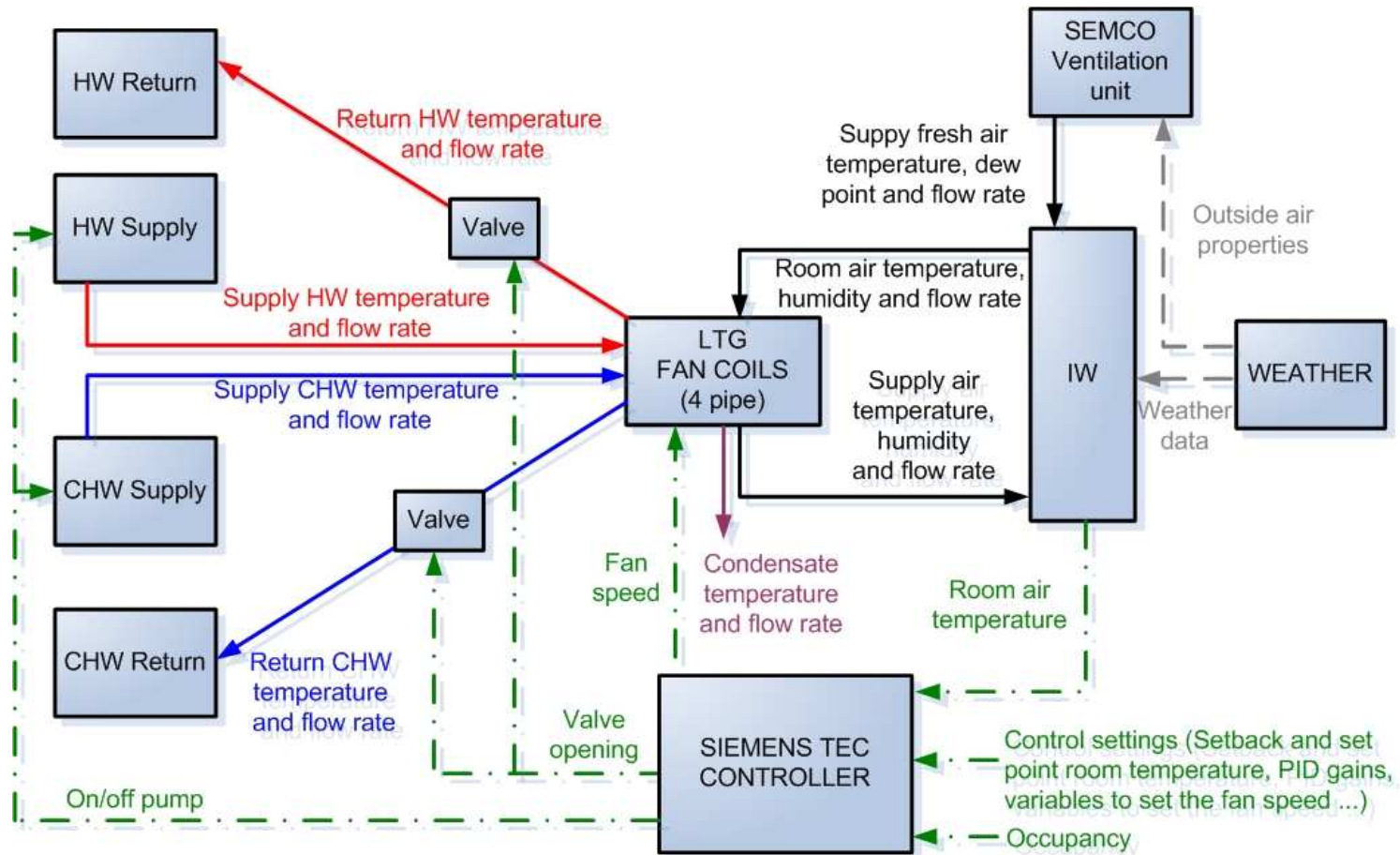

Fan coils

Achievements: TRNSYS MODEL

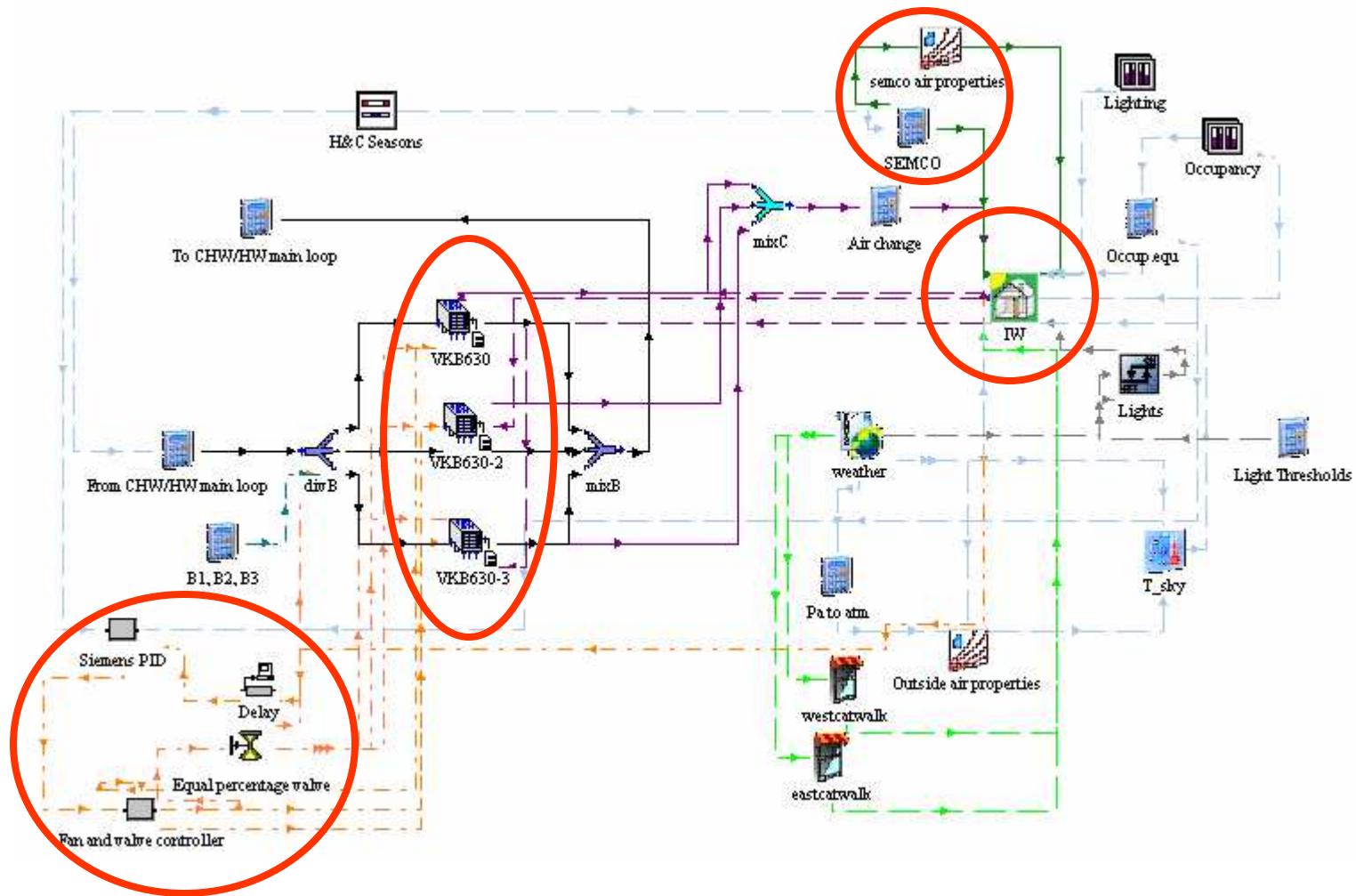

Fan coils

Results from the preliminary TRNSYS simulation (heating period)

- **Time response** (switch from unoccupied to occupied period):
 - 6-8 min to increase the air temperature of the zone from 17C to 21C (outside temperature :10C)
 - from 50 min to several hours to increase the operative temperature of the zone from 17C to 21C (based on the outside temperature)
- **Fan coil's operation:** Frequent variations in water and air flow rates
 - the fan speed and the valve opening are both determined based on the same PID loopout

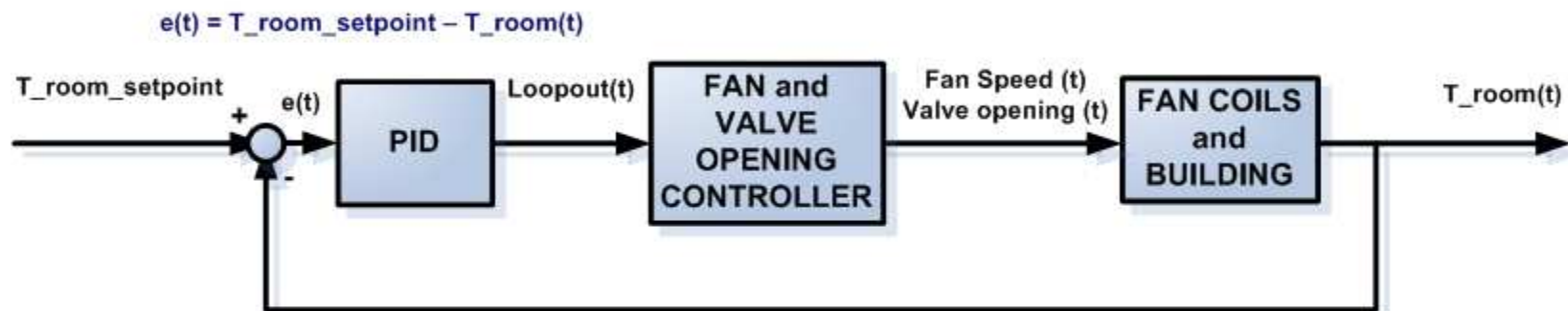

- the variable fan speed is staged, not continuous.

Fan coils

Achievements: SYSTEM STUDY

Other simulation model

-Matlab: Building (Lumped capacitance model), Semco and Fan coil (system and controls)

Next steps

- Validate all the simulation assumptions based on the LTG, SIEMENS PID and valve data
- Tune the PID parameters (PID gains, Fan low on, Fan med on, Fan hi on...)
- Study the system response for different occupancy profile, setback, setpoint temperature.

Natural ventilation

Objective: Update the existing TRNSYS / COMIS model

Existing TRNSYS / COMIS model

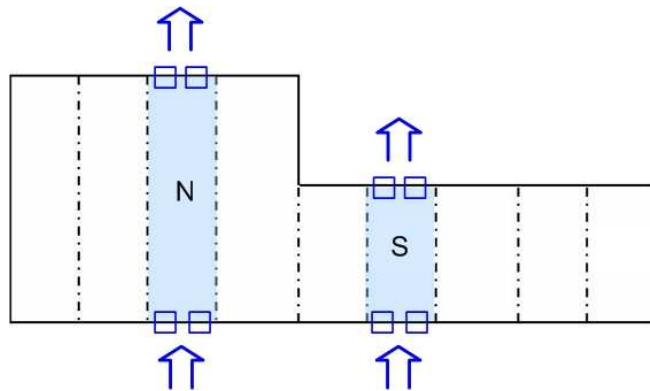

Zone :

- One bay (south or north) of IW (Pittsburgh, PA)
- 2 windows on each façade (E&W)

Natural ventilation:

- View window opening: two positions, maximum opening / close
- 4 windows opened at the same time

Mechanical systems:

- Fan coils and Semco

From April to October: 14% of energy savings (up to 60% during intermediate season) on ventilation and cooling loads (to maintain the thermal comfort during 84% of the occupied period) both in North and South bays : around 1,000 kWh per bay

Natural ventilation

Updated TRNSYS / COMIS model

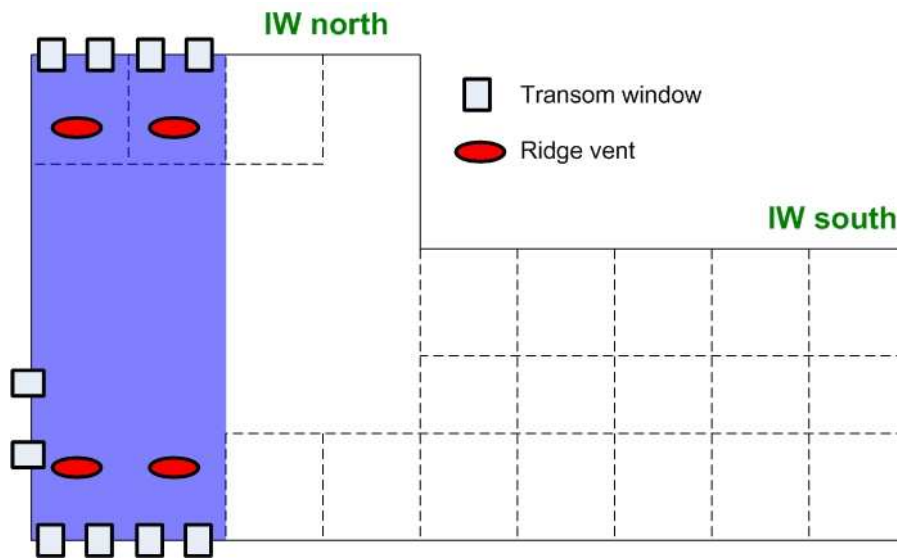

Zone :

- Two bay (north) of IW (Pittsburgh, PA)
- 4 windows on the west and east façades
- 2 windows on the north façade
- 4 ridge vents

Natural ventilation:

- Window (transom) opening: several positions
- 10 windows opened simultaneously
- 4 ridge vents open/closed

Mechanical systems:

- Fan coils and Semco (detailed model)

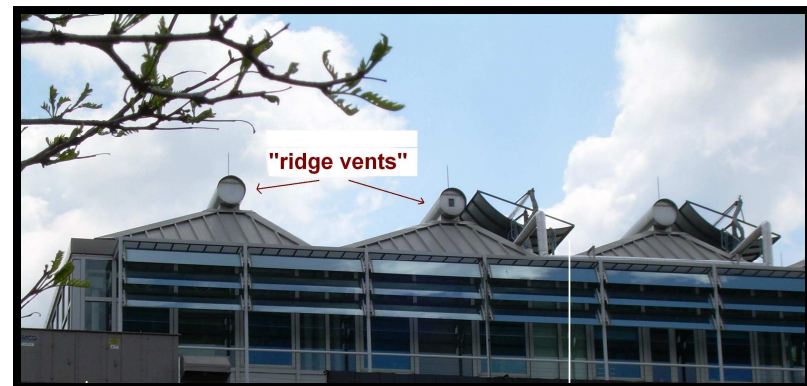

Natural ventilation

Objectives

- Assess the impact of the stack enhanced ventilation of ridge vents.
- Implement additional features to improve the existing controller: Control consideration of rain, wind speed, air change rate, window and vent opening (between 0 and 100%: open, partially open, close)
- Implement a detailed component model of the ventilation unit to simulate more accurately its energy consumption (electricity, gas for regenerating the desiccant).
- Exercise the model for different temperature control determinants and different simulation time step in order to assess the optimum control based on energy consumption and thermal comfort.